



**Jimma University
Jimma Institute of Technology
Faculty of Electrical & Computer Engineering
Graduate Program in Electrical Power Engineering**

**Voltage Profile Improvement and Power Loss Minimization of
Radial Distribution Feeders Using Optimal Allocation and Sizing of
Distribution Generator (DG). A Case Study on Jimma Old
Distribution Substation Agriculture Feeder.**

By:

Marta Zemedu Assefa

Advisors: Dr. Kinde Anley

Mr. Alebachew Tena (MSc.)

A Thesis Submitted to School of Graduate Studies of Jimma Institute of
Technology in Partial Fulfillment of the Requirements for the Degree of
Master of Science in Electrical Power Engineering

January 2019

Jimma, Ethiopia



**Jimma University
Jimma Institute of Technology
Faculty of Electrical & Computer Engineering
Graduate Program in Electrical Power Engineering**

**Voltage Profile Improvement and Power Loss Minimization of
Radial Distribution Feeders Using Optimal Allocation and Sizing of
Distribution Generator (DG). A Case Study on Jimma Old
Distribution Substation Agriculture Feeder.**

By:

Marta Zemedu Assefa

Advisors: Dr. Kinde Anley

Mr. Alebachew Tena (MSc.)

A Thesis Submitted to School of Graduate Studies of Jimma Institute of
Technology in Partial Fulfillment of the Requirements for the Degree of
Master of Science in Electrical Power Engineering

January 2019

Jimma, Ethiopia

ACKNOWLEDGMENT

In the beginning, I would like to give all honor and glory to the almighty God for allowing me to do and complete this work. Next, I would like to express my deep and sincere gratitude to my advisors, Dr. Kinde Anley and Mr. Alebachew Tena for their expert guidance, constructive comments, suggestions and encouragement without which this thesis work could have not been completed. I am very thankful as well, to my families as they have been a constant source of encouragement throughout study of this thesis.

Lastly but not least, I would like to thank staff members of the faculty and all peoples stood by my side during the execution period of the thesis work.

**Jimma University
Jimma Institute of Technology
Faculty of Electrical & Computer Engineering**

**Voltage Profile Improvement and Power Loss Minimization of
Radial Distribution Feeders Using Optimal Allocation and Sizing of
Distribution Generator (DG). A Case Study on Jimma Old
Distribution Substation Agriculture Feeder.**

By:

Marta Zemedu Assefa

Approval by Board of Examiners

_____	_____
Chair Person	Signature
<u>Dr. Kinde Anley</u>	_____
Thesis Advisor	Signature
<u>Mr. Alebachew Tena</u>	_____
Thesis Co-Advisor	Signature
_____	_____
External Examiner	Signature
_____	_____
Internal Examiner	Signature

DECLARATION

I, the undersigned, declare that this thesis is my original work, has not been presented for a degree in this or any other universities, and all sources of materials used for the thesis have been fully acknowledged.

Marta Zemedu
Name

Signature

Date of Submission: -----

This thesis has been submitted for examination with my approval as a university academic advisor.

Dr. Kinde Anley
Thesis advisor

Signature

Mr. Alebachew Tena
Thesis Co-advisor

Signature

ABSTRACT

Electric power distribution systems with radial nature and improper installation of successive feeders' causes voltage drop. In addition, the growth of load demand increases the current drawn from the source and hence voltage drop and power loss will also be increase. Different methods used to avoid such problems; one of these methods is using a distributed generation (DG). In this thesis minimization of power loss and voltage profile improvement in radial distribution system have been achieved by using an optimal type, size and location of DG. IEEE 33 bus system is used for comparing analytical and particle swarm optimization with loss sensitivity factor analysis methods with three load variation cases, and the best method is selected to be applied for optimization of DG units in agriculture feeder of Jimma city. Load flow analysis of the test system and existing feeder is performed with forward backward sweep method. When comparing the results obtained by the two methods, the particle swarm optimization (PSO) method with loss sensitivity factor analysis in type-1 DG provides an optimal size and location of DG with best loss minimization and improved voltage profile result than analytical method. In case of full load condition, the optimal locations of DG found to be bus 13 and 30 with optimal size of 773.4KW and 632.4 KW by PSO method with percentage reduction for total real and reactive power loss obtained as 52.73% and 52.56% respectively. The voltage magnitudes in all buses are within acceptable limit and the minimum per unit voltage is 0.9521 at bus 33. Furthermore, the impact of DG and the selected method have been analyzed and verified by considering case study at Jimma old substation. Among the five 15 KV feeders of the substation, Agriculture feeder is considered and the total real and reactive power loss before optimization was 94KW and 53KVAR, then using PSO and loss sensitivity factor the optimal location of bus 26 and 40 with optimal size of 782 KW and 474 KW of DG is obtained. The percentage reduction of loss found to be 43.6% and 42.8% in real and reactive power loss respectively with good voltage profile improvement. Finally, Economic analysis using HOMER PRO software also results in optimal combinations of technologies depending on net present cost (NPC) of the system for the selected feeder. Economic issues associated with the DG unit installation: such as cost of energy losses (CL) with and without DG unit have been compared and total saving of 32,324.4 \$ is found.

Keywords: *Distributed Generation (DG) units, loss sensitivity factor analysis (LSF), Particle Swarm Optimization (PSO), Optimal Size, HOMER, NPC, IEEE.*

TABLE OF CONTENTS

ACKNOWLEDGMENT.....	i
DECLARATION	iii
ABSTRACT.....	iv
LIST OF FIGURES	viii
LIST OF TABLES	ix
LIST OF ABBREVIATIONS.....	x
LIST OF SYMBOLS	xii
CHAPTER ONE	1
1. INTRODUCTION	1
1.1. Background	1
1.2. Problem Statement	2
1.3. Objectives of the thesis	3
1.3.1. General objective	3
1.3.2. Specific Objectives	3
1.4. Scope of the thesis	3
1.5. Significance of the thesis	4
1.6. Methodology and materials used	4
1.7. Outline of the thesis	5
CHAPTER TWO	6
2. LITERATURE REVIEW	6
CHAPTER THREE	10
3. THEORETICAL BACKGROUND OF THE THESIS.....	10
3.1. Radial distribution system.....	10
3.2. Distributed Generation.....	11
3.2.1. Distributed Generation Technology.....	12
3.2.2. Optimal sizing and allocation of distribution generator.....	13
3.3. Power flow analysis of radial distribution system	14
3.3.1. Backward/Forward Sweep Method.....	15
3.4. Particle swarm optimization.....	16
3.4.1. Basic Particle Swarm Optimization Algorithm.....	17

Voltage Profile Improvement and Power Loss Minimization of Radial Distribution Feeders Using Optimal Allocation and Sizing of Distribution Generator (DG)

3.4.2. PSO Algorithm Parameters	20
3.4.3. Advantage and disadvantages of PSO algorithm	22
CHAPTER FOUR.....	23
4. PROPOSED METHODOLOGY AND MODELING	23
4.1. Mathematical modeling of Load flow analysis using backward/forward sweep method	23
4.1.1. Per unit calculation.....	23
4.1.2. Algorithm for forward backward sweep load flow	26
4.1.3. Procedure Forming BIBC and BCBV Matrix	28
4.1.4. Flow chart for Forward Backward Sweep method	29
4.1.5. Power flow analysis using FBS method by considering DG units	29
4.2. Optimal sizing and allocation of DG using analytical method	30
4.2.1. Procedures for analytical method for optimal allocation and sizing	33
4.3. Optimal sizing and allocation of DG using particle swarm optimization	34
4.3.1. Optimal allocation of DG.....	34
4.3.2. PSO Implementation Steps	34
4.3.3. Flow chart of PSO algorithm for optimal sizing of DG	36
4.4. Optimization of DG using HOMER software.....	37
CHAPTER FIVE	38
5. RESULTS AND DISCUSSION	38
5.1. Test system.....	38
5.2. Simulation result on load flow analysis using FBS method without DG.....	39
5.3. Result on optimal allocation and sizing of DG using analytical method	41
5.4. Result on optimal allocation and sizing of DG using loss sensitivity factor and PSO method.....	45
5.5. Case Study and Data Analysis	48
5.5.1. Description of the study area	48
5.5.2. Jimma Distribution Substation.....	48
5.5.3. Radial Distribution of the selected Feeder	50
5.6. Economic analysis for optimal size of DG Units.....	54
5.6.1. Optimization result using HOMER software	54
5.6.2. Economic analysis using cost of energy losses (CL)	55
CHAPTER SIX.....	56
6. CONCLUSION AND RECOMMENDATION	56

Voltage Profile Improvement and Power Loss Minimization of Radial Distribution Feeders Using Optimal Allocation and Sizing of Distribution Generator (DG)

6.1. Conclusion	56
6.2. Recommendation	57
REFERENCES	58
APPENDIX A.....	60
APPENDIX B	62
APPENDIX C	63
APPENDIX D.....	64

LIST OF FIGURES

Figure3. 1 Example for typical radial system [14]	10
Figure4. 1 Electrical equivalent of a typical one branch	23
Figure4. 2 Single line diagram of 5-nodes radial distribution feeder [26].....	26
Figure4. 3 Flow chart for forward/backward load flow analysis.....	29
Figure4. 4 Flow chart for PSO in optimal sizing of DG.....	36
Figure5. 1 Single line diagram for IEEE 33 bus system.....	38
Figure5. 2 Voltage profiles at the three conditions of load before DG.....	40
Figure5. 3 Real and reactive power loss minimization at full load case by analytical method	42
Figure5. 4 Voltage before and after placement of DG at full load case by analytical method.....	42
Figure5. 5 Voltage profile improvement at 50% of full load condition by analytical method.....	43
Figure5. 6 Voltage profile improvement in 150%full load condition by analytical method	44
Figure5. 7 Voltage profile improvement at full load condition	45
Figure5. 8 voltage profile improvement at 50%full load case by a PSO method.....	46
Figure5. 9 Voltage profile improvement at 150%full load case using PSO method.....	47
Figure5. 10 Map of Jimma city.....	48
Figure5. 11 Partial view for Jimma substation	49
Figure5. 12 Single line diagrams of 40 buses of agriculture feeder	50
Figure5. 13 Voltage profile improvement for agriculture feeder.	53
Figure5. 14 Schematic diagram of the system design.....	54

LIST OF TABLES

Table 5. 1 Voltage profile for three cases of load variation.....	39
Table 5. 2 Real and reactive power loss at three load conditions	40
Table 5. 3 Summary result for analytical method.....	44
Table 5. 4 Summary of result for PSO method.....	47
Table 5. 5 Line and load data of agriculture feeder	51
Table 5. 6 Result summary of agriculture feeder.....	53
Table 5. 7 HOMER optimization result.....	54

LIST OF ABBREVIATIONS

ACO.....	Ant colony optimization
AFSA.....	Artificial fish swarm algorithm
AVR.....	Automatic voltage regulator
BCBV.....	Branch current to bus voltage
BIBC.....	Bus injected branch current
CL.....	Cost of energy losses
COE.....	Cost of energy
DG.....	Distributed generation
EEP.....	Ethiopian Electric Power
ELF.....	Exhaustive load flow
FA.....	Firefly algorithm
GA.....	Genetic Algorithm
FBS.....	Forward backward sweep
GHI.....	Global horizontal Irradiance
HOMER.....	Hybrid optimization for electric renewables
IA.....	Improved Analytical
IEA.....	International energy agency
IEEE.....	Institute of electrical electronic engineers
KCL.....	Kirchhoff's current law
KVA.....	Kilo volt ampere
KVL.....	Kirchhoff's voltage law
LMP.....	Locational marginal price
LSF.....	Loss sensitivity factor
MVA.....	Mega volt ampere
NASA.....	National aeronautics and space administration
NPC.....	Net present cost
NREL.....	National renewable energy laboratory
OPF.....	Optimal power flow
PSAT.....	Power system analysis toolbox.
PSO.....	Particle swarm optimization

Voltage Profile Improvement and Power Loss Minimization of Radial Distribution Feeders Using Optimal Allocation and Sizing of Distribution Generator (DG)

PV.....Photo voltaic
PWS.....Power world simulator
RES.....Renewable energy sources
SCADA.....Supervisory control and data acquisition system
SRMC.....Short run marginal cost
STP.....Standard room temperature and pressure
TNPC.....Total net present cost

LIST OF SYMBOLS

α	Loss coefficient
β	Loss coefficient
δ	angle
C	Acceleration Coefficient
I	Current
r	resistance
V	Voltage
x	Reactance
z	Impedance
R/X	Resistance to reactance ratio
P	Active power
Q	Reactive power
Ω	Ohm
ω	Inertia weight

CHAPTER ONE

1. INTRODUCTION

1.1. Background

Electrical power Supply scheme is divided into three major units, namely, generation, transmission, distribution and utilization. In existing high transmission and distribution networks from power plants to load centers, there is greater power loss which is considered as technical and non-technical losses. So far, different professional efforts are deployed to reduce these losses; such as network shortening, re-conducting, insertion of the substation, capacitor installation, automatic voltage regulator (AVR), replacement of connectors and so on [1]. But to support the techniques above and to alleviate the challenge behind the power system losses, recently distributed generations began to be exploited globally for support the electricity needs of countries like Ethiopia.

Distributed generation system refers to electric generation resources which are located throughout the electrical distribution grid usually owned by customers, often smaller in scale, and typically powered by renewable energy sources (such as wind, solar, or biomass). Distributed generation is different from centralized, utility-owned generation sources like traditional power plants fueled by coal, natural gas, nuclear power or utility-scale solar or wind farms. The continuous worldwide integration of distributed generation (DG) units in the electric power systems is a result of increased energy demand, electricity markets' privatization, and environmental protection from emissions and of technological progression [2]. A properly designed and operated power system should meet the continuously changing load demand for active & reactive power, should supply energy at minimum cost & with minimum ecological impact and the quality of power supply must meet certain minimum standards (i.e., level of reliability, a constancy of frequency and voltage). Having integrated DG as a backup source, it ensures the overall security of the system by supporting and improving the system's voltage profile. The centralized generation remains the primary source of electricity, while the DG along with storage technologies such as batteries provide reliability and resilience to the power system. Besides, the DG can also be used as a stand-alone and backup to supply power to the customers that are not connected to the grid, and that cannot tolerate service interruption like hospitals respectively.

While having different network configurations like a radial, ring main & interconnected systems, the radially networked power systems are designed for unidirectional power flow application. So, in line with this, installation of DG units probably influences the power flow and voltage conditions and might increase the complication of the system. On the other hand, DG is supposed to support and improve the system's voltage, but the question that is raised is up to what extent is this statement accurate, since it has been demonstrated that the penetration of DGs in the distribution system may cause over or under voltage and can have positive or negative influences on the network.

Furthermore, specific DG technologies vary their output power level over time, as in the case of photovoltaic and wind generators. Therefore, voltage fluctuations occur which in turn deteriorates the power quality delivered to consumers. Moreover, overvoltage and under voltage in distribution networks with DG have been introduced due to the incompatibility of DGs with the existing voltage regulation methods. In general, the distribution networks are regulated with the help of voltage regulators, capacitors, and the tap changing of transformers. For example, voltage regulator confuses if DG is attached downstream by setting a voltage lower than the required value. So, careful coordination between the DG and voltage regulator is essential [4, 8].

With the growing use of DG, it is critical to study its impacts on the distribution system operation with proper planning. The planning of the electric system comprises several factors: types of DG, capacity, and number of the DG units and the installation location, etc. Therefore, optimal sizing & placement of DG reduce the system losses, improve the voltage profile within the acceptable limits, increase the reliability, and increase overall performance and efficiency of the distribution network.

1.2. Problem Statement

In Ethiopia, the energy demand is expected to be growing much more due to population growth, social and economic developments. The increased load demand in distribution systems, increase current drawn from the source and hence, voltage drop & power loss will also increase. Besides, the radial nature of the Ethiopian distribution system and improper installation of successive feeders causes voltage drop from source buses to load buses. In Jimma old substation feeders the secondary distribution transformers are not properly allocated in account of the load centers.

Besides, whenever there is expansion of the load, simply cables are tapped to the transformers irregularly and hence over loading and heating is resulted which in turn causes unnecessary power losses. The increased loss in the distribution system will also result in low voltage profile at the connection end of the load. Therefore, a method must be devised for minimizing real power losses and improve voltage profiles. So far different classical methods have been applied to minimize power loss and improve the voltage profile but could not be found as promising approach to solve these problems. Recently emerging technologies of distributed generation (DG) systems are proposed as a solution. But the penetration of DGs in the distribution system with non-optimized size and location may increase the loss and cause over or under voltage and can have positive or negative influences on the system. So, to minimize the negative impacts and enhance positive influences of DGs, novel methods like analytical and particle swarm optimization with loss sensitivity factor methods have been used to find the optimal size, location and type of DG.

1.3. Objectives of the thesis

1.3.1. General objective

The general objective of this thesis is to improve voltage profile and minimize power loss of radial distribution feeders using optimal allocation, sizing & type of DG.

1.3.2. Specific Objectives

The specific objective of this thesis includes;

- Performing load flow analysis using forward backward sweep method to determine voltage and power loss level of each bus bar in the system.
- Identify the optimal size of selected distributed generation.
- Identify the optimal location of selected distributed generation.
- Determine economic issues associated with the DG unit installation, such as using HOMER PRO and cost of energy losses (CL).

1.4. Scope of the thesis

The study in general focuses on voltage profile improvement & power loss reduction of distribution feeders by using optimization techniques. This thesis work mainly includes:

Voltage Profile Improvement and Power Loss Minimization of Radial Distribution Feeders Using Optimal Allocation and Sizing of Distribution Generator (DG)

- Power flow analysis of IEEE 33 bus system and agriculture feeder
- Optimal allocation and sizing of DG unit.
- Identification of best type of DGs.
- Optimal and best design system determination from all possible combinations by using HOMER Pro.
- IEEE standard 33 bus system is used for analysis of the system to decide the best method to be used for optimization of agriculture feeder in Jimma distribution system under case study.

1.5. Significance of the thesis

With optimal sizing & allocation of DG in radial distribution system the following significances are obtained,

- Voltage profile improvement in low voltage feeder
- Power loss minimization
- Can be used as spinning reserve
- Improve the power quality of the distribution network with avoidance of voltage sag and swell to permissible limit of ± 0.05 pu.

1.6. Methodology and materials used

For the sake of addressing the aforementioned objectives, different methodologies/procedures have been followed, mentioned as follows:

- Literature Review: Different journals, publications and other references which are related to voltage profile improvement and real power loss minimization with optimal placement and sizing of distributed generation have been reviewed.
- Problem formulation: Location and size of DG units is decided in such way that with the objective of Minimize sum of real power losses and minimize sum of voltage deviations.
- Design / Modeling: The modeling of one line diagram representation of distribution system of agriculture feeder based on IEEE 33-bus radial distribution feeders is performed with base line reference values and design parameters.
- Power flow analysis: backward forward sweep power flow analysis is carried out for both selected test system due to high ratio of R/X in the radial distribution network.

- The solution methodology has two parts:
 - First analytical method for optimal allocation and sizing of different types of DG unit is used and by using exact loss formula in IEEE 33-bus radial distribution system.
 - Secondly, for optimal allocation of the DG sensitivity methods used and for sizing of units PSO algorithm has been deployed also in IEEE 33-bus radial distribution system.
 - Thirdly, by comparing the above two methods, the method with best result is used for case study in agriculture feeder.
- Analysis of the result: the loss reduction, the voltage profile improvement & the system capacity released are computed.
- Annual cost of energy loss and cost characteristics of DG is determined using appropriate formulas and optimization of the system is verified by using HOMER software.
- Comparative Evaluation & verification of the result with & without DG units have been examined.

1.7. Outline of the thesis

This thesis work consists of a total of six chapters. Chapter one is general introduction of the thesis, which highlights the basic idea and gives an insight or a direction to the body of the thesis. Chapter two reviews literatures of previous works which are related to optimal placement and sizing of distributed generation using analytical method and PSO algorithm. In the third chapter the general overview about radial distribution system, distributed generation, forward backward sweep load flow analysis and particle swarm optimization has been presented. In chapter four the methodology of the thesis by mathematical formulation and flow charts has been discussed. Chapter five discusses about results on FBS load flow method and the optimal size and allocation of DG with analytical and PSO algorithm has been presented for IEEE 33-bus radial distribution system and after deciding which one best method it is applied for agriculture feeder. Chapter six presents conclusion and recommendations.

CHAPTER TWO

2. LITERATURE REVIEW

Researchers tried to identify various techniques for optimal allocation and sizing of DGs, for enhancing the voltage profile & loss minimization of utility network systems. Some reviews of research outputs provided by different authors are mentioned below.

V. Vita (2017), presents a decision-making algorithm that has been developed for optimal sizing & allocation of distributed generation (DG) units in weak distribution networks. IEEE 33-bus radial distribution system modeled using NEPLAN 360 software, has been used for testing the proposed algorithm. Besides, extended Newton-Raphson method is performed to the examined distribution system without connecting any DG to the network for computing the load flow. After load flow analysis buses arranged in decreasing order of the voltage deviation, and then the DG is connected to the buses which violate the lower limit of voltage deviation. Two different types of DGs (photovoltaic and wind generator) with different size in total seven DGs are used. It is found that seventeen buses have violated the lower limit of 95%. Each one of the seven DG units has been connected to the seventeen buses and load flow analyses are computed by calculating the network's voltage profiles and power losses (real and reactive). Totally, one hundred and nineteen load flow analysis iterations are conducted. Even though the proposed algorithm working well with acceptable accuracy it is not clear how the number and capacity of DGs decided and it needs more time in order to perform this much of power flow analysis.

A. Marneni et al. (2015), analyze a practical rural feeder of 3.06 MW peak load in Mysuru, Karnataka, India. The Saraswathi feeder is designed in power world simulator (PWS) as per the balanced single line diagram. After designing and necessary parameters determination, the simulation results are examined and verified with the help of voltage profile and system losses magnitudes with and without DG. In addition, hybrid Optimization of Multiple Electric Renewables (HOMER) optimization analysis designs best system model by considering different constraints and with Renewable Energy sources (RES) for the rural distribution feeder. Based on giving inputs for each Component (cost input, sensitivity variables, size of each component), HOMER Optimization analysis designs better system by considering all system constraints.

In the research the detailed method for power flow analysis in PWS and how such size of DG is selected are not well addressed.

S. Essallah et al (2018), presents a DG placement and sizing method regarding system losses reduction, voltage magnitude and stability enhancement. Three DG allocation approaches founded on voltage magnitude enhancement and power loss minimization. The system weakest buses were selected for DG allocation in the basis of sensitivity methods and optimal DG size of a single DG unit has been determined by means of the quadratic curve-fitting technique. Multiple DG units' placement has been performed using loss improvement and loss reduction indices. Proposed approach has been applied to the 33- bus distribution system. The load flow method is not clear and the sizing of DG is more time taking,

Zonkoly, (2011) used PSO technique to find the best solution of the multi-objective problem of placing and sizing of distributed generation (DG) units in distribution network with non-unity power factor considering different types of load models. The proposed multi-objective function to be optimized includes a wide range of technical issues such as active and reactive power losses of the system, the voltage profile, the line loading, the MVA intake by the grid and a short-circuit-level parameter to represent the protective device requirements. The results indicate that the analysis of continuation power flow to determine the effect of DG units on the most sensitive buses to voltage collapse has been carried out. The proposed algorithm has been tested using the 38-bus radial system and the IEEE 30-bus meshed system. The results showed that the proposed algorithm is capable of optimal and fast placement of DG units. The results clarified the efficiency of this algorithm for improvement of voltage profile, reduction of power losses.

Wang and Nehrir (2004) proposes analytical methods to define the DG optimal placement with unity power factor in radial as well as networked systems to minimize the power loss. Placement of DG in a radial feeder is analyzed & obtained for different types of loads and DG sources. Method is presented to find the optimal bus for placing DG in a networked system based on bus admittance matrix, generation information and load distribution of the system. The proposed methods are tested by simulation on radial feeders using IEEE 6-bus & IEEE 30-bus test system, and a subset of it. Simulation results verify the proposed analytical approaches.

Voltage Profile Improvement and Power Loss Minimization of Radial Distribution Feeders Using Optimal Allocation and Sizing of Distribution Generator (DG)

Hung et al. (2011) used improved analytical (IA) method to optimally size all DG types (synchronous machines, inverter-connected DG and induction generators) to find the optimal operating DG power factor based on real and reactive power loss minimization. The authors compare the IA's performance to the exhaustive load flow (ELF) method that enumerates all optimal size and location combinations. The IA method approximated the DG sizing first with the IA formulas then enumerated the optimal DG locations according to the actual minimum losses obtained by the DG size obtained by a load flow run. The authors also compared results from the IA and ELF methods to the loss sensitivity factor (LSF) method. Their results show that the IA achieved a loss reduction of 61.62% which was slightly worse than the ELF at 64.83%. The LSF yielded the worst performing loss reduction at 59.72%. Results were consistent for three IEEE test systems (16, 33 and 69 bus).

Gautam and Mithulanathan (2006) proposes two new methodologies for optimal placement of distributed generation (DG) in an optimal power flow (OPF) based wholesale electricity market. The candidate locations for DG placement have been identified on the basis of locational marginal price (LMP). Obtained as lagrangian multiplier associated with active power flow equation for each node, LMP gives the short run marginal cost (SRMC) of electricity. Consumer payment has been evaluated as a product of LMP and load at each load bus, is proposed as another ranking to identify candidate nodes for DG placement. The proposed rankings bridges engineering aspects of system operation and economic aspects of market operation and act as good indicators for the placement of DG, especially in a market environment. In order to provide a scenario of variety of DGs available in the market, several cost characteristics have been assumed. For each DG cost characteristic, an optimal placement and size has been identified for each of the objectives. The proposed methodology has been tested in a modified IEEE 14 bus test system.

Kalantari and Kazemi (2011) presented GA based optimal placement of DG units and proper allocation of shunt capacitors in order to decrease loss reduction and improvement of voltage profile in distribution systems. The objective function has three important indices (active and reactive power losses and voltage profile). The power flow has been done using backward forward sweep method and simulation has been carried out on a 28-bus test system. The placement of DGs and capacitors has been done simultaneously in the test system.

Voltage Profile Improvement and Power Loss Minimization of Radial Distribution Feeders Using Optimal Allocation and Sizing of Distribution Generator (DG)

The proposed method yielded a significant reduction of losses and improvement of voltage profile with presence of DG unit and capacitors. The results can be more realistic if load models are voltage and frequency dependent.

M. Damodar Reddy & V. C. Veera Reddy (2008) have applied fuzzy and particle swarm optimization for optimal capacitor placement on the primary feeders of the radial distribution network with the objective of power loss reduction and voltage profile improvement. Fuzzy algorithm is used as method of selecting the optimal location and to determine the optimal size of the capacitor PSO is used. The proposed method is tested on 15-bus, 34-bus and 69-bus test systems.

In order to alleviate the gaps observed in the aforementioned reviews, this thesis work proposes backward forward sweep load flow analysis with comparison on the results of analytical and particle swarm optimization method to find the size of DG and optimal allocation of DG in 33 bus radial distribution system for using the best method for case study in agriculture feeder using MATLAB software. The optimization of the system also analyzed economic issues using HOMER PRO by considering different constraints.

CHAPTER THREE

3. THEORETICAL BACKGROUND OF THE THESIS

3.1. Radial distribution system

The distribution system is a connection between the bulk power system and customers. According to the scheme of operation, distribution systems can be classified into three types such as radial, ring main and interconnected system. In many cases, Distribution systems are designed to operate in a radial configuration, since the radial system is simple as fed at only one end and has a low initial cost. It is also beneficial when the generation station is located at the center of the load. In this type of configuration, feeders on the primary level receive power from distribution substation to the load areas with the help of sub feeders and lateral-branch circuits. Besides, the terminal of the distributor which is nearest to the feeding point is heavily loaded as the consumers are connected at this termination. Accordingly, the consumers are dependent on a single feeder and single distributor. Hence, any Fault on the feeder or distributor cut off the supply to consumers who are on the side of the fault. The consumers at the distant end of the distributor would be subjected to high voltage fluctuations when the load on the distributor continuously changed.

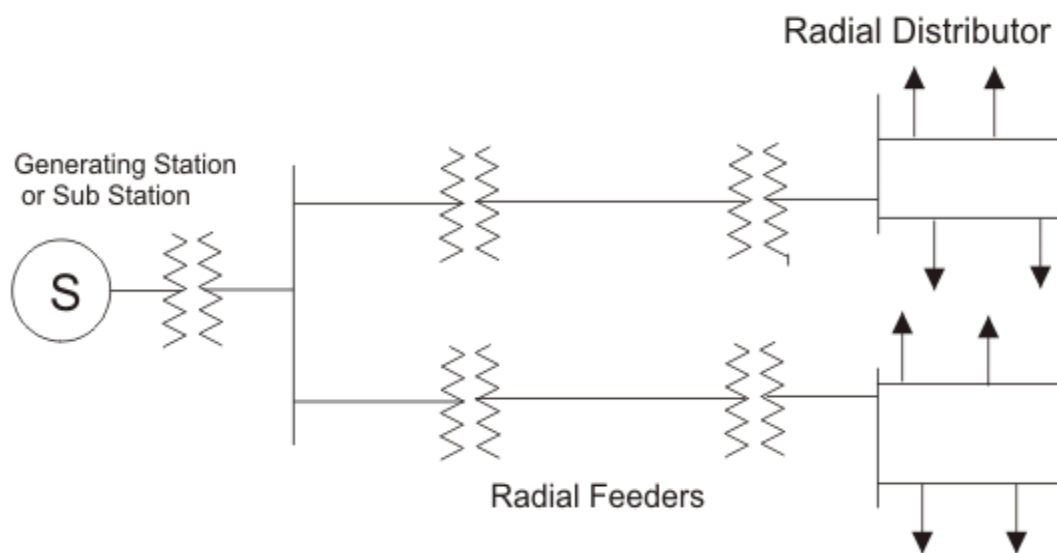

Figure3. 1 Example for typical radial system [14]

3.2. Distributed Generation

Sustained growth of electricity demand has resulted in a new challenge for power system utilities in preserving the system efficiency. A couple of years ago, the main concerns of industry and research sectors had been concentrated on establishing new strategies for distribution system scheduling concerning system efficiency enhancement. Thereby, two main competitive strategies may be employed to alleviate this challenge. These are network expansion and Distributed generation (DG) allocation within the existing distribution network. Because power system is operating nearby its boundary where network expansion is limited, due to several reasons like high costs and environmental problems. Hence, DG units-based strategy has been considered as the most appropriate solution. One of the major motivation for studies on the integration of distributed resources to the grid is the exploitation of renewable resources such as; hydro, wind, solar, geothermal, biomass and ocean energy, which are naturally scattered around the country and exhaustible. Accordingly, these resources can be tapped through integration to the distribution system using Distributed Generation (DG) units.

Distributed generation usually referred to as small-scale which usually ranges from 1 kW to 50 MW [4] electric power generators which produce electricity that found in a place near to customers or distribution system. In remote locations, DG can have even less cost when compared to the expensive construction of distribution and/or transmission lines even though the investment cost per kVA of a DG which can be much higher than that of a large power plant. Generally, DG has the following advantages;

- Provide voltage support
- Increase efficiency
- Increase reliability as standby or back up
- Decrease energy loss
- Reduce pressure on distribution and transmission lines
- Can be constructed at the load location
- A green power source that produces near zero pollution &
- Reduce the transmission cost with proximity of generation plant to heavy loads.

3.2.1. Distributed Generation Technology

- DG technologies worldwide are classified based on different related issues, such as generation type, energy source, fuel type, combustion, and generation model [15].
- Reciprocating Engines: - This DG technology was developed more than a century ago, in which pistons move back & forth in cylinders. Reciprocating engines are a subset of internal combustion engines also include rotary engines and are broadly utilized in a large array of applications. The engines range in size from less than 5 to over 5,000 kW and use diesel, natural gas, or waste gas as their fuel source. Development efforts remain focused on improving efficiency and on reducing emission levels. Reciprocating engines are being used primarily for backup power, peaking power, and in cogeneration applications.
- Micro-turbines: - A new and emerging technology, micro-turbines are available from a few manufacturers. Other manufacturers are looking to enter this emerging market, with models ranging from 30 to 200 kW. Micro-turbines give low emission levels, but the units are currently relatively costlier. Obtaining reasonable costs and demonstrating reliability will be major hurdles for manufacturers. Micro-turbines are just entering the marketplace, and most installations are to test the technology [15].
- Photovoltaic: - Photovoltaic (PV) is a technology that produces electrical energy from solar radiation. PV cell are made up of two or more thin layers of semiconductor material, mostly silicon [16]. PV usually known as solar panels, photovoltaic (PV) panels are broadly available for commercial and domestic use. Panels range from less than 5 kW, and units can be combined to form a system of different size. They produce negligible emissions and require minimal maintenance. However, they can be quite costly. Less expensive components and advancements in the manufacturing process are required to eliminate the economic barriers now impeding wide-spread use of PV systems. Photovoltaic is currently being used primarily in remote locations without grid connections and to generate green power [15].
- Fuel cells: -Even though the first fuel cell was developed more than a hundred fifty years ago, this technology still now is in development. Currently, fuel cells are commercially found from only one manufacturer, with others developing units in the 5 to 1000kW size to enter the market in the next year.

Fuel cell emission levels are very low but cost and demonstrated reliability remain significant problems for the market penetration of this technology. The few fuel cells being used provide premium power are in applications subsidized by the government or gas utilities.

- **Wind Turbines:** - Wind Turbine is made of a rotor, turbine blades, generator, drive or coupling device, shaft, and the nacelle (turbine head) that contains the gearbox and the generator drive [17]. Wind turbines are currently found from many manufacturers and range in size from less than 5 to over 1,000 kW. They provide a relatively cheap (compared to other renewables) way to generate electricity, but as they depend on the variable and somewhat unpredictable wind, are unsuitable for continuous power needs.

3.2.2. Optimal sizing and allocation of distribution generator

Line losses are divided into real and reactive components by considering only reactive component it is potentially affected by the installed capacitors. Unlike shunt capacitors, DG units are not limited to reactive power generation as they can deal with real and reactive power at the same time which is of having great importance. To this end, the connection of DG units on distribution feeders has a wide impact on the performance of the distribution network relative to others. With the optimal sizing and allocation of distribution generators, enormous benefits could be achieved regarding reducing power and energy losses, releasing KVA capacity, improving voltage profile, real and reactive power flow control, improving network reliability amongst others. Allocation of distributed generation is defined as the fixing and operation of electric power generation units connected right to the distribution network or connected to the network on the customer site of the energy meter.

There has been a different method used for optimal sizing and allocation of distribution generator. This method can be classified into three types:

- **Numerical method:** - involves the use of numerical analysis in searching for an optimal solution. The main advantage of this method is that it guarantees finding the global optimum; however, it is mostly not suitable for large scale systems. The different types of numerical methods that have been used so far including gradient search, linear programming, nonlinear programming, sequential quadratic programming, exhaustive search, etc. [18].

- **Analytical method:** - This method originated from the 2/3 rule and is mostly executed based on the exact loss formula for active power in a system. Analytical methods are easy to implement and execute, but their results are only indicative since they make simplifying assumptions including the consideration of only one power system loading snapshot. [18]
- **Heuristic and meta-heuristic method:** - This method involves creating a minimization or maximization objective function in finding the optimal DG placement and size. It could be classified as either an experience-based technique (i.e., Heuristic) or higher-level (i.e., meta-heuristic) method, which does not require training in searching for the iterative optimal solution. Heuristic methods are usually robust and provide near-optimal solutions for massive, complex optimal DG placement problems. Generally, they require high computational effort. Some types of heuristic and meta-heuristic solution methods used in optimal DG placement include Genetic Algorithm (GA), Tabu search, Particle Swarm Optimization (PSO), Ant Colony Optimization (ACO), Artificial Fish Swarm Algorithm (AFSA), Harmony Search, Firefly Algorithm (FA), etc. [18].

3.3. Power flow analysis of radial distribution system

Distribution power flow or load flow problem is the process of finding the operating point of a distribution network at steady state under given circumstances of load and cogeneration and formulated as a set of precisely known nonlinear algebraic equations that must be solved simultaneously. The first step in load flow analysis is the finding of all the bus voltages. From these voltages, it is possible to estimate currents, power flows, system losses, and other steady-state quantities. A well-organized load-flow study can be used for optimal conductor selection at the stage of system planning and for the system optimization and stability studies [19]. Current power distribution network is challenged continuously with ever-rising load demand. Distribution networks face different changes every day from a low to high load level. The load flow analysis is important for the continuous evaluation of the existing power system and for planning of alternatives for system expansion to meet increased load demand in future. These analyses require the calculation of various load flows for both normal and emergency operating modes. The power flow studies are helpful to confirm selected switchgear, transformer, and cable sizing, and can be used to assure adequate voltage profiles during different operating conditions, such as heavily loaded and lightly loaded system conditions.

Hence, to evaluate and examine the performance of a power distribution system and the effectiveness of planned modifications to a system in the planning stage, it is necessary to perform load flow analysis of the system repeatedly.

The radial distribution networks because of some unique features fall in the category of ill-condition, like as radial or weakly meshed networks. The efficient and reliable load flow solution techniques like Gauss-Seidel, Newton-Raphson and fast decoupled load flow have been failed with a radial distribution network, due to special characteristics such as, it is radial or weakly meshed, the lines have high R/X ratio, and it is usually unbalanced by nature. So, to alleviate this gap, backward/forward sweeping method is introduced to analyze the distribution network [20].

3.3.1. Backward/Forward Sweep Method

The radial distribution network has a unique feature of is that there is a unique path from any given bus back to the source. The backward/forward sweep algorithm generally takes advantage of the radial network topology and consist of forwarding and/or backward sweep processes. It is based on updating voltages and currents along these unique paths. In the BFS technique, the network is assumed to be balanced, as such; it is represented by an equivalent single line diagram. The analysis proceeds from one branch to another in a systematic way until all the branches in the feeders have been traced.

Forward sweep

- Update end voltages as a function of currents or power flows injected into each lateral by voltage drop calculation. It based on the boundary condition of the specified source voltage.
- It is primarily a voltage drop calculation with possible current or power flow updates.
- Nodal voltages are updated in a forward sweep starting from branches in the first layer toward those in the last.
- The feeder substation voltage is scheduled at its actual value.
- During the forward propagation, the effective power in each branch is held constant to the value obtained in a backward walk.

Backward sweep

- Update currents or power flows injected into each lateral as a function of end voltages by current or power flow summation. It based on the boundary condition of zero current or power flow out of the end of the lateral.
- It is starting from the branches in the end node and moving towards the branches connected to the source node.
- The updated effective power flows in each branch are obtained in the backward propagation computation by considering the node voltages of the previous iteration.
- It means the voltage values obtained in the forward path are held constant during the backward propagation and updated power flows in each branch are transmitted backward along the feeder using the backward path.

3.4. Particle swarm optimization

Optimization is the major act of obtaining the best result in given situations even though there is no well identified single optimization method available for solving all optimization problems. Numerous optimization techniques have been developed for solving different types of optimization challenges in recent years. The advanced optimization methods (sometimes called nontraditional optimization methods) are potent and popular methods for solving complex engineering problems. These methods include a particle swarm optimization algorithm, neural networks, genetic algorithms, ant colony optimization, artificial immune systems, and fuzzy optimization. Particle Swarm Optimization (PSO) is a novel population-based stochastic search algorithm and an alternative solution to the complex non-linear optimization problem that was introduced by James Kennedy and Russell Eberhart in 1995.

PSO takes its inspiration from the behavior of the social behavior of animals such as birds, fishes, insects and their communities, and how they manage as a group, rather than as individuals, recreating themselves and adapting in accordance with the changes in the surrounding environment, to search for food or to migrate [21]. PSO is mainly inspired by social behavior patterns of organisms that live and interact with a large group, and the members of the entire population are maintained through the search procedure.

While looking for food, the birds are either dispersed or go together before they locate the place where they can get the food. While the birds are looking for food from one place to another, there is always a bird that can smell the food effectively, that is, the bird is perceptible of the place where the food can be found, having the better food resource information. Because they are delivering the information, especially the good information at any time while searching the food from one place to another, conducted by the good information, the birds will eventually travel to the place where food can be found. As far as particle swarm optimization algorithm is concerned, solution swam compared to the bird swarm, the birds' moving from one place to the next another is equivalent to the development of the solution swarm, useful information is equal to the most optimist solution, and the food resource is equal to the most positive solution during the whole course.

The PSO method is becoming well known because of its simplicity of implementation as well as the ability to swiftly meet to a good solution. It does not require any information of the function to be optimized and uses only original mathematical operators. Relative to other optimization methods, it is quick, cheaper and more efficient. Also, there are few parameters to modify in PSO. That's why PSO is an ideal optimization problem solver in optimization problems. PSO is well suited to solve the non-linear, non-convex, continuous, discrete, integer variable type problems [24].

3.4.1. Basic Particle Swarm Optimization Algorithm

In a PSO algorithm, individual member is called "particle," & each particle flies around in the multi-dimensional search space with a velocity, which is updated continuously by the particle's own experience and experience of the particle's neighbors or the experience of the whole swarm. Two variants of the PSO algorithm are developed namely PSO with a local neighborhood, and PSO with a global neighborhood which differs in the size of their neighborhoods. According to the global neighborhood, each particle moves towards its best previous position and towards the best particle in the whole swarm, called global best model. It uses a star social network topology, and it obtained the social information from all particles in the entire swarm. On the other hand, according to the local variant so-called local best, each particle moves towards its best previous position. It reflects a ring social topology, and the social information exchanged within the neighborhood of the particle, denoting local knowledge of the environment [23].

Therefore, it is important to note that the personal best is the best position that the individual particle has visited since the first-time step and obtains the information from only its immediate neighbors in the swarm. On the other hand, the global best position is the best position discovered by any of the particles in the entire swarm and obtains the information from the best particle in the entire swarm.

A fundamental Particle Swarm Optimization algorithm simple as it involves only two model equations. In PSO, the coordinates of individual particle represent a possible solution associated with two vectors, the position (X_i) and velocity (V_i) vectors. The size of the vectors X_i and V_i are equal to the problem space dimension. A swarm consists of several particles “or possible solutions” that proceed (fly) through the feasible solution space to explore optimal solutions. At each step of the iteration, the velocity of each particle will change towards its pbest and gbest in the global version. After that, the new position for each particle will be calculated by adding the last position to the new velocity. The two main equations are as follows below.

$$V_i^{k+1} = \omega V_i^k + C_1 * rand * (pbest_i - X_i^k) + C_2 * rand * (gbest_i - X_i^k) \quad (3.1)$$

$$X_i^{k+1} = X_i^k + V_i^{k+1} \quad (3.2)$$

Where

- V_i^k : is the i^{th} velocity component at iteration k,
- X_i^k : is the current position in the i^{th} dimension,
- $rand$: is random number between 0 and 1,
- C_1, C_2 : are the acceleration coefficients that are usually set to 2.0,
- $pbest_i$: is the personal best position in the i^{th} dimension,
- $gbest_i$: is the global best position in the i^{th} dimension,
- ω : is the inertia weight

The basic elements of the PSO techniques are

1. **Particle X (I):** It is a candidate solution represented by a D dimensional real-valued vector, where D is the number of optimized parameters.

At time t , the i^{th} particle (I) can be described as $x_i(I) = [x_{i,1}(I); x_{i,2}(I); \dots; x_{i,D}(I)]$. Each particle modifies its position according to:

- Its current position,
 - Its current velocity,
 - The distance between its current position and pbest and
 - The distance between its current position and gbest.
2. **Population:** it is a set of x particles at time t .
 3. **Fitness Function:** Fitness Function is the function used to find the optimal solution. Usually it is an objective function.
 4. **Swarm:** it is an apparently disorganized population of moving particles that tend to cluster together while each particle seems to be moving in a random direction.
 5. **Particle velocity $V(I)$:** It is the velocity of the moving particles, which is a vector to determine the speed and direction. It is represented by a D dimensional real valued vector. At time t , the i^{th} particle $v(I)$ can be described as $v_i(I) = [v_{i,1}(I); v_{i,2}(I); \dots; v_{i,D}(I)]$
 6. **Velocity Update:** Velocity is updated by the equation (I).
 7. **Position Update:** -All the particles try to move toward the best position for optimal fitness. Each particle in PSO updates their positions to find the global optima.
 8. **Inertia weight $w(I)$:** It is a control parameter that is used to control the impact of the previous velocity on the current velocity.
 9. **Individual best (pb_i):** - As the particle moves through the search space, it compares its fitness value at the current position to the best fitness value it has ever attained at any time up to the current time. The best position that is associated with the best fitness met so far is called the individual best for each particle in the swarm, can be determined and updated during the search. Generally, it is the best position of the particle among its all positions visited so far.
 10. **Global best (gb_i):** -It is the best position where the best fitness is achieved among all the individual best positions visited so far.
 11. **Stopping criteria:** -These are the conditions under which the search process will terminate.

In this study, the search will terminate if the number of the iterations since the last change of the best solution is greater than a pre-specified number or if the number of iterations reaches the maximum allowable number.

3.4.2. PSO Algorithm Parameters

There are some parameters in PSO algorithm that may affect its performance. For any given optimization problem, some of these parameter's values and options have an enormous effect on the efficiency of the PSO method, and other parameters have small or no effect [22]. The basic PSO parameters are:

- **Swarm size**

Swarm size or population size is the number of particles n in the swarm. A big swarm generates more significant parts of the search space to be covered per iteration. Many particles may decrease the number of iterations needs to obtain a good optimization result. In contrast, vast amounts of particles increase the computational complexity per iteration, and more time consuming. From many empirical studies, it has been shown that most of the PSO implementations use an interval of [20, 60] for the swarm size [23].

- **Particle Velocity**

The current velocity V_{id}^k is constrained in the limits $V_{id}^{min} \leq V_{id}^k \leq V_{id}^{max}$. The parameter V^{max} determines the resolution, or fitness, showing which regions are to be searched between the present position and the target position. If V^{max} is very high, particles might fly past good solutions. This is due the particles move in larger steps and the solution reached may not be optimal. Similarly if V^{max} is too small, particles take a longer time to reach desired solutions. They may even not explore sufficiently hence being captured in local minimum solutions. In many experiences with PSO, V^{max} is often set at 12–25% of the dynamic range of the variables on each dimension.

- **Random Numbers**

Achieve the stochastic behavior of PSO with uniform random values in the range [0, 1].

- **Iteration numbers**

The number of iterations to get a best result is also problem-dependent. A too small number of iterations may stop the search process early, while too large iterations have the consequence of unwanted added computational complexity and more time needed [23].

- **Velocity Components**

The velocity components are very important for updating particle's velocity. There are three terms of the particle's velocity in equation (3.1)

- 1) The term ωV_i^k is called inertia component that provides a memory of the previous flight direction that means movement in the immediate past. This component represents as a momentum which prevents to drastically change the direction of the particles and to bias towards the current direction.
- 2) The term $C_1 * rand * (pbest_i - X_i^k)$ is called cognitive component which measures the performance of the particles relative to past performances. This component looks like an individual memory of the position that was the best for the particle. The effect of the cognitive component represents the tendency of individuals to return to positions that satisfied them most in the past.
- 3) The term $C_2 * rand * (gbest_i - X_i^k)$ is called social component which measures the performance of the particles relative to a group of particles or neighbors. The social component's effect is that each particle flies towards the best position found by the swarm.

- **Acceleration coefficients**

The acceleration coefficients C_1 and C_2 , together with the random values r_1 and r_2 , maintain the stochastic influence of the cognitive and social components of the particle's velocity respectively. The constant C_1 expresses how much confidence a particle has, while C_2 expresses how much confidence a particle has in its neighbors [23].

- 1) When $C_1 = C_2 = 0$, then all particles continue flying at their current speed until they hit the search space's boundary. The velocity update equation is calculated as

$$V_i^{k+1} = \omega V_i^k \quad (3.3)$$

- 2) When $C_1 > 0$ and $C_2 = 0$, all particles are independent. The velocity update equation will be

$$V_i^{k+1} = \omega V_i^k + C_1 * rand * (pbest_i - X_i^k) \quad (3.4)$$

In other word, when $C_2 > 0$ and $C_1 = 0$, all particles are attracted to a single Point (i.e. $gbest$) and the velocity update equation will be

$$V_i^{k+1} = \omega V_i^k + C_2 * rand * (gbest_i - X_i^k) \quad (3.5)$$

- 3) When $C_1 = C_2$ all particles are attracted towards the average of $pbest$ & $gbest$.
- 4) When $C_1 \gg C_2$, each particle is more strongly influenced by its personal best position, resulting in excessive wandering.
- 5) When $C_1 \ll C_2$, then all particles are much more influenced by the global best position, which causes all particles to run prematurely to the optima [23].

3.4.3. Advantage and disadvantages of PSO algorithm

Advantages of PSO algorithm

- It can be applied both in scientific research and engineering problems because it is a straightforward implementation.
- It is efficient in global search and derivative-free algorithm.
- It has a limited number of parameters, and the impact of parameters on the solutions is small compared to other optimization techniques.
- The calculation in PSO algorithm is straightforward.
- There are some techniques which ensure convergence and the optimum value of the problem calculates easily within a short time.
- PSO is less dependent on a set of initial points than other optimization techniques.

Disadvantages of PSO

- PSO algorithm suffers from partial optimism, which degrades the regulation of its speed and direction.
- Problems with non-coordinate system (for instance, in the energy field) exit.

CHAPTER FOUR

4. PROPOSED METHODOLOGY AND MODELING

4.1. Mathematical modeling of Load flow analysis using backward/forward sweep method

Considering a branch connected between buses i and $i+1$ as shown in Figure 4.1, and by assuming radial distribution networks are balanced and can be also represented by their equivalent single line diagram, then half line charging susceptance of distribution lines are negligible and these distribution lines are represented as short lines and hence shunt capacitor banks are treated as loads.

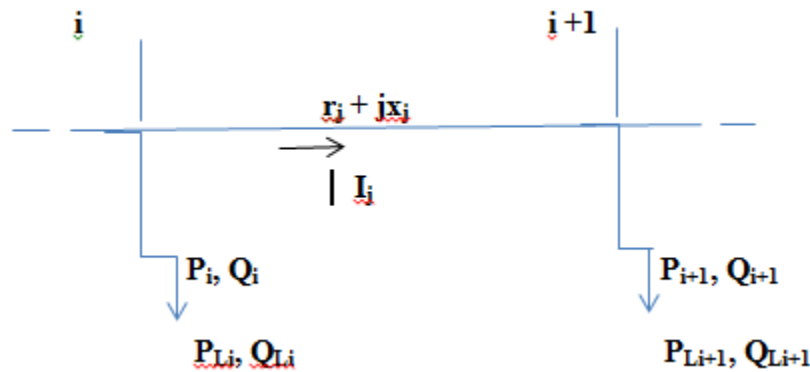

Figure 4. 1 Electrical equivalent of a typical one branch

4.1.1. Per unit calculation

$$Z_{\text{base}} = \frac{\text{KV}_{\text{base}}^2}{\text{MVA}_{\text{base}}} \quad (4.1)$$

$$R_{\text{pu}} = \frac{R_{\text{actual}}}{Z_{\text{base}}} \quad (4.2)$$

$$X_{\text{pu}} = \frac{X_{\text{actual}}}{Z_{\text{base}}} \quad (4.3)$$

$$P_{\text{pu}} = \frac{P_{\text{actual}}}{1000 * \text{MVA}_{\text{base}}} \quad (4.4)$$

$$Q_{\text{pu}} = \frac{Q_{\text{actual}}}{1000 * \text{MVA}_{\text{base}}} \quad (4.5)$$

Voltage Profile Improvement and Power Loss Minimization of Radial Distribution Feeders Using Optimal Allocation and Sizing of Distribution Generator (DG)

Where MVA_{base} is the base value of the Megawatt

KV_{base} is the base value of kilovolt

Z_{base} is the base impedance value of the line;

R_{pu} is the per unit value of resistance; R_{actual} is the actual value of resistance;

X_{pu} is the per unit value of reactance; X_{actual} is the actual value of reactance;

P_{pu} is the per unit value of the active power; P_{actual} is the actual value of active power;

Q_{pu} is the per unit value of the reactive power; Q_{actual} is the actual value of reactive power;

The effective active (P_i) and reactive (Q_i) powers that of flowing through branch ‘j’ from node ‘i’ to node ‘i+1’ can be calculated backwards from the last node and is given as,

$$P_i = P'_{i+1} + r_j \frac{(P'_{i+1})^2 + (Q'_{i+1})^2}{V_{i+1}^2} \quad (4.6)$$

$$Q_i = Q'_{i+1} + x_j \frac{(P'_{i+1})^2 + (Q'_{i+1})^2}{V_{i+1}^2} \quad (4.7)$$

Where $P'_{i+1} = P_{i+1} + P_{Li+1}$ and $Q'_{i+1} = Q_{i+1} + Q_{Li+1}$, P_{Li+1} and Q_{Li+1} are loads that are connected at node ‘i+1’, P_{i+1} and Q_{i+1} are the effective real and reactive power flows from node ‘i+1’.

The voltage magnitude and angle at each node are calculated in forward direction. Consider a voltage $V_i \angle \delta_i$ at node ‘i’ and $V_{i+1} \angle \delta_{i+1}$ at node ‘i+1’, then the current flowing through the branch ‘j’ having an impedance, $z_j = r_j + j x_j$ connected between ‘i’ and ‘i+1’ is given as,

$$I_j = \frac{(V_i \angle \delta_i - V_{i+1} \angle \delta_{i+1})}{z_j = r_j + j x_j} \quad (4.8)$$

$$\text{and } I_j = \frac{P_i - jQ_i}{V_i \angle -\delta_i} \quad (4.9)$$

On equating the equations (4.8) and (4.9), we have

$$\frac{P_i - jQ_i}{V_i \angle -\delta_i} = \frac{(V_i \angle \delta_i - V_{i+1} \angle \delta_{i+1})}{r_j + j x_j} \quad (4.10)$$

$$V_i^2 - V_i V_{i+1} \angle (\delta_{i+1} - \delta_i) = (P_i - jQ_i)(r_j + j x_j) \quad (4.11)$$

Voltage Profile Improvement and Power Loss Minimization of Radial Distribution Feeders Using Optimal Allocation and Sizing of Distribution Generator (DG)

By equating real and imaginary parts on both sides of equation (4.11), we have

$$V_i V_{i+1} \cos(\delta_{i+1} - \delta_i) = V_i^2 - (P_i r_j - Q_i x_j) \quad (4.12)$$

$$V_i V_{i+1} \sin(\delta_{i+1} - \delta_i) = Q_i r_j - P_i x_j \quad (4.13)$$

Squaring and adding equations (4.12) and (4.13), we get voltage and voltage angle; δ_{i+1} can be derived as shown below

$$(V_i V_{i+1})^2 = [V_i^2 - (P_i r_j + Q_i x_j)]^2 + [Q_i r_j - P_i x_j]^2 \quad (4.14)$$

$$(V_i V_{i+1})^2 = V_i^4 - 2V_i^2 (P_i r_j + Q_i x_j) + (r_j^2 + x_j^2)(P_i^2 + Q_i^2) \quad (4.15)$$

$$V_{i+1} = [V_i^2 - 2(P_i r_j + Q_i x_j) + (r_j^2 + x_j^2) \frac{(P_i^2 + Q_i^2)}{V_i^2}]^{1/2} \quad (4.16)$$

$$\delta_{i+1} = \delta_i + \tan^{-1} \frac{(Q_i r_j - P_i x_j)}{[V_i^2 - (P_i r_j + Q_i x_j)]} \quad (4.17)$$

The magnitude and the phase angle equations can be used recursively in a forward direction to find the voltage and angle respectively of all nodes of radial distribution system. The real and reactive power losses of branch 'j' can be calculated as,

$$P_{loss(j)} = r_j \frac{(P_i^2 + Q_i^2)}{V_i^2} \quad (4.18)$$

$$Q_{loss(j)} = x_j \frac{(P_i^2 + Q_i^2)}{V_i^2} \quad (4.19)$$

The total real and reactive power loss of radial distribution system can be calculated as,

$$T_{PL(j)} = \sum_{j=1}^{nb} r_j \frac{(P_i^2 + Q_i^2)}{V_i^2} \quad (4.20)$$

$$T_{QL(j)} = \sum_{j=1}^{nb} x_j \frac{(P_i^2 + Q_i^2)}{V_i^2} \quad (4.21)$$

Initially, a flat voltage profile is assumed at all nodes i.e., 1.0 pu. The branch powers are computed iteratively with the updated voltages at each node. In the proposed load flow method, powers summation is done in the backward walk and voltages are calculated in the forward walk.

4.1.2. Algorithm for forward backward sweep load flow

It is deemed suitable, to begin with the application of backward/forward power flow method on a 3-phase balanced load feeder [26]. In this case, the calculations are conducted in terms of line voltages and currents of single line diagram model, as in traditional power flow methods. Considering Figure 4.2, showing five nodes radial distribution feeder, the backward sweep begins from node 5 as follows:

The algorithm is developed based on two derived matrices, the bus-injection to branch-current matrix and the branch current to bus-voltage matrix, and equivalent current injections. For distribution networks, the equivalent current-injection based model is more practical. For the bus, the complex load S_i is expressed by:

$$S_i = P_i + jQ_i \quad i = 1 \dots N \quad (4.22)$$

Step 1 backward sweep

For each iteration k , branch currents are aggregated from loads to origin. But before finding the branch current we need to find the current injected at each bus and the bus-injection to branch-current (BIBC) which relates the bus injected current to the branch current.

The current injection at the k^{th} iteration of the i^{th} bus is

$$I_i^k = \left(\frac{S_i}{V_i^k} \right)^* = \left(\frac{P_i + jQ_i}{V_i^k} \right)^* \quad (4.23)$$

Where V_i^k and I_i^k are the bus voltage and equivalent current injection of the i^{th} bus at the k^{th} iteration, respectively. Matrix development for relating branch current and bus injected current at each bus,

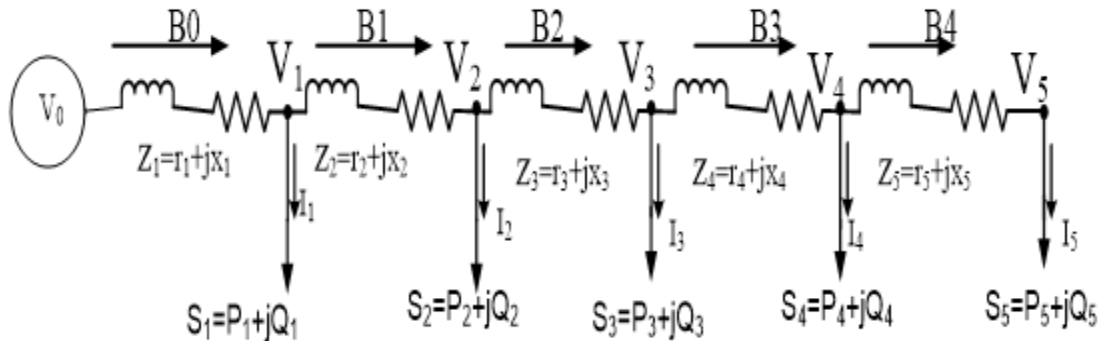

Figure4. 2 Single line diagram of 5-nodes radial distribution feeder [26].

By applying Kirchhoff's current law (KCL) to the distribution network, the branch currents are calculated as shown below using figure.4.2 as functions of equivalent current injection at each bus.

$$\begin{aligned}
 B_4 &= I_5 \\
 B_3 &= I_4 + B_4 = I_4 + I_5 \\
 B_2 &= I_3 + B_3 = I_3 + I_4 + I_5 \\
 B_1 &= I_2 + B_2 = I_2 + I_3 + I_4 + I_5 \\
 B_0 &= I_1 + B_1 = I_1 + I_2 + I_3 + I_4 + I_5
 \end{aligned} \tag{4.24}$$

The relationship between the bus current injections and branch currents can be expressed as,

$$\begin{bmatrix} B_0 \\ B_1 \\ B_2 \\ B_3 \\ B_4 \end{bmatrix} = \begin{bmatrix} 11111 \\ 01111 \\ 00111 \\ 00011 \\ 00001 \end{bmatrix} \begin{bmatrix} I_1 \\ I_2 \\ I_3 \\ I_4 \\ I_5 \end{bmatrix} \tag{4.25}$$

Equation (4.25) can be expressed as

$$[B] = [BIBC][I] \tag{4.26}$$

Where, BIBC is the bus injection branch current for the given sample network.

Step 2 forward Sweep

Nodal voltage vector V is updated from the origin to loads according to the Kirchhoff Voltage Laws (KVL), using previously calculated branch currents vector B and branch-current to bus-voltage (BCBV).

The relationship between branch currents and bus voltages as shown in Figure.5.2 can be expressed as;

$$\begin{aligned}
 V_1 &= V_0 - B_0 Z_{01} \\
 V_2 &= V_1 - B_1 Z_{12} = V_0 - B_0 Z_{01} - B_1 Z_{12} \\
 V_3 &= V_2 - B_2 Z_{23} = V_0 - B_0 Z_{01} - B_1 Z_{12} - B_2 Z_{23} \\
 V_4 &= V_3 - B_3 Z_{34} = V_0 - B_0 Z_{01} - B_1 Z_{12} - B_2 Z_{23} - B_3 Z_{34} \\
 V_5 &= V_4 - B_4 Z_{45} = V_0 - B_0 Z_{01} - B_1 Z_{12} - B_2 Z_{23} - B_3 Z_{34} - B_4 Z_{45}
 \end{aligned} \tag{4.27}$$

Where V_i is the voltage at bus i and Z_{ij} is the line impedance between bus i and bus j. As it can be seen from equations (4.27), the bus voltage can be expressed as a function of branch currents, line parameters, and the substation voltage. Therefore, the relationship between branch currents and bus voltages can be expressed as;

$$\begin{bmatrix} V_1 \\ V_2 \\ V_3 \\ V_4 \\ V_5 \end{bmatrix} = \begin{bmatrix} V_0 \\ V_0 \\ V_0 \\ V_0 \\ V_0 \end{bmatrix} - \begin{bmatrix} Z_{01} & 0 & 0 & 0 & 0 \\ Z_{01} & Z_{12} & 0 & 0 & 0 \\ Z_{01} & Z_{12} & Z_{23} & 0 & 0 \\ Z_{01} & Z_{12} & Z_{23} & Z_{34} & 0 \\ Z_{01} & Z_{12} & Z_{23} & Z_{34} & Z_{45} \end{bmatrix} \begin{bmatrix} B_0 \\ B_1 \\ B_2 \\ B_3 \\ B_4 \end{bmatrix} \quad (4.28)$$

The general form for the bus voltage at (k+1)th iteration can be expressed as

$$[V^{k+1}] = [V_0] - [BCBV][B] \quad (4.29)$$

Where, BCBV is the branch current to bus voltage which is given by the given sample network.

In general form, with i and k denoting the node and iteration number respectively,

$$I_{i-1,i}^k = I_i^k + I_{i,i+1}^k \quad (4.30)$$

$$V_i^k = V_{i-1}^k - Z_{i-1,i} * I_{i-1,i}^{k-1} \quad (4.31)$$

4.1.3. Procedure Forming BIBC and BCBV Matrix

Procedure 1: Forming BIBC:

Step1: For a distribution system with m-branch section and n-bus, the dimension of the BIBC matrix is m × (n-1).

Step 2: If a line section (B_k) is located between bus i and bus j, copy the column of the ith bus of the BIBC matrix to the column of the jth bus and fill a 1 to the position of the kth row and the jth bus column.

Step 3: Repeat step (2) until all line sections are included in the BIBC matrix.

Procedure 2: Forming BCBV:

Step1: For a distribution system with m-branch section and n-bus, the dimension of the BCBV matrix is (n-1) × m.

Step 2: If a line section is located between bus i and bus j, copy the row of the ith bus of the BCBV matrix to the column of the jth bus and fill the line impedance (Z_{ij}) to the position of the kth column and the jth bus row.

Step 3: Repeat step (2) until all line sections are included in the BCBV matrix.

4.1.4. Flow chart for Forward Backward Sweep method

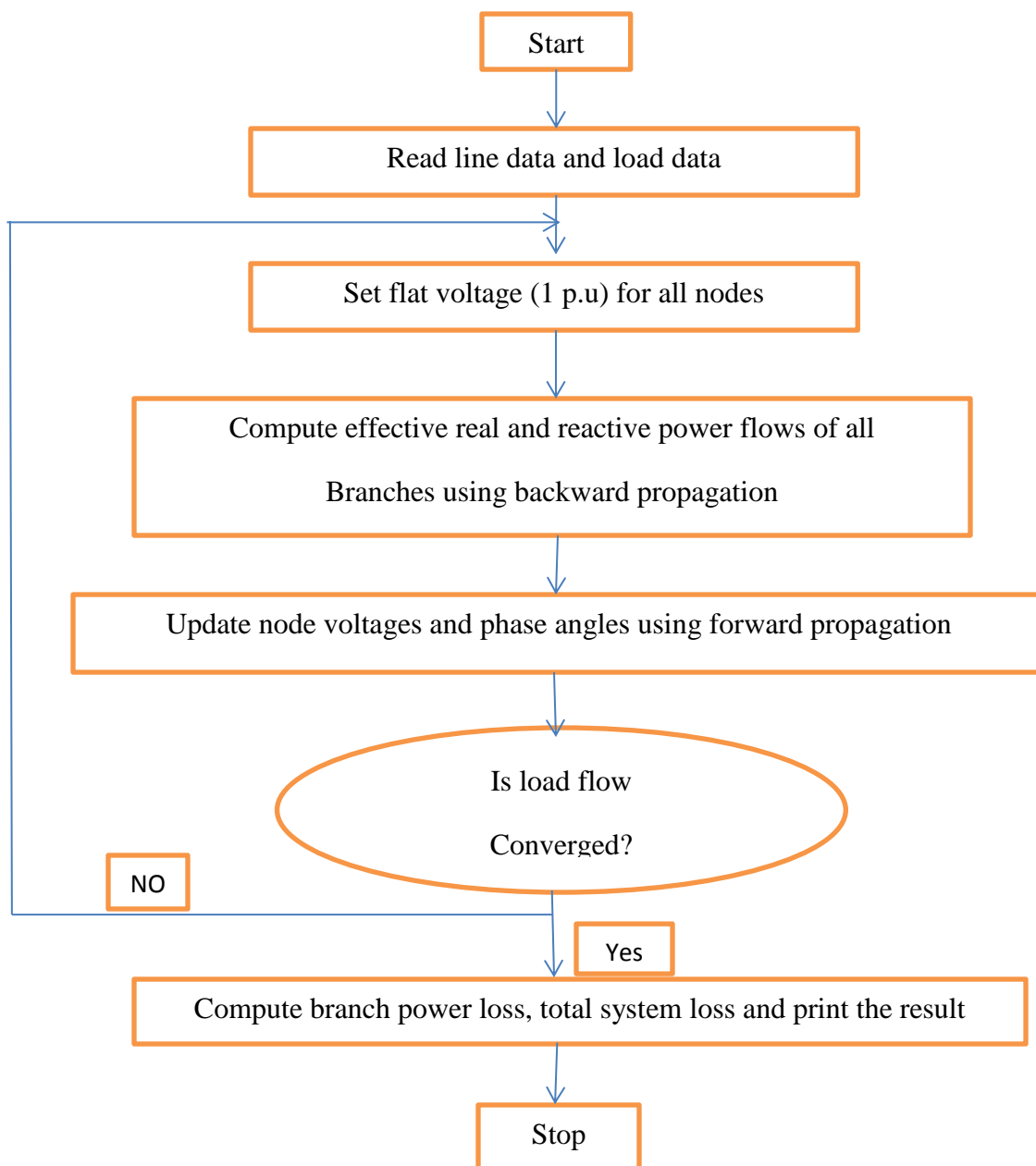

Figure4. 3 Flow chart for forward/backward load flow analysis

4.1.5. Power flow analysis using FBS method by considering DG units

When DG is applied to the system as a negative load, the total load gets reduced by the amount of power that the DG produced. Mathematically if DG is installed at bus i , the equivalent load can be stated as;

$$P_i = P_{Li} - P_{DG_i} \quad (4.32)$$

$$Q_i = Q_{Li} - Q_{DG_i} \quad (4.33)$$

Where P_{Li} and Q_{Li} the real and reactive load at bus i and

P_{DG_i} and Q_{DG_i} are the real and reactive power injected by DG at bus i.

4.2. Optimal sizing and allocation of DG using analytical method

The optimal DG sizing helps in finding a reliable solution for load flow. The optimal sizing of DG using analytical method for different types of DGs can be modeled mathematically based on exact loss formula. The total active loss in a distribution system with N-number of buses as a function of active and reactive power injections can be calculated which is formulated as;

$$P_{\text{loss}} = \sum_{i=1}^N \sum_{j=1}^N [\alpha_{ij}(P_i P_j + Q_i Q_j) + \beta_{ij}(Q_i P_j - P_i Q_j)] \quad (4.34)$$

$$\text{where, } \alpha_{ij} = \frac{r_{ij}}{V_i V_j} \cos(\delta_i - \delta_j) \quad (4.35)$$

$$\beta_{ij} = \frac{r_{ij}}{V_i V_j} \sin(\delta_i - \delta_j) \quad (4.36)$$

N is the bus number and P_i, P_j, Q_i and Q_j are the active and reactive power injections at buses i & j respectively.

α_{ij} and β_{ij} are the loss coefficients & $r_{ij} + jx_{ij} = z_{ij}$, The impedance matrix of the ij_{th} element.

If a DG is connected at bus i, then the reactive power output of the DG computed as

$$Q_{DG_i} = a P_{DG_i} \quad (4.37)$$

$$a = (\text{sign}) \tan(\cos^{-1}(\text{pf}_{DG})) \quad (4.38)$$

Where,

Sign is +1, DG is injecting reactive power

Sign is -1, DG is consuming reactive power

PF_{DG} is the power factor of DG.

P_{DG_i} & Q_{DG_i} are the active & reactive power injected at bus i, where the DG is located

Voltage Profile Improvement and Power Loss Minimization of Radial Distribution Feeders Using Optimal Allocation and Sizing of Distribution Generator (DG)

Then the power flow at bus i will be,

$$P_i = P_{DG_i} - P_{D_i} \quad (4.39)$$

$$Q_i = Q_{DG_i} - Q_{D_i} = aP_{DG_i} - Q_{D_i} \quad (4.40)$$

Substituting the above two equations eq.4.39 & 4.40 in to equation 1, the actual power loss can be written as,

$$P_{loss} = \sum_{i=1}^N \sum_{j=1}^N [\alpha_{ij} [(P_{DG_i} - P_{D_i})P_j + (aP_{DG_i} - Q_{D_i})Q_j] + \beta_{ij} [(aP_{DG_i} - Q_{D_i})P_j - (P_{DG_i} - P_{D_i})Q_j] \quad (4.41)$$

The total active power loss can be minimized if the partial derivative of eq. 4.41 with respect to the active power injection from the DG unit at bus i is equal to zero. Then it can be equated as,

$$\frac{\partial P_{loss}}{\partial P_{DG_i}} = \partial \sum_{j=1}^N [\alpha_{ij} (P_j - aQ_j) + \beta_{ij} (aP_j - Q_j)] = 0 \quad (4.42)$$

$$0 = \alpha_{ii} (P_i + aQ_i) + \beta_{ii} (aP_i - Q_i) + \sum_{\substack{j=1 \\ j \neq i}}^N (\alpha_{ij} P_j - \beta_{ij} Q_j) + a \sum_{\substack{j=1 \\ j \neq i}}^N (\alpha_{ij} Q_j - \beta_{ij} P_j) \quad (4.43)$$

By substituting equation 6 & 7 in to equation 10,

$$\alpha_{ii} ((P_{DG_i} - P_{D_i}) + a(aP_{DG_i} - Q_{D_i})) + \beta_{ii} (a(P_{DG_i} - P_{D_i}) - (aP_{DG_i} - Q_{D_i})) + x_i + ay_i = 0 \quad (4.44)$$

Where,

$$x_i = \sum_{\substack{j=1 \\ j \neq i}}^N (\alpha_{ij} P_j - \beta_{ij} Q_j)$$

$$y_i = \sum_{\substack{j=1 \\ j \neq i}}^N (\alpha_{ij} Q_j - \beta_{ij} P_j)$$

$$\alpha_{ii} ((P_{DG_i} (1 + a^2)) - (P_{D_i} + aQ_{D_i})) + \beta_{ii} (Q_{D_i} - aP_{D_i}) + x_i + ay_i = 0 \quad (4.45)$$

$$P_{DG_i} = \frac{\alpha_{ii} (P_{D_i} + aQ_{D_i}) + \beta_{ii} (aP_{D_i} - Q_{D_i}) - x_i - ay_i}{\alpha_{ii} (1 + a^2)} \quad (4.46)$$

Using equation (4.46) the optimal size of DG at each bus i that can minimize power loss.

The optimal power factor of DG at bus i can be found by partial derivative of equation (4.42) with respect to a_i .

i.e,

$$\frac{\partial P_{loss}}{\partial a_i} = \partial \sum_{j=1}^N [\alpha_{ij} Q_j + \beta_{ij} P_j] = 0$$

$$\alpha_{ii} Q_i + y_i = 0 \quad (4.47)$$

$$Q_i = \frac{-y_i}{\alpha_{ii}} \quad (4.48)$$

Voltage Profile Improvement and Power Loss Minimization of Radial Distribution Feeders Using Optimal Allocation and Sizing of Distribution Generator (DG)

$$a_i P_{DGi} - Q_{Di} = \frac{-y_i}{\alpha_{ii}} \quad (4.49)$$

$$a_i = \frac{1}{P_{DGi}} \left(Q_{Di} - \frac{y_i}{\alpha_{ii}} \right) \quad (4.50)$$

Since, $P_{DGi} = P_{Di} - \frac{x_i}{\alpha_{ii}}$

$$a_i = \frac{1}{P_{Di} - \frac{x_i}{\alpha_{ii}}} \left(Q_{Di} - \frac{y_i}{\alpha_{ii}} \right)$$

$$a_i = \frac{\alpha_{ii}}{\alpha_{ii} P_{Di} - x_i} \left(Q_{Di} - \frac{y_i}{\alpha_{ii}} \right)$$

$$a_i = \frac{\alpha_{ii} Q_{Di} - y_i}{\alpha_{ii} P_{Di} - x_i}$$

$$\text{PF of DG} = \cos(\tan^{-1}(\frac{\alpha_{ii} Q_{Di} - y_i}{\alpha_{ii} P_{Di} - x_i})) \quad (4.51)$$

In line with this, DG units can be classified in to four types depending on consuming and injection of real & reactive power, and power factor of DG can be assumed based on the type of DG.

Type1 DG:

- Injecting only real power,
- The power factor is unity. So, a = 0

Examples: fuel cell, PV, which are integrated to the main grid with the help of converters/ inverters.

The size of DG can be obtained by equation

$$P_{DGi} = P_{Di} - \frac{\beta_{ii} Q_{Di} + x_i}{\alpha_{ii}} \quad (4.52)$$

Type2 DG:

- Injecting only reactive power,
- Power factor is zero. so, a= ∞

Example: synchronous generator

Voltage Profile Improvement and Power Loss Minimization of Radial Distribution Feeders Using Optimal Allocation and Sizing of Distribution Generator (DG)

The size of DG can be obtained by equation

$$Q_{DGi} = Q_{Di} - \frac{\beta_{ii}P_{Di} + y_i}{\alpha_{ii}} \quad (4.53)$$

Type3 DG:

- Injecting both real & reactive power,
- Power factor is leading. So, a is positive

Example: synchronous machine as cogeneration

The size of DG can be obtained by equation

$$P_{DGi} = \frac{\alpha_{ii}(P_{Di} + aQ_{Di}) + \beta_{ii}(aP_{Di} - Q_{Di}) - x_i - ay_i}{\alpha_{ii}(1 + a^2)} \quad (4.54)$$

Type4 DG:

- Injecting real power and consuming reactive power
- Power factor is lagging. So, a is negative

Example: wind farms

The size of DG can be obtained by equation

$$P_{DGi} = \frac{\alpha_{ii}(P_{Di} + aQ_{Di}) + \beta_{ii}(aP_{Di} - Q_{Di}) - x_i - ay_i}{\alpha_{ii}(1 + a^2)} \quad (4.55)$$

Therefore, by using the above four equations (4.52-4.55) the optimal size for different types of DG at different buses can be determined. The only difference between equation 4.54 and 4.55 is the sign of a is positive and negative respectively.

4.2.1. Procedures for analytical method for optimal allocation and sizing

Generally steps for analytical method for optimal allocation and sizing of DG can be summarized as;

Step 1: Read the bus and line data

Step 2: Perform load flow analysis using forward backward sweep load flow algorithm

Step 3: Find the optimal size of DG for each bus and types except reference bus as discussed in section (4.2)

Step 4: Calculate power losses and voltage profiles using forward/backward sweep load flow method by placing DG of optimal size at each bus.

Step 5: Choose the bus corresponding to minimum losses and best voltage profile improvement as best location.

4.3. Optimal sizing and allocation of DG using particle swarm optimization

PSO is one method of optimization to minimize real power loss of distribution network. In this thesis it is used for finding the optimal size of distribution generator.

4.3.1. Optimal allocation of DG

The power injections from renewable DG units located close to the load centers provide an opportunity for system voltage support, reduction in energy losses and emissions, and reliability improvement. It is a prior to select the best place(s) in the system and loss sensitivity approach can be used for this purpose. The total power loss against injected power is a parabolic function and at minimum loss the rate of change of loss with respect to injected power becomes zero as shown in equation (4.56)

$$\alpha_i = \frac{\partial PL}{\partial P_i} = 2 \sum_{j=1}^N (\alpha_{ij} P_j - \beta_{ij} Q_j) \quad (4.56)$$

4.3.2. PSO Implementation Steps

In PSO algorithm, the number of population n particles are considered which represents solutions candidate. Every particle is an m dimensional real value vector where m is the number of parameters to be optimized. Consequently, each optimized parameter denotes a dimension of the problem space. The PSO technique can be described in the following steps with objective function of;

$$\min f(P_L) = \sum_{n=1}^{N_b} i_n^2 r_n \dots\dots\dots (4.57)$$

Where, N_b = maximum number of branch, i_n =current at n branch and r_n = resistance at n branch.

Step 1: Initialization: Set $k= 0$ and generate random N particles $\{X_i(0); i= 1, 2, \dots N\}$ and define all parameters. Where, K is the constant used to identify the number of iterations.

Each particle is considered to be a solution for the problem and each particle in the initial population is evaluated using the objective function f . In this study, the objective function is the power loss and voltage in the network, which will be calculated after running the backward forward sweep load flow.

Step 2: Counter updating: Update the counter $k =k+ 1$.

Step 3: Compute the objective function: Calculate the objective function and fitness value of each particle. The fitness value of each particle during the first iteration becomes its P_{best} . The best fitness value among all the P_{best} is denoted as G_{best} .

Step 4: Velocity updating: Using the global best and individual best, the i^{th} particle velocity in the d^{th} dimension is updated according to equation (3.1). Then, check the velocity limits. If the velocity violated its limit, set it at its proper limit. The second term of the above equation represents the cognitive part of the PSO where the particle changes its velocity based on its own thinking and memory. The third term represents the social part of PSO where the particle changes its velocity based on the social psychological adaptation of knowledge.

Step 5: Position updating: Each particle updates its position based on its best exploration, best swarm overall experience, and its previous velocity vector Based on the updated velocity, each particle changes its position according to equation (3.2).

Step 6: Individual best updating: Each particle is evaluated and updated according to the update position.

Step 7: global best updating

Voltage Profile Improvement and Power Loss Minimization of Radial Distribution Feeders Using Optimal Allocation and Sizing of Distribution Generator (DG)

Step 8: Minimum value search: Search for the minimum value in the individual best for all iterations and consider it as the best solution.

Step 9: Stopping criteria: If one of the stopping criteria is satisfied, then stop; otherwise go to Step 2.

4.3.3. Flow chart of PSO algorithm for optimal sizing of DG

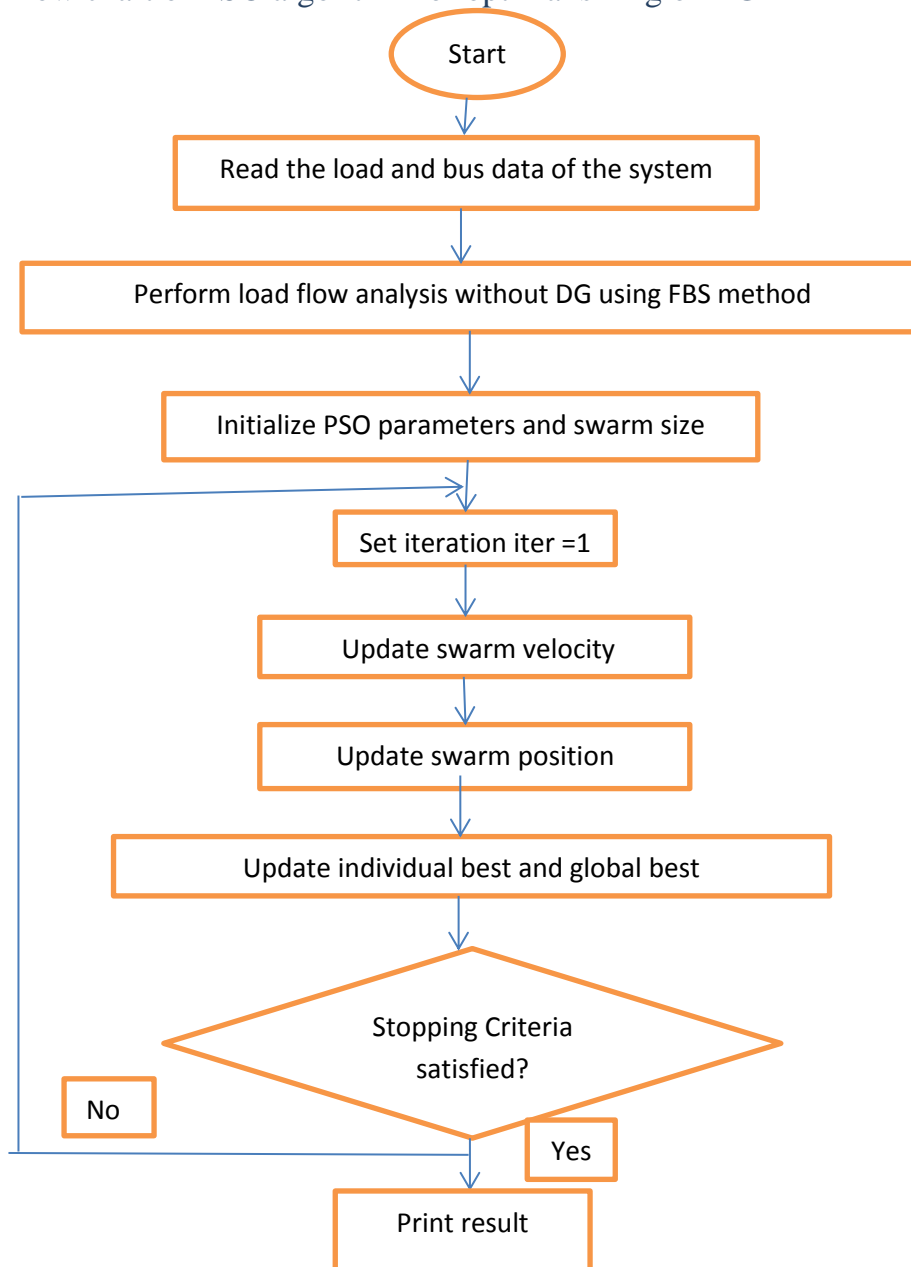

Figure 4. 4 Flow chart for PSO in optimal sizing of DG

4.4. Optimization of DG using HOMER software

HOMER which stands for Hybrid Optimization Model for Electric Renewables is developed by Mistaya Engineering, Canada for the National Renewable Energy Laboratory (NREL) USA in 1993. It is micro power optimization model that ease the task of evaluating designs of both off-grid and grid-connected power systems for various applications [27].

HOMER does both optimization and sensitivity analysis, it used for system achieves the energy balance calculation using several numbers and sizes of component. A sorted list of configuration result based on the Total Net Present Cost (TNPC) has been displayed on the software. The system takes account the calculations for costs such as capital, replacement, operation and maintenance, fuel and interest. Sensitivity analysis determines varying factors such as wind speed, fuel cost. HOMER displays simulation results in a variety of tables and graphs which helps to compare configurations and evaluate them on their economic merits.

The main components for HOMER includes,

- **Load profile:-** Load profile is essential for designing a system possible of meeting the requirements for an entity consuming electricity.
- **Renewable resources:-**The resource data have been utilized based on the type of optimal DG obtained from analytical methods. The data is taken from NASA by selecting Jimma as location under case study and Solar radiation and Temperature data are collected.
- **Technologies:-**There are different technologies available in HOMER like Grid, PV, wind turbine, diesel, etc. Among those grid, PV, Battery and converters are considered according to the desired system for the case of this thesis.

CHAPTER FIVE

5. RESULTS AND DISCUSSION

5.1. Test system

This thesis work is performed based on IEEE 33 bus system and its schematic diagram is shown in figure 5.1 below. This network has a voltage of 12.66 kV with maximum and minimum voltage limits for all buses are considered at $\pm 5\%$. The network is fed by a synchronous generator and load size of 3.715MW and 2.300 MVar. It consists of 32 line and 33 buses. The line and load data for this system is given in appendix A. load variation, such as full load, 50% and 150% of full load conditions are considered for this test system.

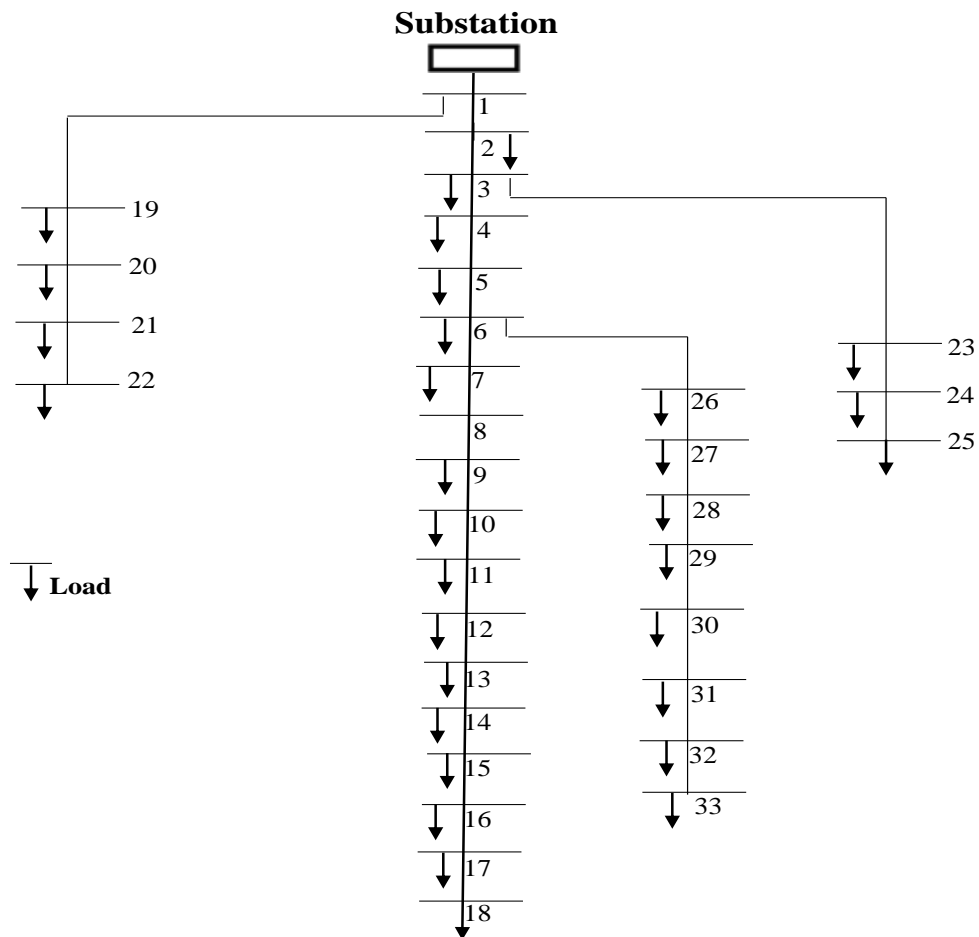

Figure5. 1 Single line diagram for IEEE 33 bus system

5.2. Simulation result on load flow analysis using FBS method without DG

A load flow analysis has been performed using forward backward method in MATLAB is run by using line and load data given in appendix A. By considering three cases with load variation voltage profile obtained without DG shown in table 5.1 below

Table 5. 1 Voltage profile for three cases of load variation

Bus no	Voltage (pu)		
	@ full load	@ 50% full load	@ 150% full load
1	1.0000	1.0000	1.0000
2	0.9970	0.9986	0.9954
3	0.9830	0.9917	0.9736
4	0.9755	0.9881	0.9619
5	0.9681	0.9846	0.9503
6	0.9497	0.9757	0.9214
7	0.9462	0.9740	0.9159
8	0.9413	0.9717	0.9083
9	0.9351	0.9687	0.8984
10	0.9293	0.9659	0.8893
11	0.9284	0.9655	0.8879
12	0.9269	0.9648	0.8855
13	0.9208	0.9619	0.8758
14	0.9185	0.9608	0.8723
15	0.9171	0.9601	0.8701
16	0.9157	0.9595	0.8679
17	0.9137	0.9585	0.8648
18	0.9131	0.9582	0.8638
19	0.9965	0.9983	0.9946
20	0.9929	0.9965	0.9892
21	0.9922	0.9962	0.9882
22	0.9916	0.9958	0.9872
23	0.9794	0.9900	0.9681
24	0.9727	0.9867	0.9579
25	0.9694	0.9850	0.9528
26	0.9478	0.9748	0.9184
27	0.9452	0.9736	0.9144
28	0.9338	0.9681	0.8964
29	0.9256	0.9642	0.8835
30	0.9221	0.9625	0.8780
31	0.9179	0.9605	0.8714
32	0.9170	0.9601	0.8699
33	0.9167	0.9599	0.8695

Voltage Profile Improvement and Power Loss Minimization of Radial Distribution Feeders Using Optimal Allocation and Sizing of Distribution Generator (DG)

The voltage profile in the above table result from the load flow analysis of forward backward sweep method without DG by considering load variation. At full load and 150% of full load condition there is a voltage drop below the minimum voltage limit which is 0.95 pu, in case of 50% of full load condition all bus voltages are within acceptable limit without DG.

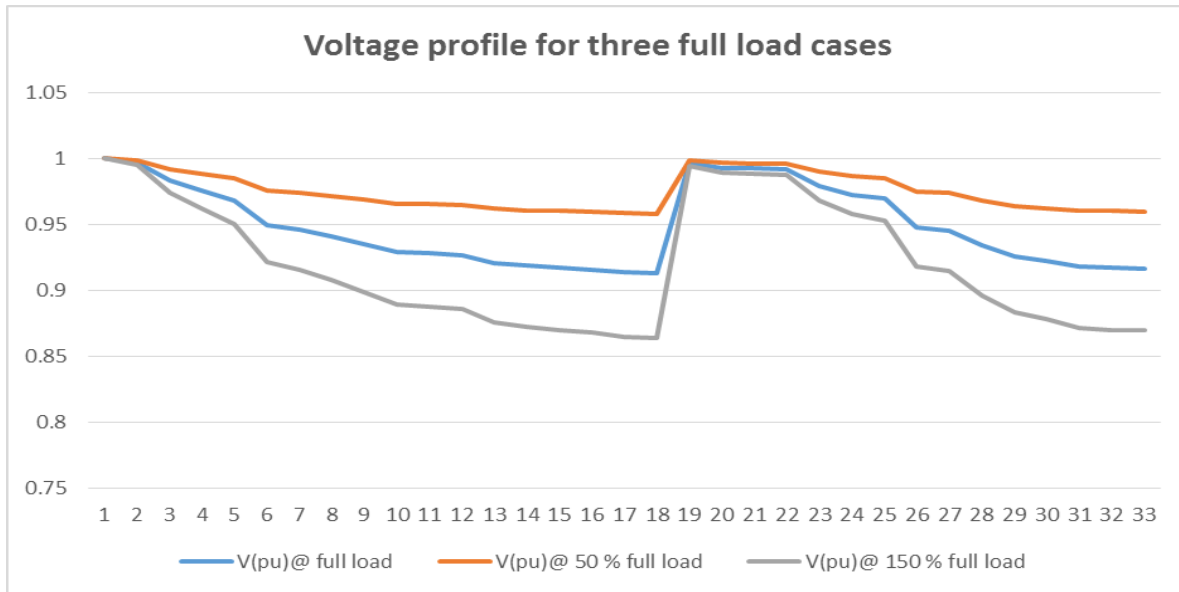

Figure5. 2 Voltage profiles at the three conditions of load before DG

The real and reactive power loss for the 32 lines under different load condition is given in table 5.2 below by forward backward sweep load flow method without DG.

Table 5. 2 Real and reactive power loss at three load conditions

line no	power loss(kw)			Power loss(kvar)		
	@full load	@ 50% FL	@150% FL	@full load	@ 50% FL	@150% FL
1.	12.2314	2.8933	29.3070	6.2351	1.4749	14.9396
2.	51.7634	12.1678	124.9028	26.3647	6.1974	63.6168
3.	19.9106	4.6181	48.7931	10.1402	2.3520	24.8498
4.	18.7094	4.3281	45.9861	9.5290	2.2044	23.4214
5.	38.2718	8.8438	94.1879	33.0381	7.6344	81.3075
6.	1.9134	0.4428	4.7015	6.3248	1.4637	15.5410
7.	4.8343	1.1138	11.9404	1.5976	0.3681	3.9460
8.	4.1762	0.9570	10.3814	3.0003	0.6876	7.4584
9.	3.5575	0.8141	8.8588	2.5216	0.5770	6.2792
10.	0.5533	0.1265	1.3796	0.1829	0.0418	0.4561
11.	0.8941	0.2042	2.2320	0.2956	0.0675	0.7380
12.	2.6876	0.6128	6.7220	2.1145	0.4821	5.2888

Voltage Profile Improvement and Power Loss Minimization of Radial Distribution Feeders Using Optimal Allocation and Sizing of Distribution Generator (DG)

13.	0.7289	0.1661	1.8251	0.9595	0.2186	2.4024
14.	0.3570	0.0812	0.8958	0.3178	0.0723	0.7973
15.	0.2815	0.0640	0.7068	0.2056	0.0467	0.5162
16.	0.2516	0.0571	0.6324	0.3359	0.0763	0.8444
17.	0.0531	0.0121	0.1336	0.0417	0.0095	0.1048
18.	0.1610	0.0400	0.3647	0.1536	0.0381	0.3480
19.	0.8322	0.2064	1.8877	0.7498	0.1860	1.7010
20.	0.1008	0.0250	0.2286	0.1177	0.0292	0.2671
21.	0.0436	0.0108	0.0990	0.0577	0.0143	0.1310
22.	3.1813	0.7723	7.3877	2.1738	0.5277	5.0479
23.	5.1434	1.2475	11.9552	4.0615	0.9851	9.4404
24.	1.2874	0.3117	2.9980	1.0074	0.2439	2.3459
25.	2.6225	0.6031	6.4914	1.3358	0.3072	3.3064
26.	3.3409	0.7672	8.2835	1.7010	0.3906	4.2175
27.	11.2798	2.5867	28.0137	9.9452	2.2806	24.6991
28.	7.8202	1.7920	19.4387	6.8128	1.5612	16.9345
29.	3.8892	0.8906	9.6758	1.9810	0.4536	4.9284
30.	1.5933	0.3635	3.9817	1.5746	0.3592	3.9351
31.	0.2131	0.0486	0.5329	0.2484	0.0567	0.6212
32.	0.0132	0.0030	0.0329	0.0205	0.0047	0.0512
Total	202.6970	47.1712	494.9580	135.1458	31.4123	330.4826

The real and reactive power loss for the three cases of load variation without DG from load flow analysis is shown in table 5.2. We can see from these the losses are high at the buses near to the substation in all cases.

5.3. Result on optimal allocation and sizing of DG using analytical method

Analytical method for determining the optimum size of different types of DG on each bus that has been discussed in section 4.2, so using those four equations for obtaining the size of DG in all buses and performing the load flow analysis minimum loss and voltage profile improvement achieved.

Case 1: at full load condition

The best result obtained is a type-1 DG with optimal location on bus 8 and optimal size of 1.88 MW. A good result on loss minimization and voltage profile improvement has been found by this optimal type, size and location of DG that has chosen. At full load condition the total real and reactive power loss with DG reduced to 110 KW from 202.69KW and 75 KVAR from 135.13KVAR respectively. The voltage profile improvement and loss minimization with and without DG is given in figure 5.3 and 5.4 as shown below.

Voltage Profile Improvement and Power Loss Minimization of Radial Distribution Feeders Using Optimal Allocation and Sizing of Distribution Generator (DG)

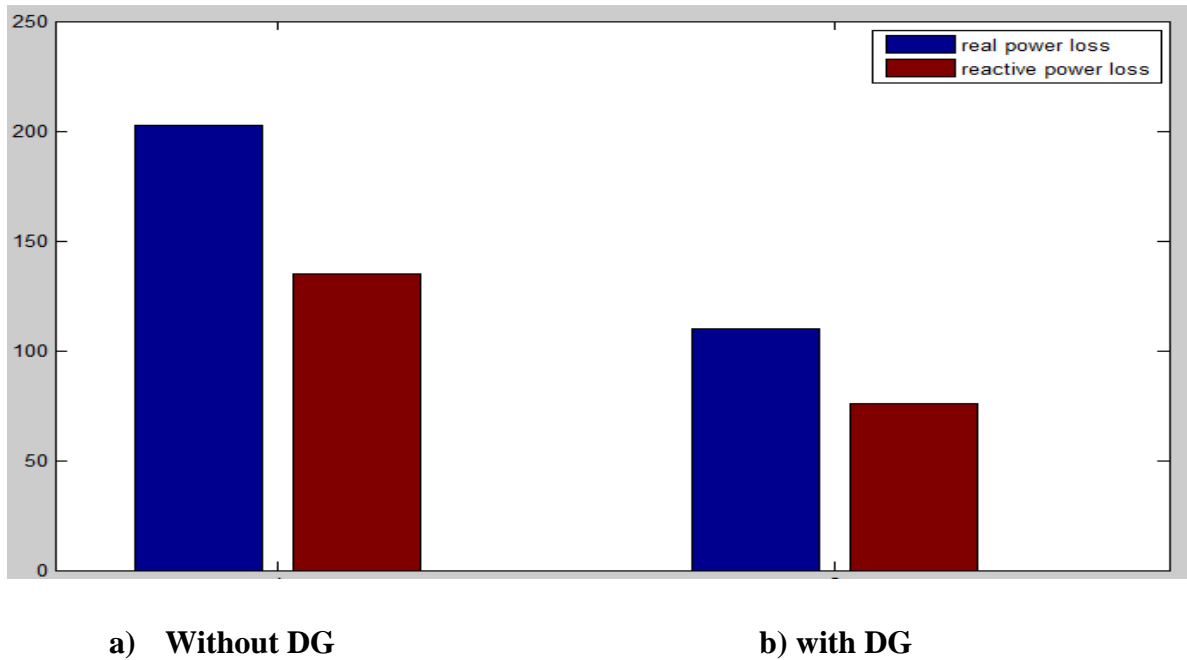

Figure5. 3 Real and reactive power loss minimization at full load case by analytical method

In other hand voltage profile improvement after DG give a satisfactory result even though voltages of 3 buses are below the limit. This can be seen from figure 5.5 the minimum voltage after optimization is 0.9458@ bus 33.

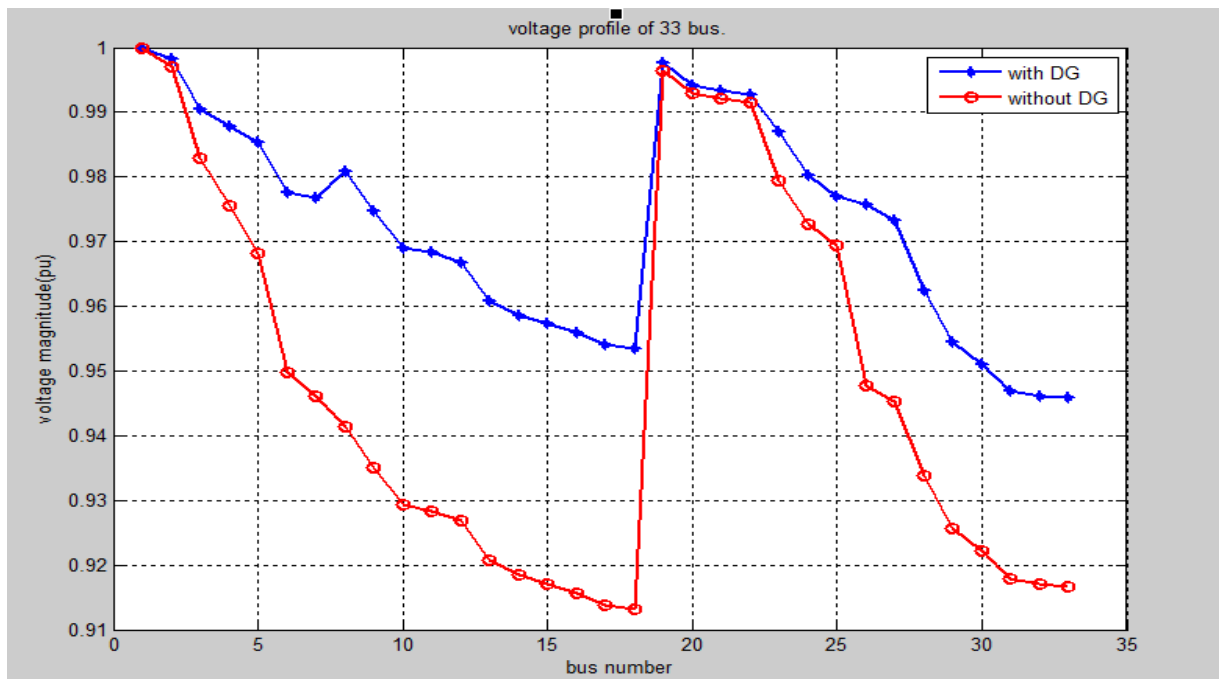

Figure5. 4 Voltage before and after placement of DG at full load case by analytical method

Case 2: at 50% of full load condition

At 50% full load condition previously before optimization power loss and voltage profile is best result obtained by a type-1 DG with optimal location on bus 8 and optimal size of 0.941 MW and the total real and reactive power loss with DG reduced to 32.29 KW from 47.17 KW and 21.50 KVAR from 31.41KVAR. Even those the voltage profile for 50% full load before optimization was not violate the standard limit with DG there is good improvement.

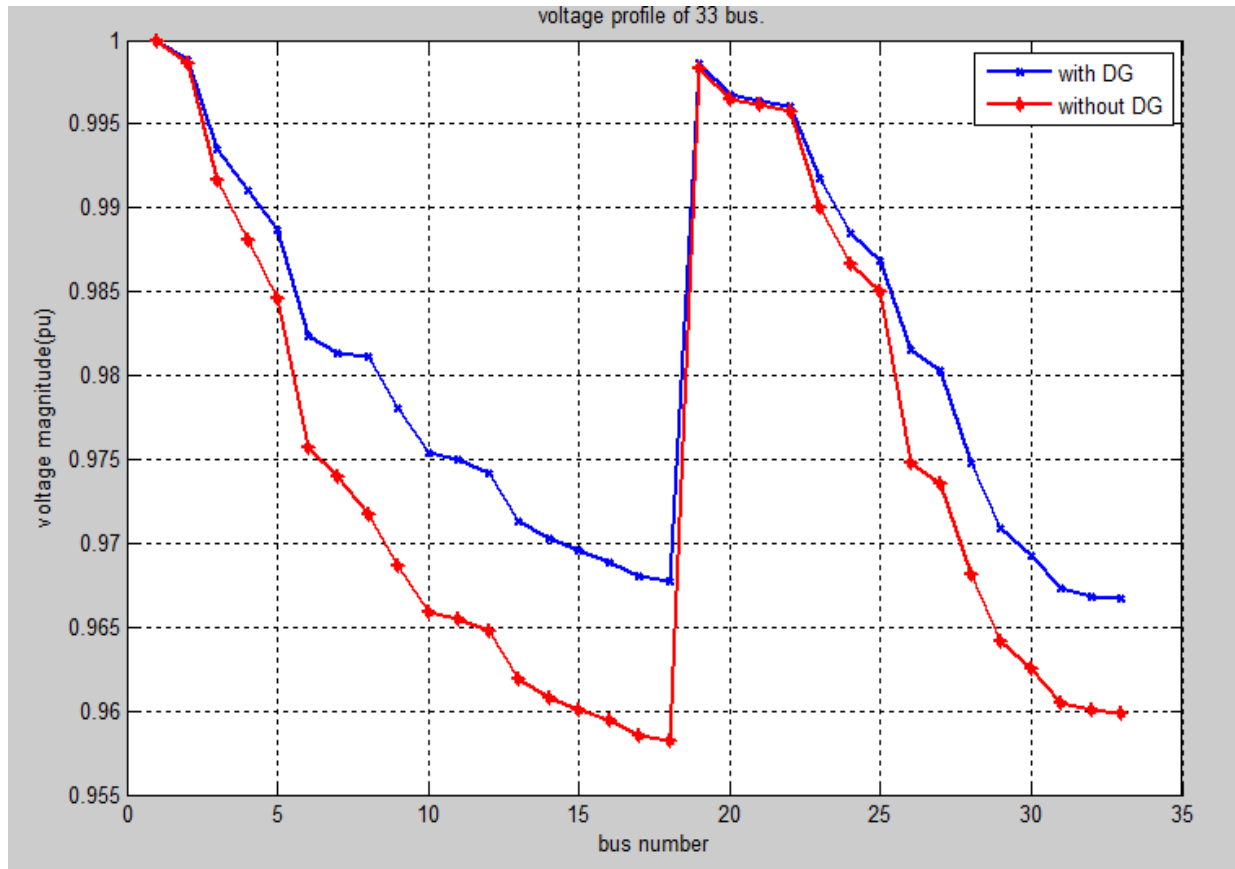

Figure5. 5 Voltage profile improvement at 50% of full load condition by analytical method

Case 3: at 150% of full load condition

In case of an over load condition or at 150% of full load condition, the optimal DG that has been found in analytical method is type 1, at bus 8 and 2.823MW location and size respectively. The real power loss reduced from 494.95KW to 269.99KW and reactive power loss 330.48KVAR to 195.84KVAR. The voltage profile improvement at 150% full load condition is shown in figure 5.6 and most bus voltages are above 0.95 pu.

Voltage Profile Improvement and Power Loss Minimization of Radial Distribution Feeders Using Optimal Allocation and Sizing of Distribution Generator (DG)

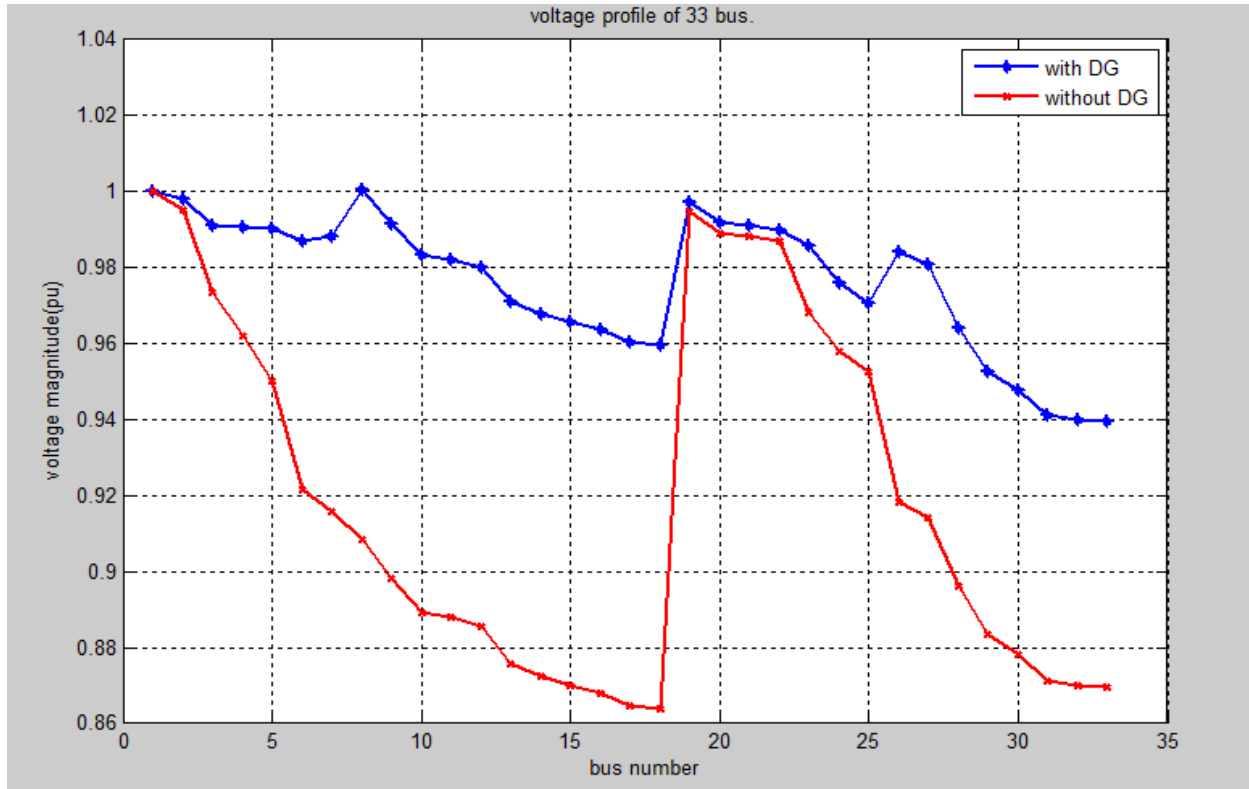

Figure5. 6 Voltage profile improvement in 150%full load condition by analytical method

The summary result by considering different cases for load variations for analytical method is given in table 5.3 below.

Table 5. 3 Summary result for analytical method

	Full load	50% full load	150% full load
Total real power loss without DG(kw)	202.69	47.17	494.95
Total reactive power loss without DG(kvar)	135.14	31.41	330.48
Min voltage without DG(pu)	0.9131@ 18	0.9582@ 18	0.8638@18
Optimal location	Bus 8	Bus 8	Bus 8
Optimal size(KW)	1880	941	2823
Total real power loss with DG(kw)	110.04	32.29	269.99
Total reactive power loss with DG(kvar)	75.75	21.50	195.84
Min voltage after optimization(pu)	0.9458@ 33	0.9667@ 33	0.9396@ 33
% real power loss reduction	45.71	41.17	45.45
% reactive power loss reduction	43.94	41.30	40.74

5.4. Result on optimal allocation and sizing of DG using loss sensitivity factor and PSO method

The result for optimal allocation of DG using loss sensitivity factor, bus 13 and 30 are the best location for DG to be placed. The proposed PSO algorithm for optimal sizing of DG for the three cases of load variations considered. The proposed algorithm was run for minimization of real power loss as the objective function described in eq. 4.47. The parameters used are

- Population size=30,
- $C1=C2=2$,
- $W_{max}=0.9, W_{min}=0.4$

Case 1: At full load condition

The optimal DG sizes obtained are 773.4 and 632.4KW at bus 13 and 30 respectively. The total real and reactive power loss with DG reduced from 202.69KW to 95.8KW and from 135.14KVAR to 64.1KVAR respectively. The voltage profile improvement is shown below in figure 5.7 and all bus voltages are within acceptable voltage limit

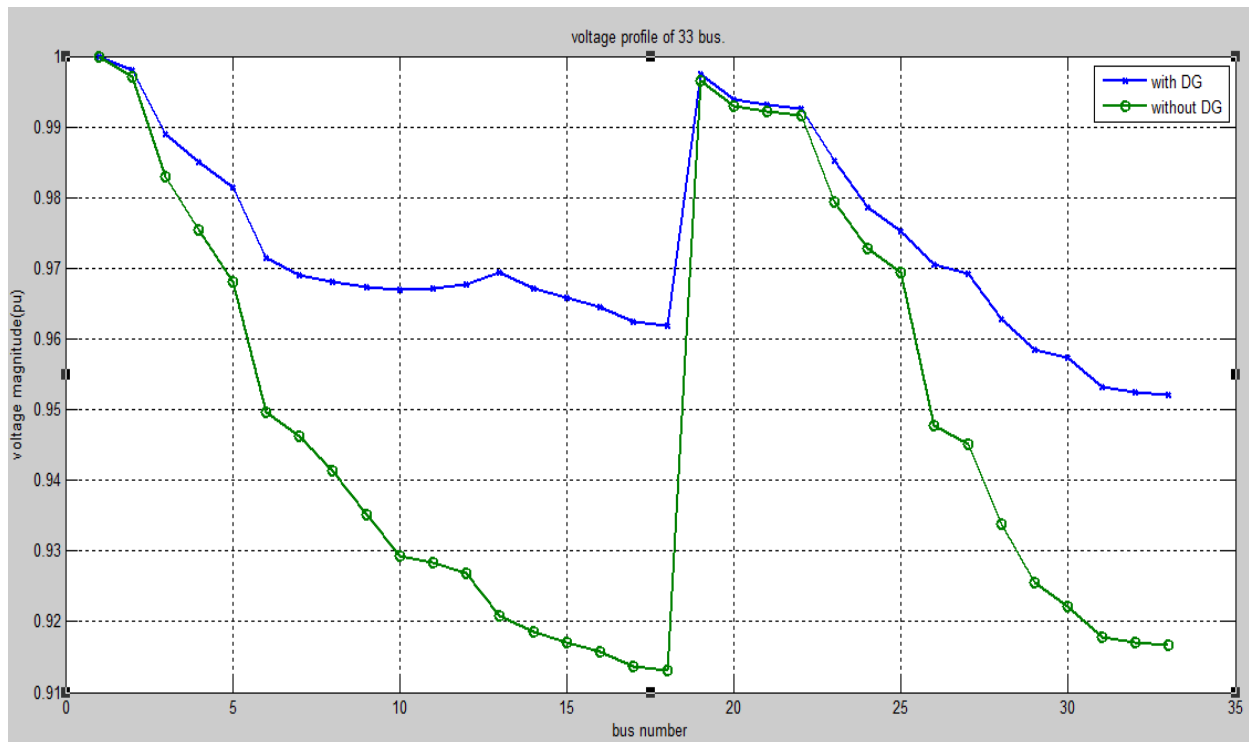

Figure5. 7 Voltage profile improvement at full load condition

Case 2: at 50% of full load condition

The optimal DGs size at 50% of full load condition is 723.4 and 287.8KW at bus 13 and 30 respectively. The reduction obtained in total real and reactive power loss from 47.17KW and 31.41KVAR to 27.7KW and 18.4KVAR., the voltage profile improvement for half of full load condition is given in figure 5.8 below

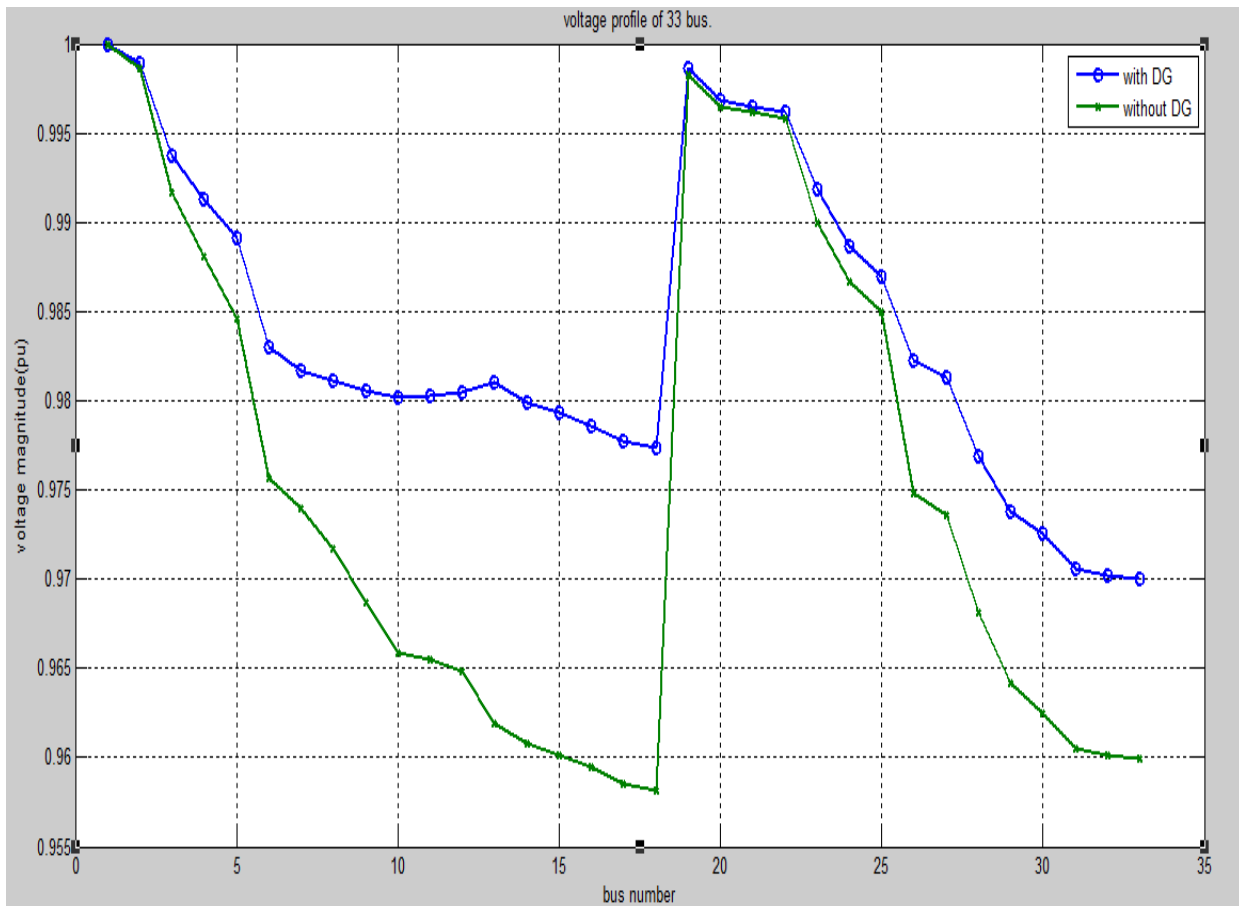

Figure5. 8 voltage profile improvement at 50%full load case by a PSO method

Case 3: at 150% of full load

In this case the optimal DG found to be at bus 13 is 712KW and 822KW at bus 30. The percentage total real and reactive power loss of at over load condition is found 57.55 and 57.21 respectively, which is far more good result than analytical method with best loss minimization using such small size of DG.

Voltage Profile Improvement and Power Loss Minimization of Radial Distribution Feeders Using Optimal Allocation and Sizing of Distribution Generator (DG)

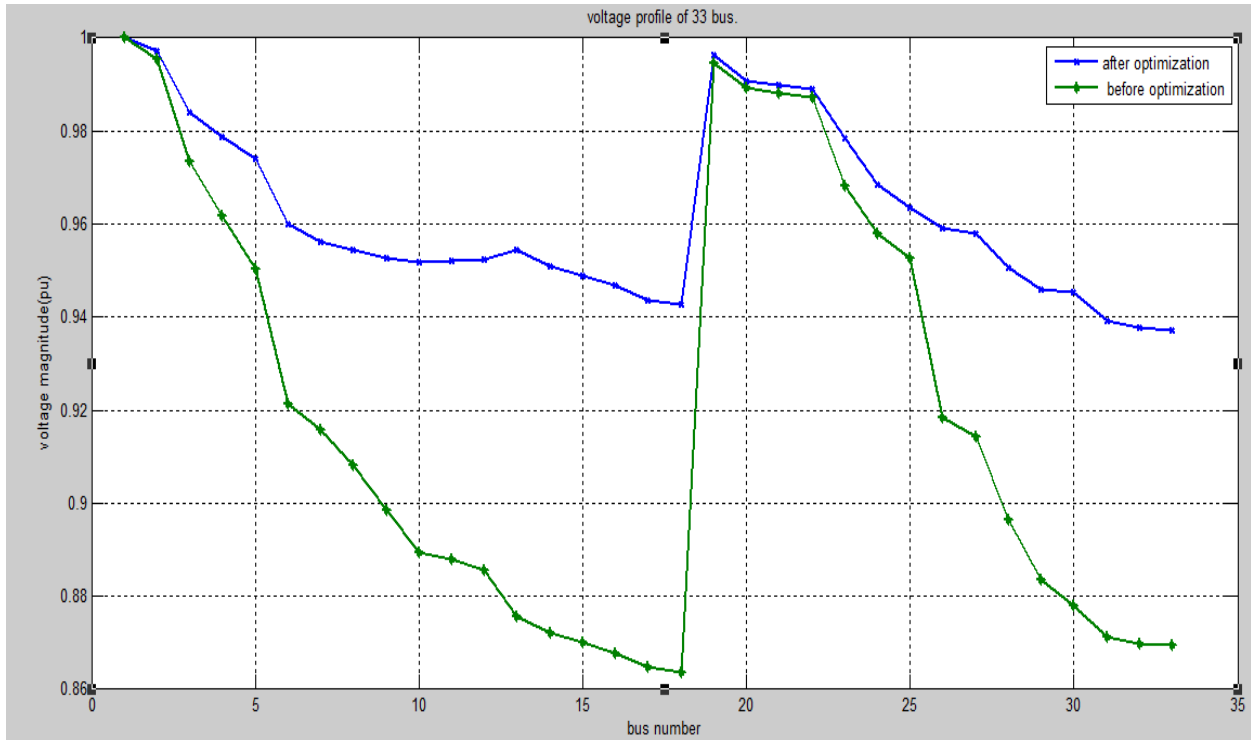

Figure5. 9 Voltage profile improvement at 150%full load case using PSO method

The result on summary of PSO algorithm for the three cases of load condition at optimal location of bus 13 and 30 with DGs of suitable size shown in table 5.4.

Table 5. 4 Summary of result for PSO method

	Full load	50% of full load	150% of full load
Total real power loss without DG (Kw)	202.69	47.17	494.95
Total reactive power loss without DG (KVar)	135.14	31.41	330.48
Min voltage without DG (pu)	0.9131@ 18	0.9582@ 18	0.8638@18
Optimal location	Bus 13,30	Bus 13,30	Bus 13,30
Optimal size(KW)	773.4, 632.4	723.4,287.8	712, 822
Total real power loss with DG (Kw)	95.8	27.7512	210.1
Total reactive power loss with DG (KVar)	64.1	18.41	141.4
Min voltage with DG (pu)	0.9521@ 33	0.9700@ 33	0.9372@ 33
% real loss reduction	52.73	41.17	57.55
% reactive loss reduction	52.56	41.30	57.21

Voltage Profile Improvement and Power Loss Minimization of Radial Distribution Feeders Using Optimal Allocation and Sizing of Distribution Generator (DG)

According to the above comparison between analytical and PSO methods, PSO has best results and is found to be better in terms of loss minimization and voltage profile improvement. Hence, this method is applied for the case study of Jimma Distribution feeders.

5.5. Case Study and Data Analysis

5.5.1. Description of the study area

In this thesis work, Jimma city old electric power distribution substation is selected for the case study. The distribution substation is located at latitude of $7^{\circ} 40' 22.1''$ N and longitude of $36^{\circ} 50' 32.9''$ E. Jimma city which is located to south-western Ethiopia, is 354 km far from the capital city Addis Ababa, with an area of about 50.52 km^2 with an elevation of 1780 meters above sea level. According to [28] report, the population of Jimma city is 207, 000. The geographical map of the city is shown below.



Figure5. 10 Map of Jimma city

5.5.2. Jimma Distribution Substation

Jimma substation was installed by 1979 E.C, equipped with three phase transformers with rating of 6.5 MVA. However, in 1997 E.C, the power transformer is upgraded to 20MVA, 132/15kv and another 16MVA, 132/33kv was added in the substation.

Voltage Profile Improvement and Power Loss Minimization of Radial Distribution Feeders Using Optimal Allocation and Sizing of Distribution Generator (DG)

Jimma old substation supplies electric power to Jimma city and additional nearby areas. 132kv power lines are fed from Gilgel Gibe I & II power plants to the substation. Using three phase transformers this 132kv is stepped down and distributed by five 15kv feeders and two 33kv feeders, with total of 7 outgoing feeders.

The 15kv feeders consisted up of five feeders which includes; City feeder, Kochi feeder, Agriculture feeder, Jimma University feeder and Kitto Furdisa feeder. On the other hand, 33kv feeders consisted up of two feeders which includes Shebe Sembo and Limu Genet.



Figure5. 11 Partial view for Jimma substation

Among the 15kv feeders, Agriculture feeder is selected for the case study which deliver power to agriculture campus and nearby customers. The main reason to select this feeder as case study site is, all necessary data access is found in agriculture feeder compared to other feeders and in this line frequent power interruption is observed as per the information found from the EEP personnel's.

5.5.3. Radial Distribution of the selected Feeder

The radial configuration of agriculture feeder consists of 39–lines and 40 buses, out of this node 1 is taken as a slack bus or reference node. The other 39 branch nodes are connected to loads through step-down distribution transformers.

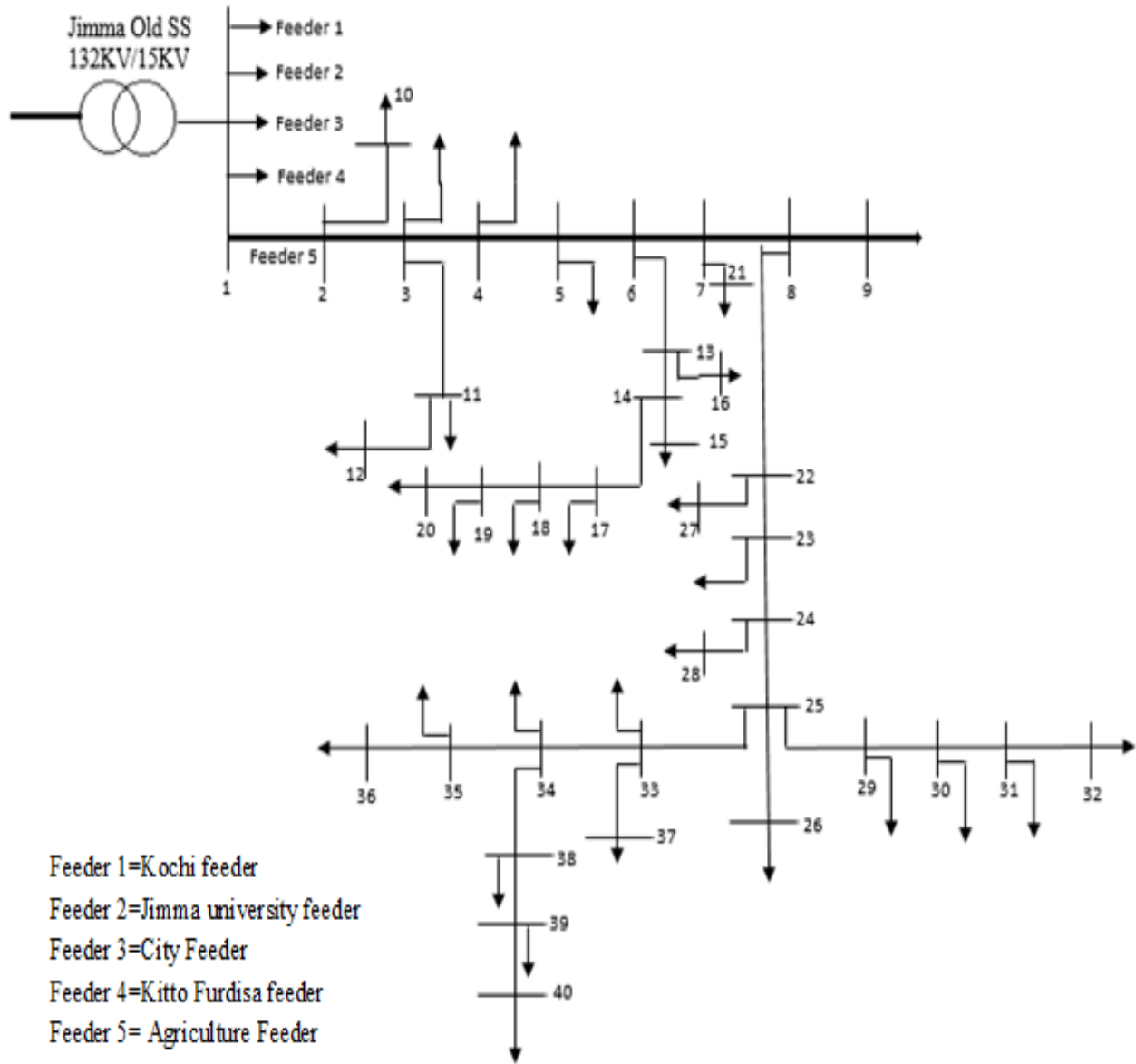

Figure5. 12 Single line diagrams of 40 buses of agriculture feeder

The load flow analysis using forward/backward load flow analysis method is done by using line and load data given in table 5.5. After load flow analysis optimal allocation and sizing of DG for agriculture feeder is performed by using loss sensitivity factor and PSO methods.

Voltage Profile Improvement and Power Loss Minimization of Radial Distribution Feeders Using Optimal Allocation and Sizing of Distribution Generator (DG)

The data's tabulated below (line, load and other related data) of the selected feeder is total load of 3.25MW and 2.74MVar and collected from EEP office of Jimma city and Jimma distribution substation personnel's.

Table 5. 5 Line and load data of agriculture feeder

Line no	From bus	To bus	Resistance (ohm)	Reactance (ohm)	Real power (kw)	Reactive power (kvar)
1.	1	2	0.3471	0.2082	0	0
2.	2	3	0.1446	0.0867	10	6.7
3.	3	4	0.1446	0.0867	59.3	42.26
4.	4	5	0.1157	0.0694	75.7	50.59
5.	5	6	0.0867	0.0520	86	69
6.	6	7	0.2314	0.1388	64	59
7.	7	8	0.2314	0.1388	57	30
8.	8	9	0.0578	0.0347	38	28.5
9.	2	10	0.1157	0.0694	146.7	124.08
10.	3	11	0.1157	0.0694	71.71	71.11
11.	11	12	0.0867	0.052	136.7	103.84
12.	6	13	0.2314	0.1388	70	80
13.	13	14	0.0867	0.052	60	55
14.	14	15	0.2603	0.1561	53.9	44.65
15.	13	16	0.1735	0.1041	65.5	54.22
16.	14	17	0.0289	0.0173	70.4	52.8
17.	17	18	0.0289	0.0173	132	121.8
18.	18	19	0.0578	0.0347	78.28	66.93
19.	19	20	0.0578	0.0347	80.8	50.63

Voltage Profile Improvement and Power Loss Minimization of Radial Distribution Feeders Using Optimal Allocation and Sizing of Distribution Generator (DG)

20.	7	21	0.0578	0.0347	159.75	158.43
21.	8	22	0.0867	0.052	67.9	47.6
22.	22	23	0.0867	0.052	75.07	62.2
23.	23	24	0.3471	0.2082	98.5	39.67
24.	24	25	0.2314	0.1388	78.56	88.8
25.	25	26	0.0289	0.0173	87.22	92.02
26.	22	27	0.1735	0.1041	113	96.82
27.	24	28	0.1735	0.1041	45.6	38.99
28.	25	29	0.1446	0.0867	118.04	112.6
29.	29	30	0.1446	0.0867	45.81	38
30.	30	31	0.0867	0.052	64.6	55
31.	31	32	0.0867	0.052	86.52	74.54
32.	25	33	0.3471	0.2082	98.4	53.8
33.	33	34	0.1735	0.1041	128.3	115.58
34.	34	35	0.2314	0.1388	124.45	117.37
35.	35	36	0.1146	0.0867	57.75	48.74
36.	33	37	0.0578	0.0347	82.3	78.58
37.	34	38	0.1735	0.1041	68.5	47.8
38.	38	39	0.1446	0.0867	88	66
39.	39	40	0.0144	0.0086	93.5	86
40.					115	110

The result on load flow analysis for agriculture feeder using backward/forward sweep load flow analysis is found to be total real and reactive power loss of 94KW and 56KVAR respectively. Then using PSO and loss sensitivity factor method, optimized DG allocation in bus 26 and 40 is found with optimal size of 782 KW and 474KW respectively.

Voltage Profile Improvement and Power Loss Minimization of Radial Distribution Feeders Using Optimal Allocation and Sizing of Distribution Generator (DG)

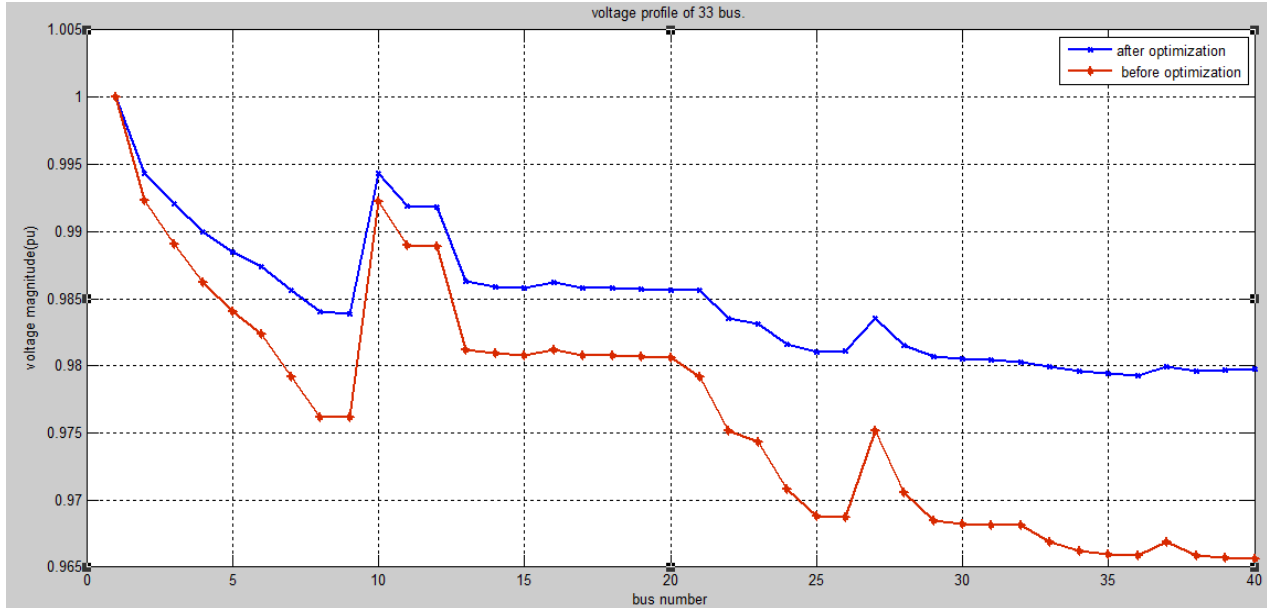

Figure5. 13 Voltage profile improvement for agriculture feeder.

The optimization of agriculture feeder using DG units at optimal location on bus 26 and 40, with optimal size of 782 and 474 KW respectively, results in voltage profile improvement as shown in fig. 5.13 and total real and reactive power loss minimization with percentage value of 43.6 and 42.8 as shown in table5.6.

Table 5. 6 Result summary of agriculture feeder

Total real power loss without DG (KW)	94
Total reactive power loss without DG (KVar)	56
Min voltage without DG (pu)	0.9656@ 40
Optimal location	Bus 26,40
Optimal size(KW)	782, 474
Total real power loss with DG (KW)	53
Total reactive power loss after with DG (KVar)	32
Min voltage with DG (pu)	0.9793@ 36
% real loss reduction	43.6
% reactive loss reduction	42.8

5.6. Economic analysis for optimal size of DG Units

5.6.1. Optimization result using HOMER software

Optimal size of DG is initially obtained by using PSO method and given to HOMER for economic analysis of DG units installation in distribution feeder under the case study. Using the solar and temperature resources (Appendix B) of Jimma city old distribution substation, all feasible optimization solutions of the proposed system is analyzed using HOMER PRO. The schematic diagram for the design include the grid in the ac bus side and solar photovoltaic at dc bus side, converter for converting DC power of solar photovoltaic to AC. Solar photovoltaic (PV) systems together with batteries are used to supply the load when power from the grid is insufficient.

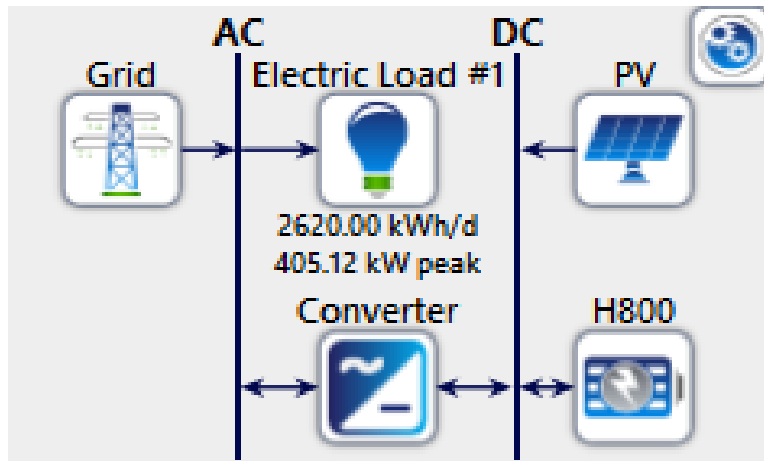

Figure5. 14 Schematic diagram of the system design

Based on the net present cost (NPC) and cost of energy optimization results of HOMER PRO, the list of best combinations is shown in table 5.7 below.

Table 5. 7 HOMER optimization result

Possible combinations of technologies	NPC (\$)	COE (\$)
Grid (EC 0.09), PV (1.2 MW)	607,282.80	0.07192
Grid (EC 0.09), PV (1. 2MW), convertor (1 MW), Battery (H800)	608,024,40	0.07201
Grid (EC 0.09)	675,035.40	0.09
Grid (EC 0.09), Battery (H800), convertor (1 MW)	675,777.10	0.0901

Analysis of operation and maintenance costs, and also salvage cost of the overall system is accomplished by the software.

5.6.2. Economic analysis using cost of energy losses (CL)

The cost of energy losses is given using equation below

$$CL = \text{total power loss} * T * E$$

E = energy rate (\$/kWh)

T = time duration (h)

Where, E = 0.09 \$/kWh (based on approximation of EEP energy sell) and T = 8760 h

The cost of energy loss before (without DG) and after minimization (with DG) of loss using PSO method at full load condition is given as,

$$\begin{aligned} CL_{\text{without DG}} &= 94 \text{ kW} * 8760 \text{ h} * 0.09 \text{ \$/kWh} \\ &= 74,109.6 \$ \end{aligned}$$

$$\begin{aligned} CL_{\text{with DG}} &= 53 \text{ kW} * 8760 \text{ h} * 0.09 \text{ \$/kWh} \\ &= 41,785.2 \$ \end{aligned}$$

$$\begin{aligned} \text{Savings of CL} &= CL_{\text{without DG}} - CL_{\text{with DG}} \\ &= 32,324.4 \$ \end{aligned}$$

CHAPTER SIX

6. CONCLUSION AND RECOMMENDATION

6.1. Conclusion

In this thesis the minimization of power loss and voltage profile improvement in radial distribution system has been achieved by using an optimal type, size and location of distribution generator. The methods that are used in optimization of DG are analytical method and particle swarm optimization (PSO) with loss sensitivity factor analysis method. Forward backward sweep load flow analysis method used and the voltage and power loss level of each bus bar in IEEE 33 bus system with three load variation cases have been determined. The PSO method with loss sensitivity factor in type-1 DG provides optimal size and location of DG with best loss minimization and improved voltage profile result than that of analytical method. The optimal locations of DG found to be bus 13 and 30 with optimal size of 773.4 KW and 632.4 KW at full load condition. The voltage magnitudes in all buses are within acceptable limit ± 0.05 pu and power loss is minimized to acceptable limit as compared to previous research outputs. After analysis of the two computational methods, the best efficient method is applied for the case study of Jimma distribution feeder. Then using PSO and loss sensitivity factor the optimal location of bus 26 and 40 with optimal size of 782 KW and 474KW obtained. The percentage reduction of loss was 43.6% and 42.8% in real and reactive power loss respectively with good voltage profile improvement. Accordingly, economic analysis of the proposed system using HOMER also results in an optimal combination of technologies depending on NPC and COE of the system. The economic issues associated with the DG unit installation: such as cost of energy losses (CL) with and without DG unit have been compared and total saving of 32,324.4 \$ is found. Finally based on the results found it is possible to say that the proposed methodology is efficient in minimization of power loss and improvement of voltage profile for feeders on the side of consumers.

6.2. Recommendation

Despite of all the benefits of DG that provide to the distribution system the non-optimized sizing and allocation of DG result in increasing loss and high voltage fluctuation. Even though there has been usage of DG in different parts, there are factors that affect the implementation of optimal DG in different existing practical systems. Therefore, real time and experimental data can further be used as an input to process and make a decision for optimal sizing and allocation of DG. Hence, data collection from existing SCADA system is required and amount of installation cost need to be considered. Furthermore, researches can be done by using optimization of DG with feeder reconfiguration and capacitor placement, so that cost issues could be minimized.

REFERENCES

- [1] A. Hasibuan, S. Masri, B. Othman, “Effect of distributed generation installation on power loss using genetic algorithm method”, 10th International Conference Numerical Analysis in Engineering, 2018.
- [2] L. Ioan, M. Abrudean, D. Bică, “Optimal Location of a Distributed Generator for Power Losses Improvement”, 9th International Conference Interdisciplinary in Engineering, INTER-ENG 2015, 8-9 October 2015.
- [3] International Energy Agency IEA, World Energy Statistical analysis, 2012.
- [4] V. Vita.; T. Alimardan, L. Ekonomou, “The impact of distributed generation in the distribution networks’ voltage profile and energy losses”. 9th IEEE European Modeling Symposium on Mathematical modeling and Computer Simulation, Madrid, Spain, 6–8 October 2015.
- [5] V. Vita “Development of a Decision-Making Algorithm for the Optimum Size and Placement of Distributed Generation Units in Distribution Networks”, 18 September 2017.
- [6] A.Marneni , A.D.Kulkarni, T.Anan “Loss Reduction and Voltage Profile Improvement in a Rural Distribution Feeder using Solar Photovoltaic Generation and Rural Distribution Feeder Optimization using HOMER”, August 6-8, 2015.
- [7] S.Essallah, A. Bouallegue and A. Khedher, “Optimal Sizing and Placement of DG Units in Radial Distribution System”, international journal of renewable energy research, Vol.8, No.1, March, 2018.
- [8] A.M. El-Zonkoly, “Optimal placement of multi-distributed generation units including different load models using particle swarm optimization”, *IET Gener. Transm. Distrib.*, Vol. 5, Iss. 7, 2011, pp.760–771.
- [9] C. Wang, M. H. Nehrir, “Analytical Approaches for Optimal Placement of DG Sources in Power Systems”, IEEE transaction on power system, Vol. 19, No. 4, Nov 2004, pp. 2068–2076.
- [10] D.Q. Hung, N. Mithulanathan and R.C. Bansal, “Multiple Distributed Generators Placement in Primary Distribution Networks for Loss Reduction,” IEEE Trans. on Industrial Electronics, Vol. 57, Issue No. 4, 2011.
- [11] D. Gautam and N. Mithulanathan, “Optimal DG placement in deregulated electricity market”, Electric Power Systems Research, Volume 77, 2006, pp. 1627–1636.
- [12] Meysam Kalantari and Ahad Kazemi, “Placement of Distributed Generation unit and Capacitor Allocation in Distribution Systems using Genetic Algorithm”, 10th International Conference on Environment and Electrical Engineering (EEEIC), 2011.
- [13] M. Damodar Reddy and V. C. Veera Reddy, “Capacitor Placement Using Fuzzy and Particle Swarm Optimization Method for Maximum Annual Savings”, Vol. 3, No. 3, June 2008.
- [14] Electrical4u.com, Electrical Power Distribution System, Radial and Ring Main, 2014.
<https://www.electrical4u.com/electrical-power-distribution-system-radial-ring-main-electrical-power-distribution-system/>

- [15] RDC, resource Dynamics Corporation, Assessment of Distributed Generation Technology Applications, Maine Public Utilities Commission, 2001.
- [16] Thong, V. V. and Belmans, R., 2006, "Distributed Generation Overview: Current Status and Challenges," International Review of Electrical Engineering, vol. 1, pp. 178-189.
- [17] W. El-Khattam, M.M.A Salama, "Distributed generation technologies, definitions and benefits," Electric power systems research, vol. 71, 2004, pp. 119-128.
- [18] P.S. Georgilakis, N.D. Hatzargyriou, "Optimal distributed generation placement in power distribution networks: Models, methods, and future research," IEEE Transactions on Power Systems, Vol. 28, No. 3, Aug. 2013, pp. 3420 – 3428.
- [19] Ray Daniel Zimmerman, "Comprehensive distribution power flow: modeling, formulation, solution algorithms and analysis", Cornell University, 1995.
- [20] B. Stott and O. Alsac, "Fast Decoupled Load-Flow," IEEE Trans. power apparatus and systems, vol. PAS-93,1974, pp. 859–869.
- [21] J. Kennedy and R. Eberhart, "Particle Swarm Optimization," Proceedings of the 1995 IEEE Neural Networks Conference, IEEE Service Center, Piscataway, NJ, pp. 1942-1948.
- [22] A. Carlisle and G. Dozier, "An Off-The-Shelf PSO," in Workshop Particle Swarm Optimization, Indianapolis, 2001.
- [23] A. P. Engelbrecht, 'Computational Intelligence: An introduction', John Wiley and Sons, 2007, ch. 16, pp. 289-358.
- [24] S. abrol and M. kaur, A review on Particle Swarm Optimization Technique, Vol. 3, Issue 7, July 2016.
- [25] B.Roy, A.Kumar, S. Paul, "Optimal design of a grid connected solar photovoltaic power system for a residential load."
- [26] Paulo M. De Oliveira-De Jesus, "The Standard Backward/Forward Sweep Power Flow", 2008.
- [27] P. Kumara, R. Pukaleb ,N. Kumabharc,U. Patild,' Optimal Design Configuration Using HOMER', International Conference on Emerging Trends in Engineering, Science and Technology (ICETEST - 2015)
- [28] <https://www.ethiovisit.com/oromia>, Oromia Region Major Cities and Population, 2013.

APPENDIX A

Line data and bus data of IEEE standard 33 bus system

bus number	From bus	To bus	Resistance in pu	Reactance in pu	Real power in pu	Reactive power in pu
1.	1.	2	0.0575	0.0293	0	0
2.	2.	3	0.3076	0.1567	0.0010	0.0006
3.	3.	4	0.2284	0.1163	0.0009	0.0004
4.	4.	5	0.2378	0.1211	0.0012	0.0008
5.	5.	6	0.5110	0.4411	0.0006	0.0003
6.	6.	7	0.1168	0.3861	0.0006	0.0002
7.	7.	8	0.4439	0.1467	0.0020	0.0010
8.	8.	9	0.6426	0.4617	0.0020	0.0010
9.	9.	10	0.6514	0.4617	0.0006	0.0002
10.	10.	11	0.1227	0.0406	0.0006	0.0002
11.	11.	12	0.2336	0.0772	0.0004	0.0003
12.	12.	13	0.9159	0.7206	0.0006	0.0004
13.	13.	14	0.3379	0.4448	0.0006	0.0004
14.	14.	15	0.3687	0.3282	0.0012	0.0008
15.	15.	16	0.4656	0.3400	0.0006	0.0001
16.	16.	17	0.8042	1.0738	0.0006	0.0002
17.	17.	18	0.4567	0.3581	0.0006	0.0002
18.	2	19	0.1023	0.0976	0.0009	0.0004
19.	19	20	0.9385	0.8457	0.0009	0.0004
20.	20	21	0.2555	0.2985	0.0009	0.0004

Voltage Profile Improvement and Power Loss Minimization of Radial Distribution Feeders Using Optimal Allocation and Sizing of Distribution Generator (DG)

21.	21	22	0.4423	0.5848	0.0009	0.0004
22.	3	23	0.2815	0.1924	0.0009	0.0004
23.	23	24	0.5603	0.4424	0.0009	0.0005
24.	24	25	0.5590	0.4374	0.0042	0.0020
25.	6	26	0.1267	0.0645	0.0042	0.0020
26.	26	27	0.1773	0.0903	0.0006	0.0003
27.	27	28	0.6607	0.5826	0.0006	0.0003
28.	28	29	0.5018	0.4371	0.0006	0.0002
29.	29	30	0.3166	0.1613	0.0012	0.0007
30.	30	31	0.6080	0.6008	0.0020	0.0060
31.	31	32	0.1937	0.2258	0.0015	0.0007
32.	32	33	0.2128	0.3308	0.0021	0.0010
33.					0.0006	0.0004

APPENDIX B

PV Resource data(solar GHI) & Temperature of Jimma city for HOMER PRO software

month	Clearness index	Daily radiation(Kwh/m ² /day)	Temperature(⁰ C)
January	0.591	5.43	21.22
February	0.595	5.82	22.24
March	0.569	5.87	22.03
April	0.539	5.64	20.46
may	0.525	5.39	19.16
June	0.484	4.87	18.43
July	0.436	4.41	17.71
august	0.449	4.64	17.86
September	0.505	5.21	18.29
October	0.545	5.39	18.44
November	0.582	5.40	18.88
December	0.604	5.41	19.95

APPENDIX C

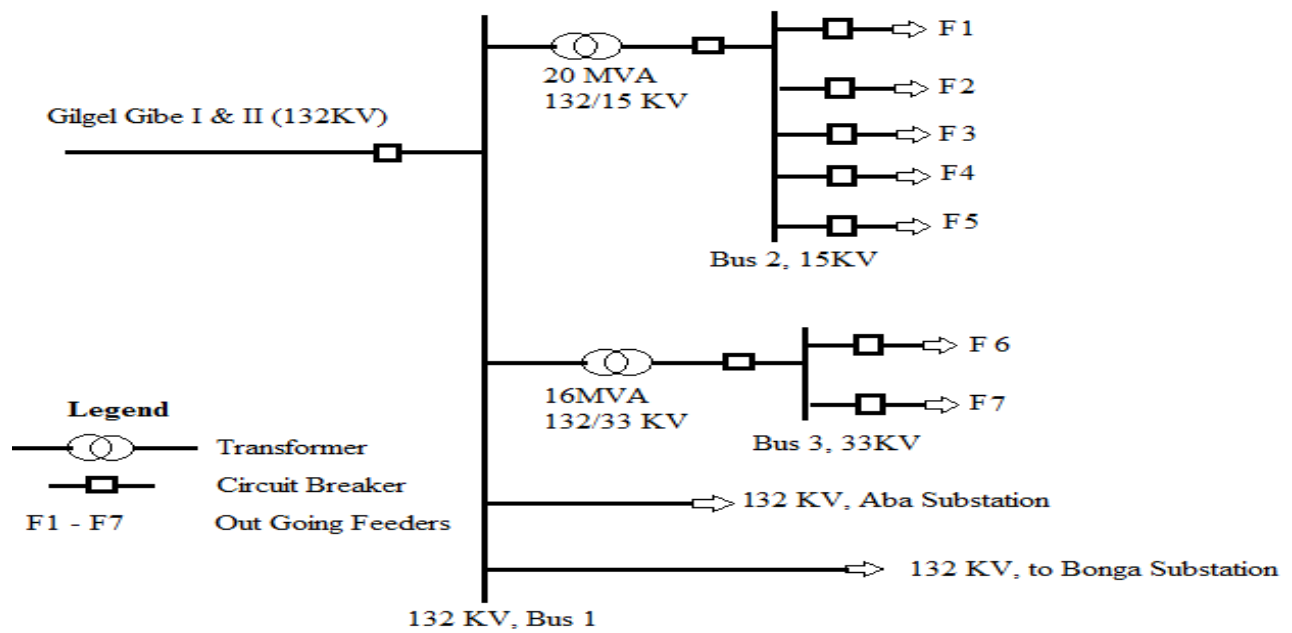

Figure. C-1: Schematic Diagram of Jimma old substation outgoing feeders

APPENDIX D

Matlab Code for load flow analysis of Agriculture feeder using FBS method

```
clc;
clear all;
format short;
tic

m=load('m.m');
l=load('b.m');

br=length(l);
no=length(m);

MVA=100;
KV=15;

Zb=(KV^2)/MVA;
% Per unit Values
for i=1:br
    R(i,1)=(l(i,4))/Zb;
    X(i,1)=(l(i,5))/Zb;
end
for i=1:no
    P(i,1)=(m(i,2))/(1000*MVA);
    Q(i,1)=(m(i,3))/(1000*MVA);
end
R
X
P
Q
C=zeros(br,no);
for i=1:br
    a=l(i,2);
    b=l(i,3);
    for j=1:no
        if a==j
            C(i,j)=-1;
        end
        if b==j
            C(i,j)=1;
        end
    end
end
end
C
e=1;
for i=1:no
    d=0;
    for j=1:br
        if C(j,i)==-1
            d=1;
        end
    end
    if d==0
        endnode(e,1)=i;
    end
end
```

Voltage Profile Improvement and Power Loss Minimization of Radial Distribution Feeders Using Optimal Allocation and Sizing of Distribution Generator (DG)

```
        e=e+1;
    end
end
endnode
h=length(endnode);
for j=1:h
    e=2;

    f=endnode(j,1);
    % while (f~=1)
    for s=1:no
        if (f~=1)
            k=1;
            for i=1:br
                if ((C(i,f)==1) && (k==1))
                    f=i;
                    k=2;
                end
            end
            k=1;
            for i=1:no
                if ((C(f,i)==-1) && (k==1));
                    f=i;
                    g(j,e)=i;
                    e=e+1;
                    k=3;
                end
            end
        end
    end
end
end
end
end
for i=1:h
    g(i,1)=endnode(i,1);
end
g;
w=length(g(1,:))
for i=1:h
    j=1;
    for k=1:no
        for t=1:w
            if g(i,t)==k
                g(i,t)=g(i,j);
                g(i,j)=k;
                j=j+1;
            end
        end
    end
end
end
g;
for k=1:br
    e=1;
    for i=1:h
        for j=1:w-1
            if (g(i,j)==k)
                if g(i,j+1)~=0
                    adjb(k,e)=g(i,j+1);
                    e=e+1;
                end
            end
        end
    end
end
end
```

Voltage Profile Improvement and Power Loss Minimization of Radial Distribution Feeders Using Optimal Allocation and Sizing of Distribution Generator (DG)

```
                else
                    adjb(k,1)=0;
                end
            end
        end
    end
end
adjb;
for i=1:br-1
    for j=h:-1:1
        for k=j:-1:2
            if adjb(i,j)==adjb(i,k-1)
                adjb(i,j)=0;
            end
        end
    end
end
adjb;
x=length(adjb(:,1));
ab=length(adjb(1,:));
for i=1:x
    for j=1:ab
        if adjb(i,j)==0 && j~=ab
            if adjb(i,j+1)~=0
                adjb(i,j)=adjb(i,j+1);
                adjb(i,j+1)=0;
            end
        end
        if adjb(i,j)~=0
            adjb(i,j)=adjb(i,j)-1;
        end
    end
end
adjb;
for i=1:x-1
    for j=1:ab
        adjcb(i,j)=adjb(i+1,j);
    end
end
b=length(adjcb);

% voltage current program

for i=1:no
    vb(i,1)=1;
end
for s=1:10
for i=1:no
    nlc(i,1)=conj(complex(P(i,1),Q(i,1)))/(vb(i,1));
end
nlc;
for i=1:br
    Ibr(i,1)=nlc(i+1,1);
end
Ibr;
xy=length(adjcb(1,:));
```

Voltage Profile Improvement and Power Loss Minimization of Radial Distribution Feeders Using Optimal Allocation and Sizing of Distribution Generator (DG)

```
for i=br-1:-1:1
    for k=1:xy
        if adjcb(i,k)~=0
            u=adjcb(i,k);
            Ibr(i,1)=Ibr(i,1)+Ibr(u,1);
        end
    end
end
Ibr;
for i=2:no
    g=0;
    for a=1:b
        if xy>1
            if adjcb(a,2)==i-1
                u=adjcb(a,1);
                vb(i,1)=(vb(u,1))-((Ibr(i-1,1))*(complex((R(i-1,1)),X(i-
1,1)))));
                g=1;
            end
            if adjcb(a,3)==i-1
                u=adjcb(a,1);
                vb(i,1)=(vb(u,1))-((Ibr(i-1,1))*(complex((R(i-1,1)),X(i-
1,1)))));
                g=1;
            end
        end
    end
    if g==0
        vb(i,1)=(vb(i-1,1))-((Ibr(i-1,1))*(complex((R(i-1,1)),X(i-
1,1)))));
    end
end
s=s+1;
end
nlc;
Ibr;
vb
vbp=[abs(vb) angle(vb)*180/pi]

toc;
for i=1:no
    va(i,2:3)=vbp(i,1:2);
end
for i=1:no
    va(i,1)=i;
end
va;

Ibrp=[abs(Ibr) angle(Ibr)*180/pi];
PL(1,1)=0;
QL(1,1)=0;

% losses
for f=1:br
    Pl(f,1)=(Ibrp(f,1)^2)*R(f,1);
end
```

Voltage Profile Improvement and Power Loss Minimization of Radial Distribution Feeders Using Optimal Allocation and Sizing of Distribution Generator (DG)

```
    Ql(f,1)=X(f,1)*(Ibrp(f,1)^2);
    PL(1,1)=PL(1,1)+Pl(f,1);
    QL(1,1)=QL(1,1)+Ql(f,1);
end

Plosskw=(Pl)*100000
Qlosskvar=(Ql)*100000
PL=(PL)*100000
QL=(QL)*100000

voltage = vbp(:,1)
angle = vbp(:,2)*(pi/180)

% PSO code for sizing of DG

i=1;
S1=0.2777*ones(40,1)+(0.8329-0.2777)*rand(40,1);%sizing
S2=0.2777*ones(40,1)+(0.8329-0.2777)*rand(40,1);%sizing
L1=26*ones(40,1);%location
L2=40*ones(40,1);%location
X=[S1 S2 L1 L2];
d=4;
pop=40;
wmax=0.9;
wmin=0.4;
imax=200;
c1=2;
c2=2;
Vi=rand(pop,d);
pb=X;
worsts = zeros(40, 1);
bests = zeros(40, 1);
meanfits = zeros(40, 1);
pb1=PL;
pb2=voltage;
M=PL;
N=voltage;
[p_g I]=min(M);
gb1=X(I,:);
gb2=X(I,:);
for i=1:imax
    w=wmax-((wmax-wmin)/imax)*i;
    for h=1:2
        for j=1:pop

            Vi(j,h)=w.* Vi(j,h)+c1*rand*(pb(j,h)-X(j,h))+c2*rand*(gb1(1,h)-X(j,h));
            X(j,h)=X(j,h)+Vi(j,h);
            Vi(j,h)=w.* Vi(j,h)+c1*rand*(pb(j,h)-X(j,h))+c2*rand*(gb2(1,h)-X(j,h));
            X(j,h)=X(j,h)+Vi(j,h);
        end
    end
end
```

Voltage Profile Improvement and Power Loss Minimization of Radial Distribution Feeders Using Optimal Allocation and Sizing of Distribution Generator (DG)

```
M1=PL;
N1=voltage;
[p_g1 ,I1]=min(M1);
if M1<M && 0.95<=N1<=1.05;
    pb=X;
end
if p_g1<=p_g;
    p_g=p_g1;
    gb1=X(I1, :);

end
worsts(i) = max(M1);
bests(i) = p_g;
meanfits(i) = mean(M1);

end
gb1
toc
```