

**JIMMA UNIVERSITY**

**SCHOOL OF GRADUATE STUDIES**

**JIMMA INSTITUTE OF TECHNOLOGY**

**FACULTY OF CIVIL AND ENVIRONMENTAL ENGINEERING**

**STRUCTURAL ENGINEERING STREAM**

**Comparative Study on the Efficiency of Retrofitting Reinforced Concrete Columns by  
Concrete, Steel, and Fiber Reinforced Polymer Jacketing**

A Research Submitted to the School of Graduate Studies of Jimma University in Partial  
Fulfillment of the Requirements for the Degree of Masters of Science in Structural Engineering

By: Samrawit Girma

April 2023

Jimma, Ethiopia

**JIMMA UNIVERSITY**

**SCHOOL OF GRADUATE STUDIES**

**JIMMA INSTITUTE OF TECHNOLOGY**

**FACULTY OF CIVIL AND ENVIRONMENTAL ENGINEERING**

**STRUCTURAL ENGINEERING STREAM**

**Comparative Study on the Efficiency of Retrofitting Reinforced Concrete Columns by  
Concrete, Steel, and Fiber Reinforced Polymer Jacketing**

A Research Submitted to the School of Graduate Studies of Jimma University in Partial  
Fulfillment of the Requirements for the Degree of Masters of Science in Structural Engineering

By: Samrawit Girma

Advisor: Dr. Kabtamu Getachew (Ph.D.)

Co-advisor: Eng. Besukal Befekadu (Msc)

April 2023

Jimma, Ethiopia

## DECLARATION

I declare that this thesis entitled “**Comparative Study on the Efficiency of Retrofitting Reinforced Concrete Column by Concrete, Steel and Fiber Reinforced Polymer Jacketing**” is my original work, and has not been presented by any other person for an award of a degree in this or any other University.

Samrawit Girma

\_\_\_\_\_

\_\_\_\_\_

Researcher

Signature

Date

Dr. Kabtamu Getachew (Ph.D.)

\_\_\_\_\_

\_\_\_\_\_

Advisor

Signature

Date

Engr. Besukal Befekadu (Msc)

\_\_\_\_\_

\_\_\_\_\_

(Co-advisor)

Signature

Date

## APPROVAL SHEET

This thesis has been submitted for examination as university supervisor. The thesis titled **“Comparative Study on the Efficiency of Retrofitting Reinforced Concrete Column by Concrete, Steel and Fiber Reinforced Polymer Jacketing** “by Samrawit Girma is approved for the Degree of Masters of Science in Structural Engineering.

### Approved by board of examiner:

We, the undersigned, approve the master’s thesis of Samrawit Girma.

Name	Signature	Date
Dr. Kabtamu Getachew (Ph.D.) (Advisor)	_____	_____
Engr. Besukal Befekadu (Msc) (Co-advisor)	_____	_____
Engr. Ashagre Fetene(Msc.) (Internal Examiner)	_____	_____
Dr. Biniya Patnalk (PhD) (External Examiner)	 _____	<u>10/4/23</u>
Engr. Abinet Alemseged(Msc.) (Chairperson)	_____	_____
Engr. Abinet Alemseged(Msc.) (Structural Engineering Chair)	_____	_____

## **ABSTRACT**

*Structural members experience strength deficiencies for a variety of reasons, including improper design, faulty construction, inspection, change in structure use, older constructions that were not designed for earthquake actions, and so on. To overcome this problem, strengthening structural members when found deficient is necessary, and it can be applied before the hazard or after the hazard. The research that has been conducted so far mostly focuses on the behavior and axial capacity of single reinforced concrete columns that have been individually jacketed with FRP, steel, and RC jacketing. However, practically, retrofitting will be conducted for all columns of a building as a frame. To widen this gap, a reinforced concrete frame was modeled and analyzed using the three jacketing methods considered in the study to compare and select the most efficient jacketing technique.*

*This research is a comparative study, considering a symmetrical G+5 office medium-rise RC building under an earth quake load that is retrofitted with steel, reinforced concrete, and carbon fiber reinforced polymer jacketing; and RC columns under axial loads. The analysis program consists of a total of 20 specimen models using finite element software ABAQUS 6.14. The comparison was in terms of two critical parameters; story displacement and story drift for a retrofitted reinforced concrete frame.*

*In conclusion, the analysis result showed that RC jacketing gives greater axial load-carrying capacity than CFRP and steel jacketing for both short and slender columns. For retrofitted frames, the maximum reduction in both story displacement and story drift is found for reinforced concrete jacketed frames as compared to the other retrofitting systems considered in the study.*

**Keywords:** *Steel jacketing, CFRP jacketing, RC jacketing, Eccentricity, Axial load, Retrofitting.*

## **ACKNOWLEDGMENT**

First and foremost, I would like to thank the Almighty God for every success in my life and the satisfactory accomplishment of this research paper.

I would like to express my deep and sincere gratitude to my research advisor, Dr. Kabtamu Getachew (Ph.D.), for the insight, support, and guidance that he has provided me throughout the research paper accomplishment. Next, my deepest gratitude goes to my co-advisor, Eng. Besukal Befekadu (Msc), for his valuable guidance and persistent help in completing this paper.

I am extremely grateful to my parents for their love, prayers, care, and sacrifices in educating and preparing me for my future. I am very much thankful to my husband, Mr. Aklilu Tezera, for his love, understanding, prayers, and continuing support to complete this research work.

Finally, my thanks go to all the people who have supported me in completing the research work, directly or indirectly.

## TABLE OF CONTENTS

DECLARATION .....	I
<i>ABSTRACT</i> .....	III
ACKNOWLEDGMENT.....	IV
LIST OF TABLE .....	IX
LIST OF FIGURE.....	XI
ACRONYMS/NOTATIONS .....	XV
CHAPTER ONE .....	1
INTRODUCTION .....	1
1.1 Background of the study .....	1
1.2 Statement of the problem .....	2
1.3 Research question .....	2
1.4 Objective of the Study .....	3
1.4.1 General Objective .....	3
1.4.2 Specific objective.....	3
1.5 Significance of the study.....	3
1.6 Scope and limitation of the Study.....	3
CHAPTER TWO .....	5
LITERATURE REVIEW .....	5
2.1 Introduction.....	5

2.2 Decision for Retrofitting .....	5
2.3 Steel Jacketing .....	6
2.4 Fiber-reinforced polymer jacketing .....	12
2.5 Concrete Jacketing .....	18
CHAPTER THREE .....	21
RESEARCH METHODOLOGY .....	21
3.1 General .....	21
3.2 Research Design.....	22
3.3 Study Variables .....	22
3.3.1 Dependent Variables .....	22
3.3.2 Independent Variables .....	22
3.4 Data Collection Process .....	23
3.5 Finite Element Modeling .....	23
3.6 Geometric Modeling .....	23
3.7 Material properties used in the finite element model.....	26
3.7.1 Concrete .....	26
3.7.1.1 Concrete damage plasticity model .....	27
3.7.1.2 Concrete Compressive Behavior.....	27
3.7.1.3 Tensile Behavior of Concrete .....	29
3.7.2 steel .....	30



3.8 Assembling parts in Abaqus .....	30
3.9 Interaction of different components.....	31
3.9.1 Concrete and Reinforcement Interaction .....	31
3.9.2 Concrete and Steel strip Interaction .....	32
3.9.3 Concrete and CFRP Interaction .....	32
3.10 Boundary and Loading Conditions .....	32
3.11. Load stepping.....	34
3.12 Meshing.....	34
3.13 Mesh sensitivity analysis .....	37
CHAPTER FOUR.....	40
ANALYSIS, RESULT, AND DISCUSSIONS .....	40
4.1 General.....	40
4.2 Validation of Finite Element Analysis by Experimental Result.....	40
4.2.1 General description of data used in the experiment.....	40
4.2.2 Comparison of the Results .....	46
4.3 Effect of length .....	47
4.4 Effect of eccentricity.....	49
4.4.1 Uni-Directional Eccentricity .....	49
4.4.2 Bi-directional eccentricity.....	54
4.5 Story Displacement.....	58

4.6 Story drift .....	62
4.7 Story drift ratio.....	67
4.8 Failure modes of columns from the FE analysis.....	70
CHAPTER 5 .....	76
CONCLUSION AND RECOMMENDATIONS .....	76
5.1 Conclusion .....	76
5.2 Recommendations.....	78
References.....	79
APPENDIX-A.....	82
APPENDIX-B.....	90
APPENDIX-C.....	92
APPENDIX-D.....	106

## LIST OF TABLE

Table 3.1: Geometric Modeling.....	24
Table 3.2: CDP parameters used in the study(Elkady, 2022).....	28
Table 3.3: Material properties(Krishna and Kumar, 2020).....	28
Table 3.4: Boundary condition .....	33
Table 3.5: Comparison of FEA and experimental results.....	39
Table 4.1: Concrete properties of validity parameters (Ezz-eldeen, 2018) .....	41
Table 4.2: Properties of CFRP sheet validity parameters (Krishna and Kumar, 2020).....	42
Table 4.3: Reinforcement steel properties of validity parameters (Krishna and Kumar, 2020)...	43
Table 4.4: Comparison of experimental (Ammar, 2015) and finite element result.....	46
Table 4.5: Axial load capacity of a retrofitted slender column.....	48
Table 4.6: Axial load capacity of retrofitted short column.....	48
Table 4.7: Results for Uni-directional eccentricity for bare and retrofitted slender RC columns.	53
Table 4.8: Results for un-directional eccentricity for bare and retrofitted short RC columns.....	54
Table 4.9: Results for Bi-directional eccentricity for bare and retrofitted slender RC columns. .	58
Table 4.10: Results for bi-directional eccentricity for bare and retrofitted short RC columns. ..	58
Table 4.11: Summary story displacement results in percent of retrofitted RC frame .....	62
Table 4.12: Percentage reductions in maximum story drift of different lateral load resisting systems compared to the bare frame.....	66
Table 4.13: Percentage reductions in maximum story drift ratio of different lateral load resisting systems compared to the bare frame.....	70
Table A.1: Summary of concrete and steel properties.....	82
Table A.2: Concrete damaged plasticity parameters used in the proposed ABAQUS model.....	82

Table A.3 Compressive behavior of concrete damage plasticity for C-25 .....	82
Table C.1: Displacement versus force for Bare, CFRP, RC and steel jacketed column. ....	92
Table C.2: Displacement versus force Uni and Bi directional eccentricity for Bare, CFRP, RC and steel jacketed column. ....	95
Table D. 1: Inter Storey displacement in the Y-direction versus Time. ....	106
Table D.2: Inter Storey Drift in the Y-direction versus Time.....	111

## LIST OF FIGURE

Figure2.1: Steel jacketing retrofit for RC column (with steel angles, Chanel, and bands jacketing) ( <i>FRP Jacketing VS Steel Jacketing - Structural Strengthening Method</i> , no date).....	11
Figure 2.2: Stress-strain relationship strengthened by steel jacketing(Belal, Mohamed and Morad, 2015).....	11
Figure 2.3: Installation of FRP wraps(AL-ALAILY, 2011).....	12
Figure 2.4: Stress-strain relationship for FRP confined concrete (Tahghighi and Gholami, 2018) .....	13
Figure 2.5: Construction techniques for column jacketing ( <i>Safeguard your structure by Column Jacketing</i> , no date) .....	19
Figure.2.6: The relationship between the moment curve in different retrofitting approaches (Nasersaeed, 2011).....	20
Figure3.1: Research design chart .....	21
Figure 3.2: Solid and line elements used in the FEM (Simulia, 2014).....	24
Figure 3.3: Plan of the building model .....	24
Figure 3.4: Sample Finite element models for (a) RC jacketed column b) steel jacketed column (c) CFRP d) steel strap.....	25
Figure 3.5: Sample finite element model for bare frames .....	25
Figure 3.6: Sample finite element model for steel jacketed frames.....	26
Figure 3.7: Concrete compression damage (Elkady, 2022).....	27
Figure 3.8: Concrete tension damage(Elkady, 2022).....	29
Figure 3.9: Elastic-plastic stress-strain response of steel.....	30
Figure 3.10: Loading condition (a) For reinforced concrete jacketing (b) For steel jacketing column (c) For CFRP jacketing .....	33
Figure 3.11: Sample Loading for CFRP jacketed frame.....	34
Figure 3.12: Sample meshing view for (a) Reinforced concrete jacketing b) CFRP jacketing c) steel jacketing of columns.....	35
Figure 3.13: Sample meshing view of Steel strap jacketed RC frame.....	36
Figure 3.14: Sample meshing view of CFRP jacketed RC frame.....	36
Figure 3.15: Sample meshing view of reinforced concrete jacketed RC frame .....	37
Figure 3.16: CFRP jacketing mesh sensitivity.....	38

Figure 3.17: Reinforced Concrete jacketing mesh sensitivity .....	38
Figure 3.18: Steel-jacketed mesh sensitivity .....	39
Figure 4.1: (a) Steel stirrup strengthened column specimens (Ezz-eldeen, 2018) (b) Finite element model of steel strap .....	41
Figure 4.2 Experimental setup for the test used for steel jacketing (Ezz-eldeen, 2018).....	42
Figure 4.3: Mold of specified dimensions and reinforcement details(Krishna and Kumar, 2020). .....	43
Figure 4.4: Loading frame with the test specimen (Krishna and Kumar, 2020) .....	44
Figure 4.5: Geometry and reinforcement details of the experiment(Tayeh et al., 2019).....	45
Figure 4.6: The A-B jacketed column specimens ready for testing(Tayeh et al., 2019). .....	45
Figure 4.7: Comparison of experimental and finite element result .....	47
Figure 4.8: Effect of length for long column .....	48
Figure 4.9: Effect of length for short column .....	49
Figure 4.10: Comparison of the efficiency of uni-directionally loaded strengthened slender column with an eccentricity of 20mm. ....	50
Figure 4.11: Comparison of the efficiency of uni-directionally loaded strengthened short column with an eccentricity of 20mm. ....	51
Figure 4.12: Comparison of the efficiency of uni-directionally loaded strengthened slender column with an eccentricity of 35mm. ....	51
Figure 4.13: Comparison of the efficiency of uni-directionally loaded strengthened short column with an eccentricity of 35mm. ....	52
Figure 4.14: Comparison of the efficiency of uni-directionally loaded strengthened short column with an eccentricity of 45mm .....	52
Figure 4.15: Comparison of the efficiency of uni-directionally loaded strengthened slender RC column with an eccentricity of 45mm. ....	53
Figure 4.16: Comparison of the efficiency of bi-directionally loaded strengthened slender RC column with an eccentricity of 20mm. ....	55
Figure 4.17: Comparison of the efficiency of bi-directionally loaded strengthened short RC column with an eccentricity of 20mm. ....	55
Figure 4.18: Comparison of the efficiency of bi-directionally loaded strengthened slender RC column with an eccentricity of 45mm. ....	56

Figure 4.19: Comparison of the efficiency of bi-directionally loaded strengthened slender RC column with an eccentricity of 35mm. ....	56
Figure 4.20: Comparison of the efficiency of bi-directionally loaded strengthened short RC column with an eccentricity of 35mm. ....	57
Figure 4.21: Comparison of the efficiency of bi-directionally loaded strengthened short RC column with an eccentricity of 35mm. ....	57
Figure 4.22: Maximum Story Displacement comparison of bare, CFRP, steel and RC jacketed frame for the top floor. ....	59
Figure 4.23: Maximum Story Displacement comparison of bare, CFRP, steel, and RC jacketed frame for ground frame. ....	60
Figure 4.24: Maximum Story Displacement comparison of bare, CFRP, steel and RC jacketed frame for the first floor. ....	60
Figure 4.25: Maximum Story Displacement comparison of bare, CFRP, steel and RC jacketed frame for the second floor. ....	60
Figure 4.26: Maximum Story Displacement comparison of bare, CFRP, steel and RC jacketed frame for the third floor. ....	61
Figure 4.27: Maximum Story Displacement comparison of bare, CFRP, steel and RC jacketed frame for the fourth floor. ....	61
Figure 4.28 Maximum Story Displacement comparison of bare, CFRP, steel and RC jacketed frame for the fifth floor. ....	62
Figure 4.29: Maximum Story drift comparison of bare, CFRP, steel, and RC jacketed frame for story one. ....	63
Figure 4.30: Maximum Story drift comparison of bare, CFRP, steel, and RC jacketed frame for story two. ....	63
Figure 4.31 Maximum Story drift comparison of bare, CFRP, steel, and RC jacketed frame for story three. ....	64
Figure 4.32 Maximum Story drift comparison of bare, CFRP, steel, and RC jacketed frame for story four. ....	64
Figure 4.33: Maximum Story drift comparison of bare, CFRP, steel, and RC jacketed frame for story five. ....	65

Figure 4.34: Maximum Story drift comparison of bare, CFRP, steel, and RC jacketed frame story for six. ....	65
Figure 4.35: Maximum Story drift ratio comparison of bare, CFRP, steel, and RC jacketed frame for story one .....	67
Figure 4.36: Maximum Story drift ratio comparison of bare, CFRP, steel, and RC jacketed frame for story two.....	68
Figure 4.37: Maximum Story drift ratio comparison of bare, CFRP, steel, and RC jacketed frame for story three.....	68
Figure 4.38: Maximum Story drift ratio comparison of bare, CFRP, steel, and RC jacketed frame story four.....	68
Figure 4.39: Maximum Story drift ratio comparison of bare, CFRP, steel, and RC jacketed frame for story five.....	69
Figure 4.40: Maximum Story drift ratio comparison of bare, CFRP, steel, and RC jacketed frame for story six. ....	69
Figure 4.41: Failure mode of short RC jacketed column.....	71
.....	71
Figure 4.42: Failure mode of steel jacketed reinforced concrete column.....	71
Figure 4.43: Failure mode of CFRP jacketed Reinforced concrete column .....	72
Figure 4.44: Failure mode of CFRP jacketed long reinforced concrete column. ....	72
Figure 4.45: Failure mode of RC jacketed long reinforced concrete column.....	73
Figure 4.46: Failure mode of steel jacketed long reinforced concrete column.....	73
Figure 4.47: Bare reinforced concrete Frame Abaqus output.....	74
Figure 4.48: Failure mode of carbon Fiber reinforced polymer jacketing Reinforced concrete FrameAbaqusoutput.....	74
Figure 4.49: Failure mode of steel jacketed Reinforced concrete Frame Abaqus output.....	75
Figure 4.50: Failure mode of RC jacketed Reinforced concrete Frame Abaqus output.....	75



## ACRONYMS/NOTATIONS

CAE	Computer-aided engineering
CFRP	Carbon fiber reinforced polymer
CDP	Concrete damage-plasticity model
$d_c$	Damage variable
$d_t$	Damage variable in tension
E	Elastic modulus
$E_{co}$	Initial undamaged modulus of elasticity
$E_{co}$	Initial undamaged modulus of elasticity
FEA	Finite element analysis (FEA)
FE	Finite element
FEM	Finite Element Method
Fsu	Ultimate tensile strength
RC	Reinforced concrete
Mpa	Mega Pascal
$u$	Ultimate stress,
$\varepsilon_t$	Total tensile strain
$\varepsilon_{ot}^{el}$	Elastic tensile strain corresponding to the undamaged material
$\varepsilon_{su}$	ultimate strain
$\varepsilon_c$	Total compressive strain
$\varepsilon_c^{in}$	In-elastic strain
$\varepsilon_c$	Compressive strain

## **CHAPTER ONE**

### **INTRODUCTION**

#### **1.1 Background of the study**

Concrete structures consist of several elements, the most important of which is the column. Columns are critical elements in many structures as local member failure may lead to a partial or complete collapse of the structure. If a column is structurally deficient due to damage, which may be caused by an earthquake, design or construction error, or from reinforcement corrosion, a retrofit can be a suitable option to bring it back into service.

When the column cannot sustain the applied loads because of an increase in load, a change in the use of the structure, or an initial poor design of the structure, the column must be strengthened. Jacketing is one of the preeminent and most commonly utilized strategies to retrofit R.C. columns. On the other hand, the structural usage of buildings sometimes changes, causing higher loads beyond the designed capacity of structures, which in turn results in structurally deficient members. Under such conditions, the strengthening of civil engineering structures becomes very important to enhance the ultimate capacity. In addition to this, after a hazard occurs on structures, the affected member needs to be repaired so that it can sustain loads.

There are different types of strengthening and retrofitting methods used, which affect the global or local member performance of a structural member under the given loading condition. Column jacketing enhances the axial capacity of the column. We can have different types of column jacketing. For reinforced concrete columns, there are mainly three methods of retrofitting. Reinforced concrete, steel, and fiber-reinforced polymer jacketing are commonly used before hazard and after the hazard occurred.

The retrofit strategy may involve targeted repair of deficient regions, providing systems to increase stiffness and strength, or providing redundant load-bearing systems. In general, a combination of different strategies may be used in the retrofitting of the structure. The selection of a specific rehabilitation technique should be based on the retrofit objectives as well as economic considerations.

## **1.2 Statement of the problem**

The research that has been conducted so far mostly focuses on the behavior and axial capacity of reinforced concrete columns that have been individually jacketed with FRP, steel, and RC jacketing, both experimentally and analytically. However, practically, retrofitting will be conducted for all columns of a building as a frame. To widen this gap, a reinforced concrete frame was modeled and analyzed using the three jacketing methods to compare and select the most efficient jacketing technique.

## **1.3 Research question**

- How does the axial eccentric load affect the capacity of RC columns jacketed with steel, fiber-reinforced polymer, and reinforced concrete?
- What is the significant effect of column length variation on the axial capacity of the retrofitted column considered in the study?
- Which of the three strategies used in the study for retrofitting is the most effective?

## **1.4 Objective of the Study**

### **1.4.1 General Objective**

The objective of this paper is to perform a comparative study on the efficiency of concrete jacketing, steel jacketing, and CFRP jacketing on retrofitting RC columns using the finite element package ABAQUS.

### **1.4.2 Specific objective**

To investigate and compare:

- The axial capacity of a retrofitted RC column based on axially eccentric load and column length.
- The effect of eccentric loading on steel, CFRP, and RC-jacketed reinforced concrete columns.
- The efficiency of steel, CFRP, and RC jacketing on reinforced concrete frames is based on story displacement and story drift.

## **1.5 Significance of the study**

This research is a finite element study on retrofitting columns using the three different methods of jacketing technique, which gives some information for the readers about the performance of each retrofit technique based on the comparative analysis result found from the FEM analysis.

This model can also be used as a starting point for further research.

## **1.6 Scope and limitation of the Study**

This research is limited to a five-bay by three-bay G+ 5 stories RC building, which is regular in plan and elevation. as well as a single column of 150x150x3650mm for the slender column and a

square column of dimension 150x150x1200mm for the short column. Any other cross-sections, different depth-to-height ratios, and reinforcement variations are not considered. The frames are assumed to be firmly fixed at the bottom, and the soil–structure interaction is neglected. Four strengthened RC frames for lateral load and sixteen single columns for axial load capacity are analyzed. The analysis is completed using the finite element package ABAQUS 6.14-1.

## **CHAPTER TWO**

### **LITERATURE REVIEW**

#### **2.1 Introduction**

Retrofitting is a technical intervention in the structural system of a building that improves the resistance to the earthquake by optimizing the strength, ductility, and earthquake loads. The strength of the building is generated from the structural dimensions, materials, shape, number of structural elements, etc. The ductility of the building is generated from good detailing, materials used, degree of seismic resistance, etc. Earthquake load is generated from the site seismicity, the mass of the structures, the importance of buildings, the degree of seismic resistance, etc. Due to the variety of structural conditions of the building, it is hard to develop typical rules for retrofitting. Each building has different approaches depending on the structural deficiencies. Hence, engineers are needed to prepare and design the retrofitting approaches. In the design of retrofitting approach, the engineer must comply with the building codes. The results generated by the adopted retrofitting techniques must fulfill the minimum requirements of the building codes, such as deformation, detailing, strength, etc. (*Structural Retrofitting - AMERICAN GEOSERVICES*, no date).

#### **2.2 Decision for Retrofitting**

Retrofitting is needed when the assessment of structural capacity results in the insufficient capacity to resist the forces of expected intensity and acceptable limit of damages. It is not merely the poor quality of materials and damage to structural elements that serve as the reasons to retrofit a building. Changes in the building's function, changes in environmental conditions, and changes in valid building codes could also be the reasons for retrofitting. Retrofitting must be conducted by experts from each field. In the most retrofitting process, an engineer plays the

main role. An engineer must assess and analyze the structural capacity. An engineer must also design the best retrofitting techniques to strengthen the structural deficiencies.

Some factors that should be considered to decide whether to retrofit or not are:

- a) The technical aspects include the testing of materials and structural analysis. These measures are important to understand the condition of the structures related to the recent building codes.
- b) Cost intervention Cost and benefit analysis must be conducted before the decision is made.
- c) Importance of building each building is built for its purpose. Some old buildings have extra values, such as historical values, that will strongly affect the final decision.
- d) Availability of adequate technology some retrofitting techniques need “modern “technology to implement it. A decision of retrofitting must consider whether the region provides such technology.
- e) Skilled workmanship to implement the proposed measures some retrofitting techniques need unusual construction methods to implement it. Skilled workmanship must be provided to implement the proposed measures.
- f) Duration of works. Some retrofitting works will consume less time to finish, but others take more time to complete. Hence, it is important to take into consideration the duration of work (Shrestha *et al.*, 2009).

### **2.3 Steel Jacketing**

(Issa *et al.*, 2010) conducted an experimental, theoretical and numerical investigation to evaluate the behavior of reinforced concrete columns strengthened externally with steel jacket or fiber composite under axial loads. The experimental program presented six rectangular reinforced concrete columns with the same dimension of  $150 \times 200 \times 1200$  mm. The steel jacket consisted of four vertical angles at column corners and horizontal steel plates welded to the corner angles

and distributed along column height. The main parameter was the type of external strengthening method. For the steel jacket, the variables were the size of corner angles and the spacing between the steel plates. From the experimental study, it was concluded that increasing the area of corner steel angles and decreasing the spacing between the steel pattern plates of steel jackets increase the ultimate carrying capacity and ductility of strengthened columns.

(Adam *et al.*, 2009) performed experiments on axially loaded RC columns strengthened by steel cages as well as numerical models using the finite element method to verify the obtained experimental results. Also, a parametric study was carried out to analyze the influence of each of the parameters on the behavior of RC columns strengthened by steel cages. The study considered these parameters: the size of the angles; the yield stress of the steel of the cage; the compressive strength of the concrete in the column; the size of the strips; the addition of an extra strip at the ends of the cage; and the friction coefficient between the layer of mortar and the steel of the cage. The obtained results of this parametric study were that the slippage between the steel cage and the column can be reduced by increasing the size of the strips due to the greater stiffness of the steel cage in the transverse direction. This improvement in confinement would also result in a better transmission of loads between the cage and the column by the shear stress mechanism.

(Tarabia and Albakry, 2014) studied the behavior and efficiency of reinforced concrete square columns strengthened by steel angles and strips (steel cage). The main studied parameters were: the size of the steel angles, strip spacing, grout material between column sides and angles, and the connection between the steel cage to the specimen head. Two different concrete strengths 57.8 MPa and 47.5 MPa were also considered in this study. All the specimens were tested under concentric axial loads till failure. This study concluded that jacketing by steel angles and strips proved to be a very efficient strengthening method. The gain in the axial load capacity of the



strengthened columns was obtained from 1.35 to 2.10 for the un-strengthened column. This gain was due to the confinement effect of the external steel cage, and the ability of the steel angle to resist an extensive part of the applied axial load. The failure in most of the strengthened specimens was due to the buckling of the steel angle followed by the crushing of the original columns. The axial ductility of the strengthened column was also obtained to be increased by 50%.

(Belal *et al.*, 2019) performed both experimental and numerical investigations on seven specimens under compressive axial loading. The specimens were strengthened with different steel jacketing configurations. Three different vertical steel elements (angles, channels, and plates) were chosen with the same total horizontal cross-sectional area. Three studied variables were: the shape of the main strengthening system (using angles, C-sections, and plates), size, and the number of batten plates. This study concluded that angles and channels proved to be performed similarly, but steel plates resulted in less capacity for the column, due to the thinness of the plate. Batten plates had variable results based on which cross-section was used. The jacketing system with channels resulted in higher strength than angles. But the angles were found to be benefited more from improved confinement stress due to the discrete thicker plates. Additionally, the columns with angles experienced less deformation than the other steel jacket/cage cross-sections. Additional consideration was recommended when using C-sections with batten plates or plates only, since their thinner thicknesses may present buckling problems.

(Ezz-eldeen, 2018) conducted both experimental and numerical investigations on fifteen-column specimens to evaluate the efficiency of steel angles and the strip jacketing method under eccentric loads. Four different eccentricities were used in the study. Then the twelve columns were divided into three groups and strengthened with three different angle sets (two same angles

in each set) on the compression side and two same angles on the tension side separately. It was concluded that increasing the covered area of the steel jacket increased the load-carrying capacity of the strengthened columns. Finally, a parametric analysis was conducted using ANSYS finite element model for proposing practically used dimensions in strengthening columns subjected to different eccentricities. Columns with cross-sectional areas ranging from  $25 \times 35$  cm to  $25 \times 120$  cm were analyzed for this purpose and presented in a tabular form for practical application.

(Pasala N., Dipti R.& Durgesh C., 2018) uses steel caging techniques for the seismic strengthening of reinforced concrete (RC) columns of rectangular cross-sections. The steel cage consists of angle sections placed at corners and held together by battens at intervals along the height. In the study, a rational design method was developed to proportion the steel cage considering its confinement. An experimental study was also carried out to verify the effectiveness of the proposed design method and detailing of steel cage battens within potential plastic hinge regions. One ordinary RC column and two strengthened columns were investigated experimentally under constant axial compressive load and gradually increasing reversed cyclic lateral displacements. Both strengthened columns showed excellent behavior in terms of flexural strength, lateral stiffness, energy dissipation, and ductility due to the external confinement of the column concrete. The proposed model for confinement effect due to the steel cage reasonably predicted moment capacities of the strengthened sections, which matched with the observed experimental values.

(Khalifa and Al-Tersawy, 2014) developed a practical-based analytical model and designed an experimental program on seven low-strength reinforced concrete columns. Two series of strengthening procedures were considered in this study. The first series contained four steel

angles and uniform intervals of strips. Steel casing by four plates connected with or without dowels was included in the second series. This study concluded that the load-carrying capacity could be enhanced up to 66% using steel angle and strip strengthening series. This capacity proved to be doubled with steel casing by four plate series. This study also concluded that the increase in strip thickness and reduction in strip spacing resulted in more effective strength and ductility than the increase in the steel angle dimensions. The presence of dowels exhibits the comparatively slower failure of the column in steel casing techniques. Finally, the experimental and analytical results were compared and showed to be obtained a good agreement in them. The proposed analytical model accounted for the composite action for concrete confinement and enhancement of the local buckling of the steel elements.

(Uy, 2002) investigated the behavior of steel plate jacketed reinforced concrete columns. Both short columns and slender columns were incorporated. The dimension of the columns was 150 mm x 150mm x450mm for the short column and 150 mm x 150mm x815mm for the slender column. All specimens were tested under concentric loading until failure. The failure mode for both short columns and slender columns was local buckling of the steel plates and local crushing of the concrete. The result showed that the ultimate strength of the bonded column was increased by around 90% to 110%.

(Li *et al.*, 2005) proposed a constitutive model based on experimental results to evaluate the behavior of concrete strengthened by externally bonded steel plates. To obtain sufficient data, an experimental program was first conducted. 60 concrete cylinders with a 300 mm diameter and 600mm length jacketed with different types and thicknesses of steel jackets were tested. The model is based on the stress and strain values of the intersection points and regression analysis

was used to determine the parameters. The result showed that the steel plate jacketing is efficient for the uni-axially loaded column to increase strength and ductility.



Figure 2.1: Steel jacketing retrofit for RC column (with steel angles, Chanel, and bands jacketing)  
(FRP Jacketing VS Steel Jacketing - Structural Strengthening Method, no date)

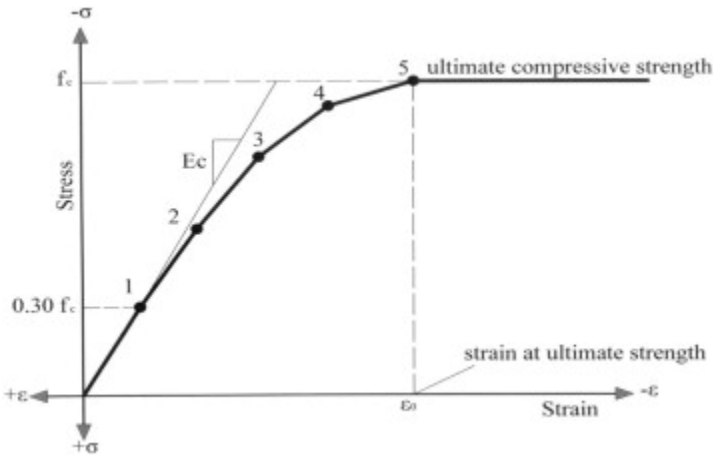

Figure 2.2: Stress-strain relationship strengthened by steel jacketing(Belal, Mohamed and Morad, 2015)

## 2.4 Fiber-reinforced polymer jacketing

Research on strengthening concrete columns with FRP had been developed dramatically in recent years.

(Bagus, Widiarsa and Hadi, 2013) presented the results of an experimental study on the performance of carbon fiber reinforced-polymer wrapped square reinforced concrete columns under eccentric loading. The influence of the number of CFRP layers, the magnitude of eccentricity, and the presence of vertical CFRP straps were investigated. The results of this study showed that CFRP wrapping enhanced the load-carrying capacity and ductility of the columns under eccentric loading. Furthermore, the application of the vertical CFRP straps significantly improved the performance of the columns with large eccentricity.

(Campione and Miraglia, 2003) FRP-reinforced concrete members with different shapes of the cross-section were analyzed and a model to evaluate the confining pressure and the ultimate strain was developed. The model was then examined with experimental data and showed good agreement.



Figure 2.3: Installation of FRP wraps(AL-ALAILY, 2011)

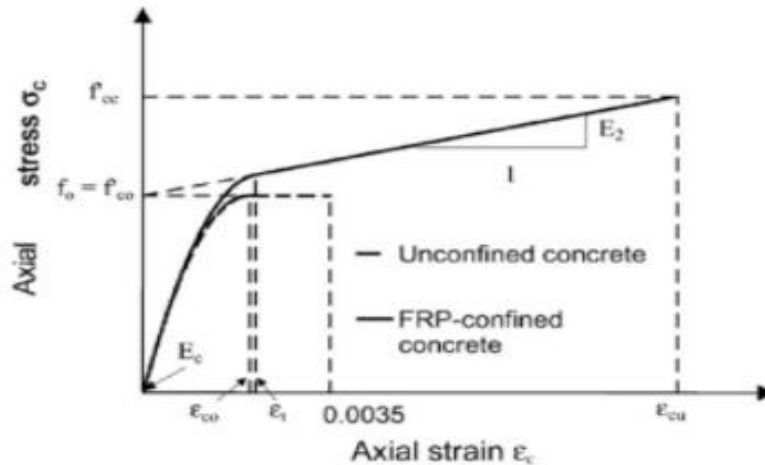

Figure 2.4: Stress-strain relationship for FRP confined concrete (Tahghighi and Gholami, 2018)

Muhammad N. S. Hadi et al. (2012) have conducted an experimental study on the performance of carbon-fiber-reinforced polymer (CFRP) wrapped square reinforced concrete (RC) columns under eccentric loading. The experimental program consisted in testing a total of 12 RC specimens under compression loading. The specimens had four 12 mm diameter deformed bars as longitudinal steel reinforcement and 8 mm diameter plain bars spaced at 100 mm as transverse steel reinforcement (ties). The tie rebar spaced at 50 mm was applied at both ends of the specimens to prevent premature failure at the locations. The specimens were divided into three groups: unwrapped, wrapped with one layer of CFRP, and wrapped with three layers of CFRP. Each group consisted of four specimens; one specimen was tested concentrically, one was tested under a 25 mm eccentric load, and one was tested under a 50mm eccentric load. Two different monitoring systems were used to measure the displacement of the columns. For concentric loading, one LVDT was connected directly to the testing machine to measure the axial displacement of the column during the test. Data read from this LVDT were recorded at the same time as load data were recorded by the testing machine. A second LVDT, a laser LVDT, was also used in addition to the first one for an eccentric load to measure the lateral deflection ( $\delta$ ) of

the column. The second LVDT was placed horizontally near the mid-height of the column. When the specimen and the instrumentation were placed in position and initial calibration was done, the compression testing then started. The column was tested under displacement control with a loading rate of 0.5 mm/min, and the endpoint position was set at 50 mm. Based on the experimental work carried out in this study, the following conclusions were drawn:

- CFRP wrapping had a more significant effect on the maximum load of eccentrically loaded columns compared to concentrically loaded columns.
- The CFRP wrapping enhanced the performance of the columns by postponing the rupture of the concrete and reinforcement, which means it increased the column ductility.
- In columns with a large eccentricity, which means with a large bending moment, the presence of CFRP straps produced higher ductility than in columns wrapped horizontally with a similar number of CFRP layers.

(Abdel-Hay, 2014) conducted an experimental study on the behavior of R.C. square columns with poor concrete at the upper part, strengthened with CFRP. Ten square columns of height 2000 mm and a cross-section of 200 x 200 mm are tested. One of them is a controlled specimen and the other nine specimens are divided into three groups. All specimens had the same longitudinal reinforcement and stirrups. A high-strength carbon fiber fabric, SIKA WRAP 300 C, was used for jacketing the tested columns. The CFRP materials had a nominal thickness of 0.167 mm. surface of the concrete column is Prepared by using a hammer and blower to remove the weak element on the concrete cover. The column was chamfered by a radius of 20 mm. Then the epoxy paste is applied on the column surface to fill the uneven surface of the concrete. SIKA DUR 41 CF was used to bond the CFRP with a column, then rolling the CFRP was laminated by a special laminating- roller to ensure that the CFRP is saturated with epoxy resin and there are no

air voids between the fibers and concrete surface. All columns were loaded with a 500-ton hydraulic machine in the material laboratory. The applied load was read out on the load cell scale. LVDTs were placed at the upper and lower part of the column to measure the longitudinal strains, and electrical strain gages of 20 mm gage length were used to measure the fiber strain.

Conclusions: The following conclusions are drawn from this work. 1) Partial strengthening of square columns with poor concrete at the upper part can be used. It is significant to wrap the poor part only using one layer of CFRP. 2) Increasing the jacket height will provide a higher ductility for wrapped columns without a significant increase in the ultimate load of columns. 3) Confined part must be provided with a corner radius to increase concrete strength as the upper part is quite weak. 4) The ultimate load of the wrapped column increases as the concrete strength of the upper part increases, while the ductility decreases. 5) Increasing the top concrete height causes an increase in ductility, but the failure load decreases. 6) Ductile failure mode was achieved in specimens of the top concrete height of 500 mm, while in the case of 350 mm top concrete height, the failure mode was brittle.

(Jameel, Sheikh and Hadi, 2017) have carried out experimental work on the Behavior of circularized and FRP-wrapped hollow concrete specimens under axial compressive load. This paper investigates the suitability of the circularization technique for strengthening square hollow concrete specimens. A total of eight specimens were made from normal-strength concrete. The specimens were divided into two groups: solid and hollow specimens. All the specimens were 300 mm in height and 106 mm in cross-section. The hollow specimens had a central square hole of 35 mm sides. Each group consisted of four specimens. The first specimen in each group was the reference specimen. The second specimen was constructed with 20 mm round corners and was wrapped with two layers of CFRP, which simulates the conventional strengthening method.



The third specimen was circularized with full-length plain concrete segments and wrapped with two layers of CFRP. The fourth specimen was circularized with concrete segments which were 20 mm shorter than the length of the specimen and wrapped with two layers of CFRP. All specimens were tested under axial compression loading. For testing the universal Denison compressive testing machine with a maximum load capacity of 5000 kN is used. A transducer (LVDT) was used. For the circularized specimens, the LVDT was mounted onto a frame of two circular rings. For square specimens, a square test setup was designed. The travel linear variable differential transformer (LVDT) was mounted onto two box frames that were fixed at the top and bottom of the specimen by steel bolts. All specimens were tested under a displacement-controlled axial load at the rate of 0.5 mm/min. The data were recorded every two seconds.

Conclusion: 1. Circularization proved to be an effective method in strengthening CFRP confined square hollow concrete specimens similar to CFRP confined solid concrete specimens. 2. The experimental investigations carried out in this paper demonstrated that the specimens circularized with full-length concrete segments confined with CFRP achieved higher ultimate axial load than the specimens circularized with short concrete segments confined with CFRP. 3. When the effect of circularization is compared with rounding the corners of the CFRP confined specimens, after excluding the contribution from section enlargement, the circularization technique contributed less to the yield stress of the hollow specimens than to the yield stress of the solid specimens.

(Sadeghian, Rahai and Ehsani, 2010) have conducted experimental work on the Study of Rectangular RC Columns Strengthened with CFRP Composites under Eccentric Loading. This paper presents the results of experimental studies on reinforced concrete columns strengthened with carbon fiber reinforced polymer (CFRP) composites under the combination of axial load

and bending moment. A total of seven RC specimens were designed with a rectangular section (200 mm x300 mm). The test portion of each specimen had a height of 1,500 mm and each haunched head had a height of 600 mm. The specimens were tested under compression eccentric loading up to failure. Three different FRP thicknesses of 1.8, 2.7, and 4.5 mm (two, three, and five layers); four fiber orientations of 0°, 90°, +45°, and 45° concerning an axis perpendicular to the column axis; and two eccentricities of 200 and 300 mm were investigated. Two columns were un strengthened; two were strengthened with two longitudinal layers and one transverse layer of CFRP; two others were strengthened with four longitudinal layers and one transverse layer of CFRP, and the last column was strengthened with two diagonal layers of CFRP. One specimen of each group was tested under an eccentricity of 200 mm, and another was tested under an eccentricity of 300 mm. The specimen DD` was tested under an eccentricity of 300 mm only. All specimens were reinforced with 4 $\phi$  12 mm longitudinal ribbed bars ( $f_y=465$  Mpa) symmetrically placed. Transverse reinforcement was provided with rectangular ties  $\phi$  6.5@200 mm made of smooth bars ( $f_y=325$  Mpa). A hydraulic actuator was used to apply the axial load to the columns. A total of six linear variable displacement transducers (LVDTs) and 26 strain gauges were used for every specimen. The specimens were tested using a 600 kN capacity compression actuator under displacement control and the data were monitored using an automatic data collecting system. Displacements and strains were monitored by a digital data logger system. The tests were performed up to the failure of the specimens. Force, displacements, and strains were obtained during the test and were filed by computer software. The following conclusions are drawn: 1. The strengthened specimens had similar bilinear load-displacement curves as the un-strengthened specimens. The first part of all curves was approximately linear up to the yield point when the tension steel bars yielded. The axial secant stiffness and yield strength were

improved with increasing axial stiffness of the FRP. After the yielding point, the FRPs were effectively activated, so the plastic region of all curves had limited stiffness degradation. The axial tangent stiffness was improved with increasing longitudinal stiffness of the FRP. The maximum load-carrying capacity of each specimen was reached at the FRP failure point when the longitudinal fibers of the FRP failed in tension. 2. The moment-curvature behavior showed that longitudinal layers improved the bending stiffness and moment capacity of the specimens, but curvature capacities were not generally improved. The behavior of the specimen with angle orientation was a little different. In this case, not only the bending stiffness and moment capacity were enhanced, but also the curvature capacity was improved. 3. When the strengthened columns fail in tension-controlled failure, the transverse layers could not make any improvement on the confinement of the compression side of the section. In this region, the concrete behavior is similar to the unconfined concrete. 4. The sine-shaped model for second-order deformation is in good agreement with experimental data for different levels of deformation from the linear region up to the failure point on the prismatic part of the specimens. The model can be used for the design calculation of RC columns strengthened with CFRP composites.

## **2.5 Concrete Jacketing**

Concrete jacketing involves the encasement of the existing column with an additional layer of concrete plus additional longitudinal and transversal reinforcement. Concrete jacketing was widely used in Mexico City after the 1985 earthquake and was the most popular retrofitting method at the time. The technique was found experimentally to be effective. The stiffness of the retrofitted structural system was also significantly increased which could cause the structure to attract more seismic load (Wu, Liu, and Oehlers, 2016).

(Vandoros and Dritsos, 2008) evaluated the strengthening effect of concrete jackets in terms of different reinforcement welding techniques in the concrete jacket. The original reinforced columns were 250 mm x 250 mm in cross-section and 1800 mm in height with a foundation of 1400 mm by 780 mm by 650 mm to simulate full-scale ground floor columns. The thickness of the concrete covers was 75 mm and no special treatment was incorporated at the interface between the original column and the cover. The columns were concentrically loaded until failure. The result showed that the behavior of reinforced concrete columns can be significantly improved by concrete jacketing. They found that the load-carrying capacity can be increased by 3.44 times, and the stiffness by 2 times.

In conclusion, the result in this area showed that concrete cover jacketing can improve the load-carrying capacity of the concrete column by a significant amount.

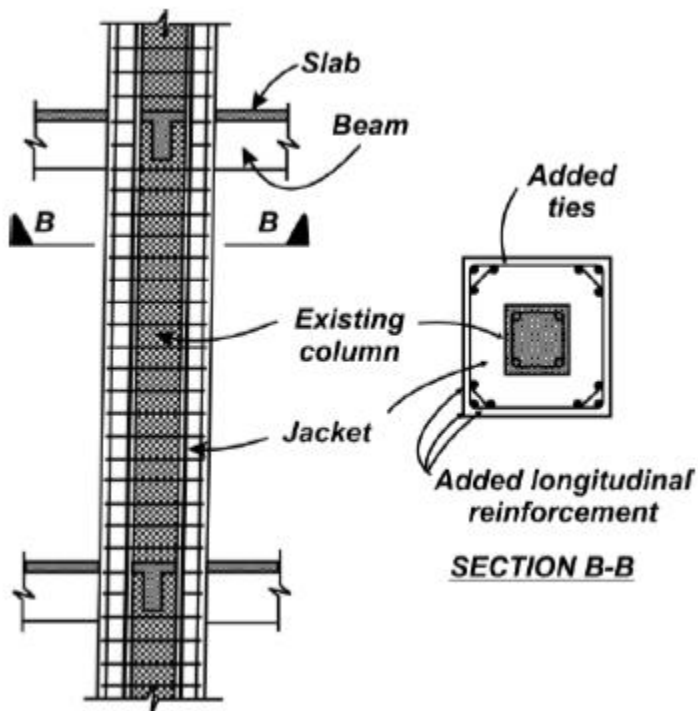

Figure 2.5: Construction techniques for column jacketing (*Safeguard your structure by Column Jacketing*, no date)

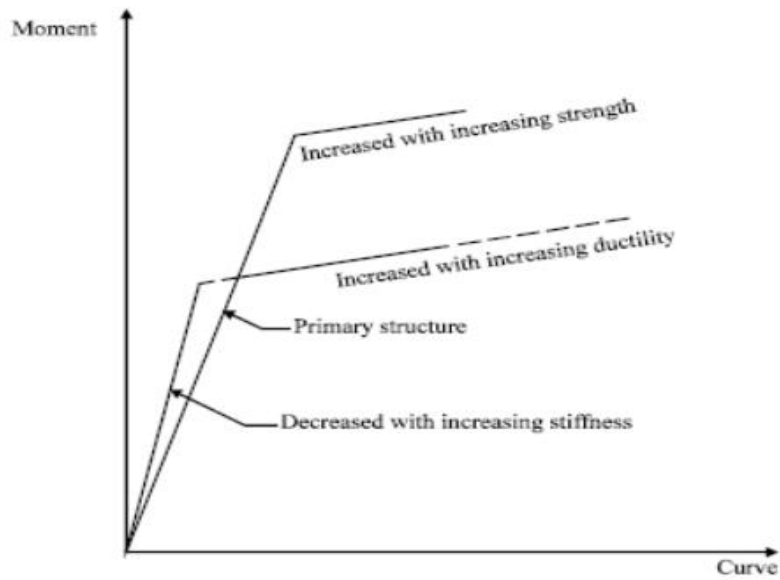

Figure.2.6: The relationship between the moment curve in different retrofitting approaches (Nasersaeed, 2011)

CHAPTER THREE

RESEARCH METHODOLOGY

3.1 General

This chapter presents and describes the approaches and techniques the researcher used to collect data and investigate the research problem.

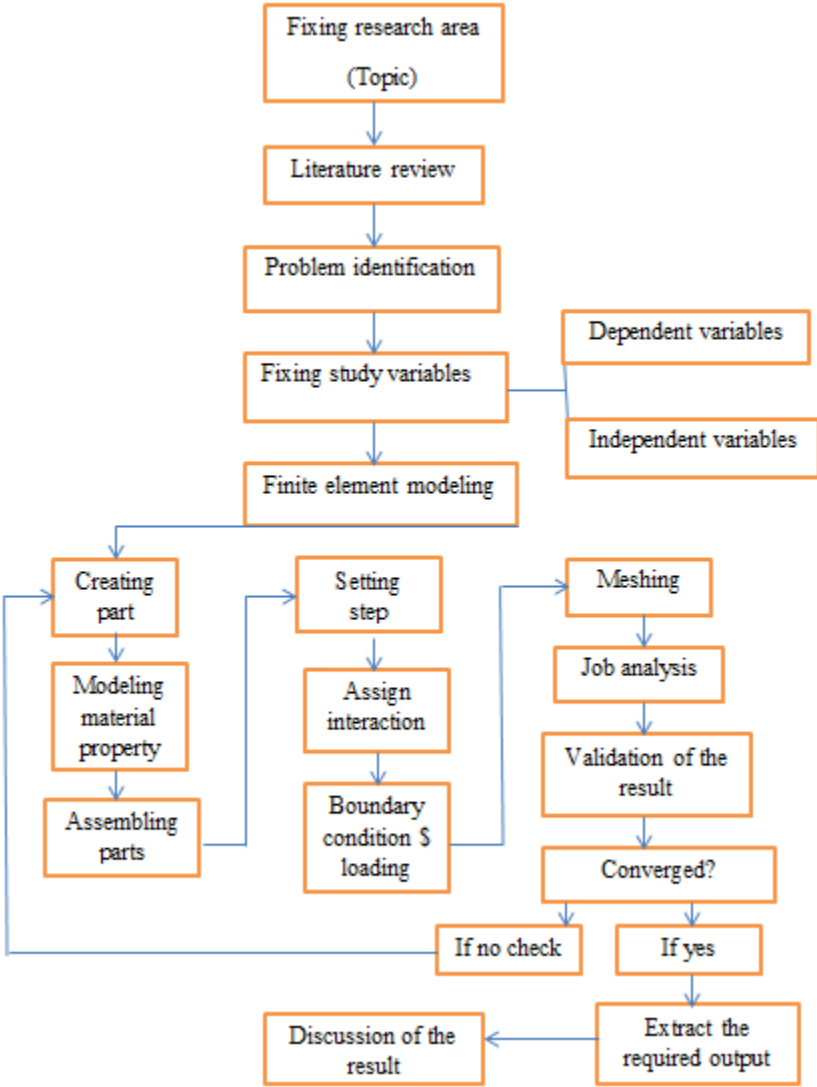

Figure3.1: Research design chart

## **3.2 Research Design**

Various methods can be used to conduct research, and these can be either quantitative, qualitative, or a combination of both. Based on this, the paper has a quantitative nature (comparative), aiming to gather data from twenty modelings and analysis using ABAQUS software. The lateral load analysis of the study is based on the new code EBCS EN 1998-1:2015. The model for the lateral load analysis is a G+5 building with a plan dimension of 30m x 17.6m and a story height of 3.3m. To create 3D models, the finite element software Abaqus6.14 is used.

## **3.3 Study Variables**

### **3.3.1 Dependent Variables**

The dependent variables of this study are:

- Axial load resistance
- Story displacement
- Story drift

### **3.3.2 Independent Variables**

The independent variables are,

- Eccentricity
- Column length
- Types of jacketing

### **3.4 Data Collection Process**

The data used for this research is collected from existing literature related to retrofitting reinforced concrete columns with concrete, steel, and carbon fiber reinforced polymer jacketing. A finite element analysis (ABAQUS) software was used to perform several finite element Analyses to observe the behavior of columns with concrete, steel, and carbon fiber reinforced polymer jacketing. The observations from the finite element analysis were compared with the previous experimental results for validation purposes and the validated model for the parametric study of the research paper.

### **3.5 Finite Element Modeling**

The Finite Element Method (FEM) is a procedure for the numerical solution of the equations that govern the problems found in nature. Usually, the behavior of nature can be described by equations expressed in differential or integral form. For this reason, the FEM is understood in mathematical circles as a numerical technique for solving partial differential or integral equations. When referred to the analysis of structures, the FEM is a powerful method for computing the displacements, stresses, and strains in a structure under a set of loads. Finite element analysis (FEA) is an extremely useful tool in the field of civil engineering for numerically approximating physical structures that are too complex for regular analytical solutions (*Introduction to the Finite Element Method for Structural Analysis*, 2009).

### **3.6 Geometric Modeling**

For concrete, CFRP, steel angles, and strips the C3D8R elements are used in the model. The C3D8R element is an eight-node reduced integration brick element with three translational degrees of freedom at each node. Two-nodded truss elements designated as T3D2 have been used to model the longitudinal and tie reinforcements.



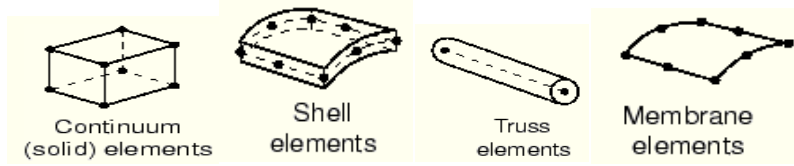

Figure 3.2: Solid and line elements used in the FEM (Simulia, 2014).

Table 3.1: Geometric Modeling

Type	Dimension(mm)
Short column	150*150*1200
Long column	150*150*3650
Frame ground floor	500*500*3650
Frame column 1nd-5th floor	500*500*3300
Frame beam	300*400
Steel jacket	40*40*2

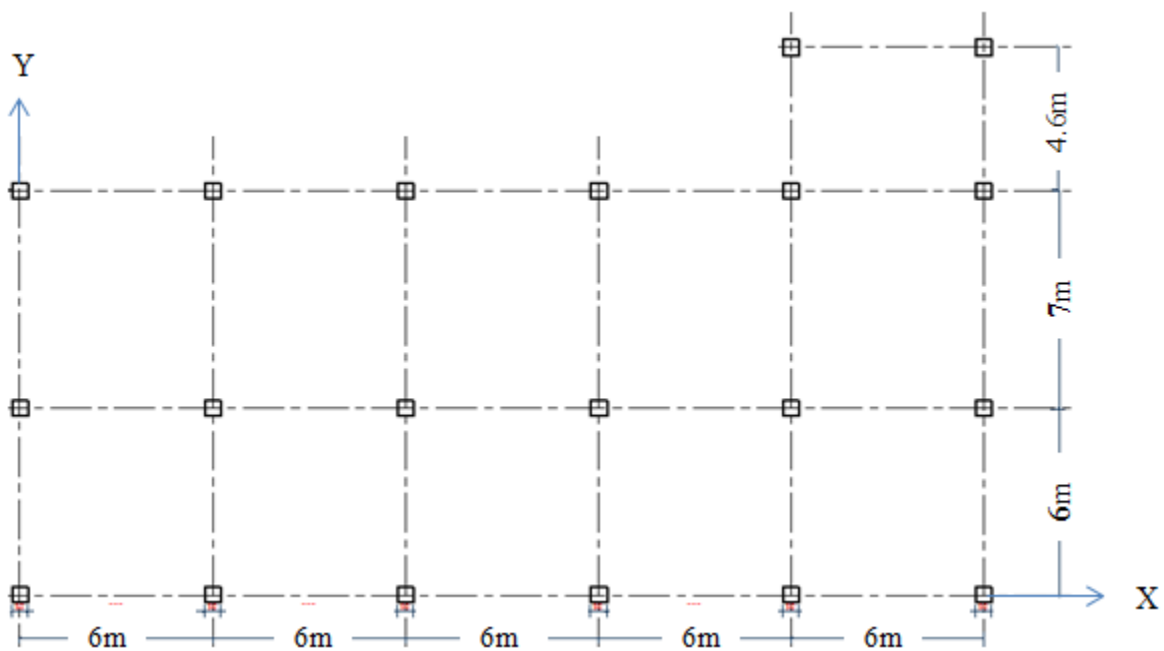

Figure 3.3: Plan of the building model

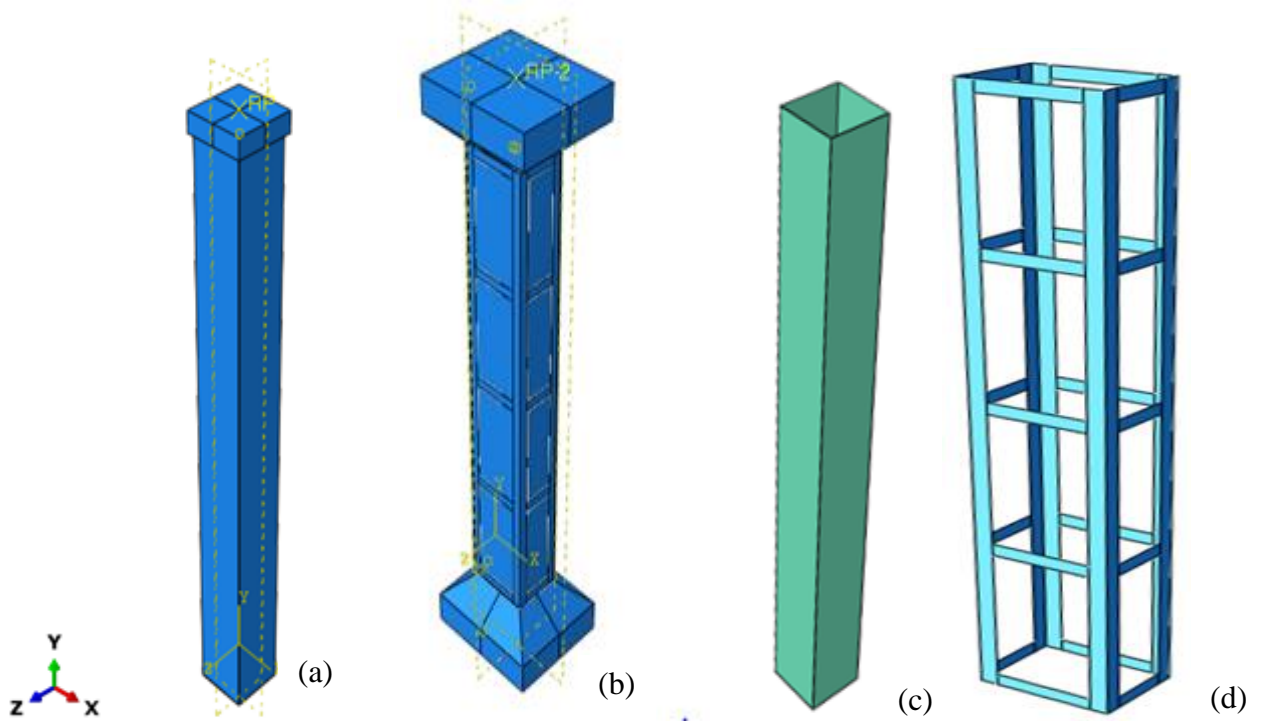

Figure 3.4: Sample Finite element models for (a) RC jacketed column b) steel jacketed column (c) CFRP d) steel strap

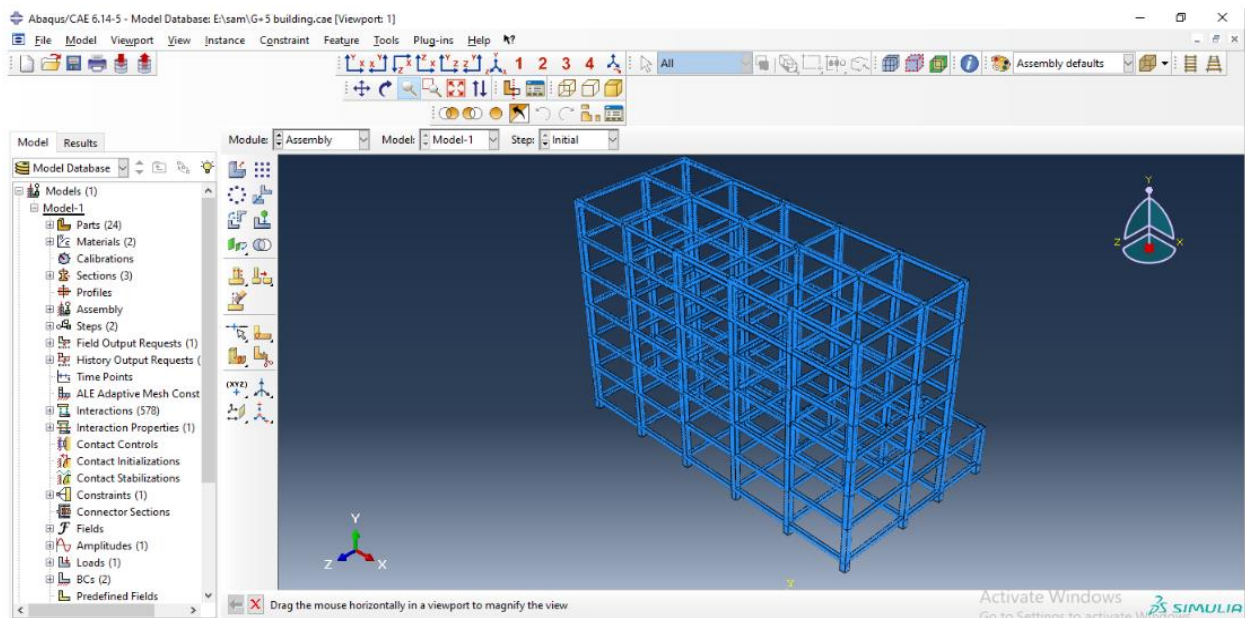

Figure 3.5: Sample finite element model for bare frames

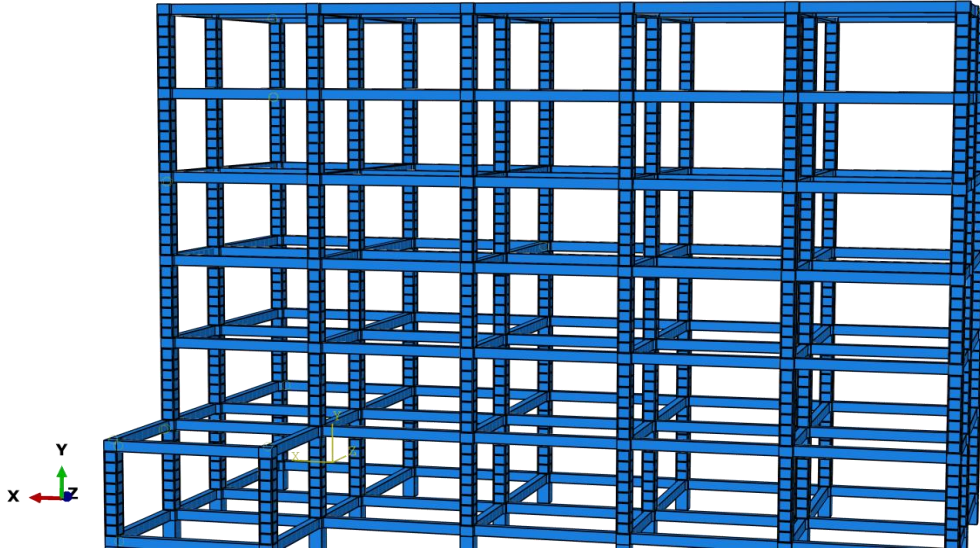

Figure 3.6: Sample finite element model for steel jacketed frames

### 3.7 Material properties used in the finite element model

#### 3.7.1 Concrete

The material properties in the finite element method for concrete are compressive behavior and tensile behavior. The compressive stress-strain relationship for concrete is based on numerical expressions proposed by (Desayi and Krishnan, 1964)

$$f = \frac{E_c * \varepsilon}{\left[1 + \left(\frac{\varepsilon c}{\varepsilon_o}\right)^2\right]} \quad (3.1)$$

$$\varepsilon_o = \frac{2 * f_c}{E_c} \quad (3.2)$$

The modulus of elasticity of concrete for compression is calculated based on the ACI 318-14 equation.

$$E_c = 4730 \sqrt{f'_c} \quad \text{where } f'_c \text{ in Mpa} \quad (3.3)$$

ABAQUS provides the concrete damage plasticity model which describes the compressive and tensile behavior of concrete and it is capable of representing the linear, plastic, and damage portion of the stress-strain curve for concrete.

### 3.7.1.1 Concrete damage plasticity model

The concrete damage plasticity (CDP) model uses a stress-strain relationship to define relative concrete damage. The model is a continuum, plasticity-based damage model for concrete that is capable of predicting both the compressive and tensile behavior of the concrete material. Compression hardening and tension stiffening models are used to define the complete behavior of concrete under loads. Therefore, the CDP model has been used to simulate the concrete material behavior in the FEM investigation of RC column jacketing using concrete jacketing, steel jacketing, and FRP Jacketing. In ABAQUS, the input for this model is stress-inelastic curves and converted to stress-plastic strain curves automatically using the damage variable (Le Minh *et al.*, 2021).

### 3.7.1.2 Concrete Compressive Behavior

The uniaxial compression stress-strain curve is defined in terms of the inelastic strain and the damage portion that is given by the parameter,  $d_c$  (damage parameter).  $d_c$  represents the degradation of the elastic stiffness of the material in compression.

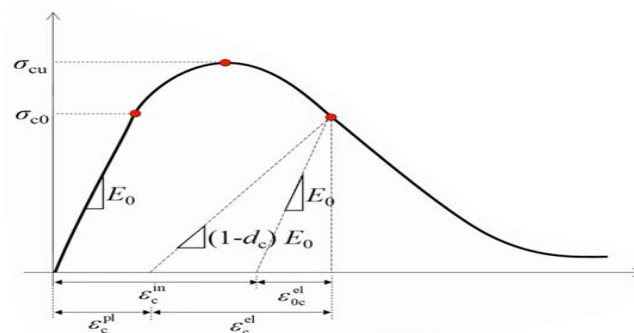

Figure 3.7: Concrete compression damage (Elkady, 2022)

The following equation calculates the inelastic strain and damage parameters.

$$\varepsilon_c^{in} = \varepsilon_c - \frac{f_c}{\varepsilon_c} \quad (3.4)$$

The compression damage parameter is calculated using the following formula

$$d_c = 1 - \frac{\sigma_c}{E_o (\varepsilon_c - \varepsilon_c^{pl})} \quad (3.5)$$

The important parameters necessary for the concrete damage plasticity model are given below.

Table 3.2: CDP parameters used in the study(Elkady, 2022)

CDP Parameters	Values used in FEM
Dilation angle	40
Flow potential eccentricity	1.12
Stress ratio	1
Shape factor	0.6667
Viscosity Parameter	0.01

Table 3.3: Material properties(Krishna and Kumar, 2020)

Concrete grade	C-25
poison ratio of concrete	0.2
Density of concrete	24KN/m3
Grade of steel rebar	S-460
Grade of steel jacket	S-500
Density of steel	78KN/m3
Modulus of elasticity of steel	200GPa
Poison ratio of steel	0.3
density of CFRP	1.8g/cm3

### 3.7.1.3 Tensile Behavior of Concrete

The tensile behavior of concrete is characterized by a linear elastic stress-strain relationship before the concrete reaches its tensile strength,  $f_{ct}$ , and a bilinear stress  $\sigma_t$ -crack width relationship for the post-peak softening behavior.

The uniaxial tensile strength of concrete,  $f_t$  is calculated based on the ACI 318-14 equation for normal-weight concrete.

$$f_t = 0.56\sqrt{f'_c} \quad (\text{Where } f'_c \text{ in Mpa}) \quad (3.6)$$

Concrete tension properties for the damage model are defined in two stages: the linear elastic portion up to the tensile strength and the nonlinear post-peak portion, which is called tension stiffening. The first part is defined using the modulus of elasticity of concrete ( $E_c$ ) and the yield stress of concrete in tension. After peak point, strain softening.

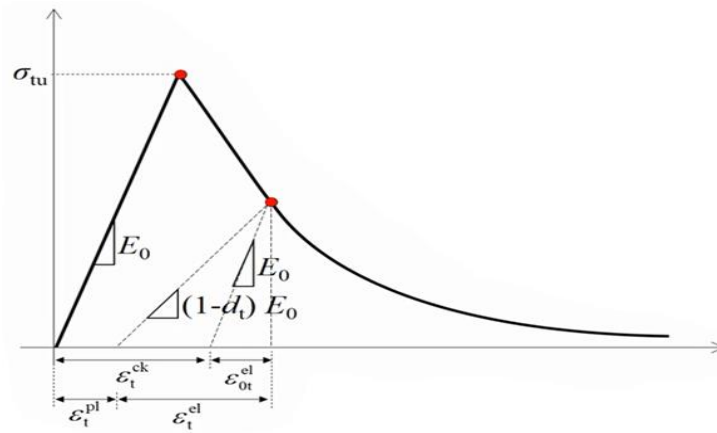

Figure 3.8: Concrete tension damage(Elkady, 2022)

The tensile damage parameter is calculated using the following equation

$$d_t = 1 - \frac{\sigma_t}{\sigma_{t0}} \quad (3.7)$$

Once the damage parameter is calculated the cracking and yield strain is automatically calculated using the following equation

$$\varepsilon_t^{ck,h} = \varepsilon_t - \frac{\sigma_t}{\varepsilon_c} \quad (3.8)$$

$$\varepsilon_t^{pl} = \varepsilon_t - \frac{\sigma_t}{\varepsilon_o} \left( \frac{1}{1-d_t} \right) \quad (3.9)$$

### 3.7.2 steel

The steel for the finite element models has been assumed to be an elastic-plastic material and identical in tension and compression. It is based on a linear elastic response up to yielding and constant stress from the point of yielding to the ultimate strain. The steel property is approximated by the elastic region and plastic region. The elastic region is presented by young's modules and the plastic region by yield stress, ultimate stress, and plastic strain.

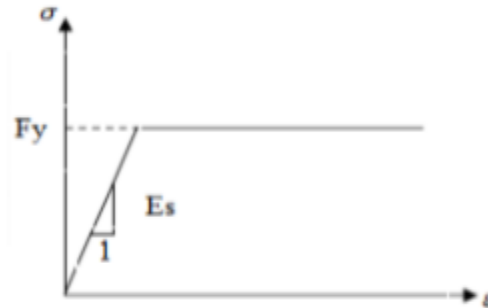

Figure 3.9: Elastic-plastic stress-strain response of steel

### 3.8 Assembling parts in Abaqus

A physical model is typically created by assembling various components. The assembly interface in Abaqus allows analysts to create a finite element mesh using an organizational scheme that parallels the physical assembly. In Abaqus, the components that are assembled are called part instances.

The mesh is created by defining parts and then assembling instances of each part. Each part can be used (instanced) one or more times, and each part instance has its position within the

assembly. This organization of the model definition matches the way models are created in Abaqus/CAE, where the assembly can be created interactively.

### **3.9 Interaction of different components**

Many engineering problems involve contact between two or more components. One of the most important factors that affect the accuracy of the results of simulation is modeling the interaction between assembled parts correctly. In the simulation analysis, choosing suitable contact conditions between different parts of the model must be carefully considered to allow the transfer of the forces between these parts. The ABAQUS library provides a wide range of contact models required to define the interaction between different parts of any model.

#### **3.9.1 Concrete and Reinforcement Interaction**

When modeling rebar as a wire, the rebar has to interact with the concrete beam. This can be modeled in multiple ways in Abaqus using constraints. Constraints in Abaqus allow the modeling of kinematic relationships between points and surfaces. One way to do it is to make a constraint so that the rebar becomes embedded in the concrete region. The embedded element technique is used to specify that an element or groups of elements are embedded in "host" elements. The embedded element technique can be used to model the interaction between the reinforcement and the concrete. Abaqus searches for the geometric relationships between the nodes of the embedded elements and the host elements. If a node of an embedded element lies within a host element, the translational degree of freedom at the node is eliminated, and the node becomes an "embedded node." The translational degree of freedom of the embedded node is constrained to the interpolated values of the corresponding degree of freedom of the host element. Embedded elements are allowed to have a rotational degree of freedom, but these rotations are not constrained by the embedding. To ensure bonding between the concrete and the



reinforcing bars, the longitudinal bar and stirrup reinforcements were defined as “embedded” in the concrete, which effectively couple the behavior of the rebar with the adjacent concrete medium (Cheng, 1995).

To get the actual behavior of the steel-jacketed RC column in the FEM model, it is necessary to define proper interaction among these contact surfaces. In finite element study, “tie” and “embedded” constraints are used for combining different parts. In the “tie” constraint there is no relative movement between two surfaces and hence each node of the two surfaces moves together showing a perfect bond between them. It is necessary to define the master and slave surface for the „tie” constraint. The embedded constrained have been used in this research. The embedded constraint used for concrete reinforcement interaction allows bonding the nodes of reinforcing bars to the compatible degrees of freedom of the host region elements (concrete).

### **3.9.2 Concrete and Steel strip Interaction**

In this research, a tie constraint is used. In each steel-strip interaction, the steel angle is defined as the master, and the concrete is defined as the slave. In the tie constraint, a perfect bond between the master and slave surfaces is assumed, and hence each node of the bodies in this constraint moves together and no slip occurs between the nodes of the master and slave.

### **3.9.3 Concrete and CFRP Interaction**

The tie constraint is used. CFRP is defined as master and concrete is defined as a slave in the interaction.

### **3.10 Boundary and Loading Conditions**

After modeling and assembling the section, the appropriate boundary conditions were created using the boundary condition option. For the axially loaded column, pin support was applied at the bottom, and at the top, a vertical compressive load was applied on the top vertically

downward by fixing the translation in X and Y directions, the loading was expressed in the form of displacement. The displacement was applied in small increments to overcome numerical instability difficulties that could be occurred when a large load had been applied suddenly.

Table 3.4: Boundary condition

Support type	$U_1$	$U_2$	$U_3$
Bottom	0	0	0
Top	0	-5	0

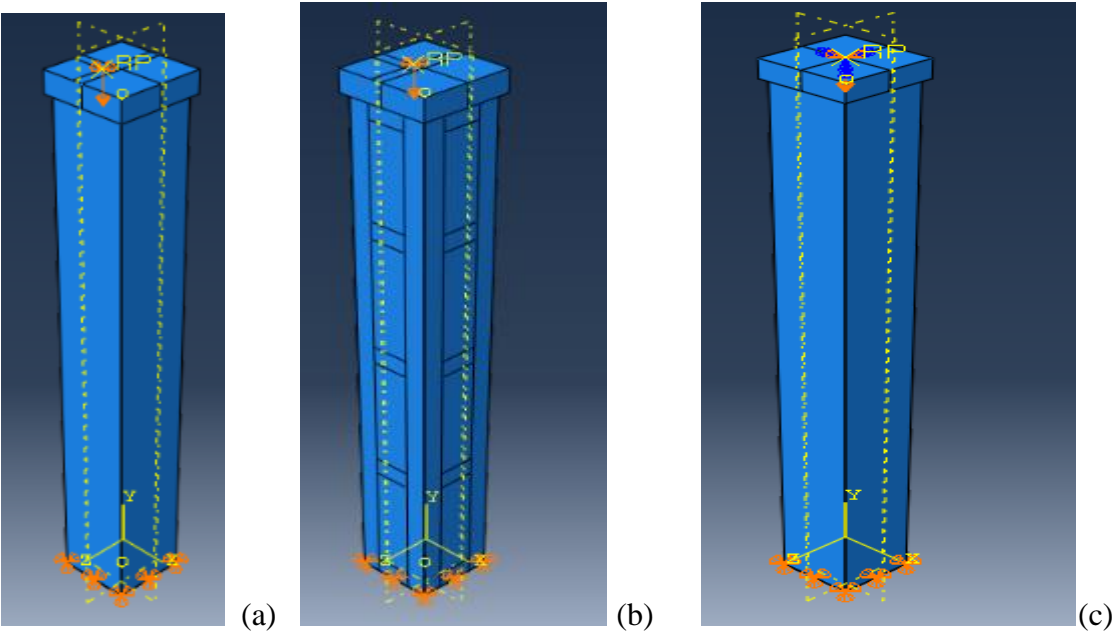

Figur 3.10: Loading condition (a) For reinforced concrete jacketing (b) For steel jacketing column (c) For CFRP jacketing

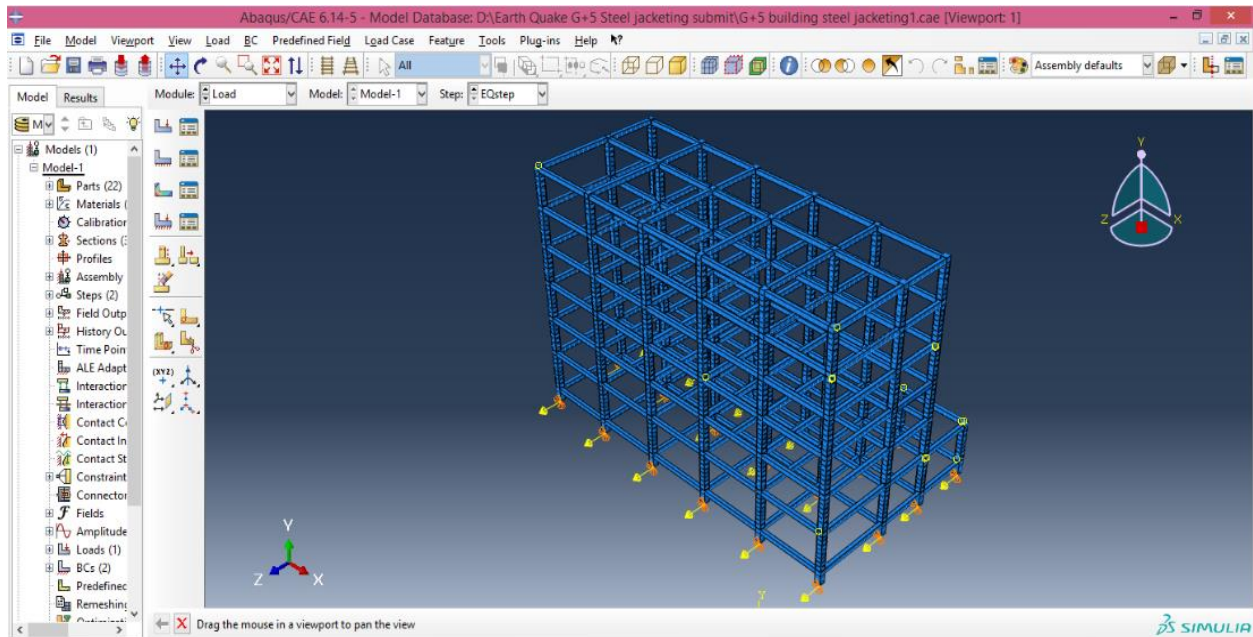

Figure 3.11: Sample Loading for CFRP jacketed frame

### 3.11. Load stepping

For the nonlinear analysis, automatic time stepping in the Abaqus program predicts and controls load step size. Displacement-controlled finite-element analyses were used in this research. the maximum and the minimum load step sizes are required for the automatic time stepping. In this particular study period, the maximum number of increments, the initial increment, minimum increment size, and maximum increment size were set to  $3.5,1*10^5$ , 0.005,  $1E^{-05}$ , and 1 respectively.

### 3.12 Meshing

Meshing is the process in which the continuous geometric space of an object is broken down into thousands or more shapes to properly define the physical shape of the object. Meshing, also known as mesh generation, is the process of generating a two-dimensional or three-dimensional grid; it involves dividing complex geometries into elements that can be used to discretize a domain.

Creating the most appropriate mesh is the foundation of engineering simulations. The mesh influences the accuracy, convergence, and speed of the simulation. Predictably shaped and mathematically defined volumes allow governing equations to be solved. Typically, the equations solved on these meshes are partial differential equations.

The Mesh module allows a generation of meshes for parts and assemblies created within Abaqus/CAE. Various levels of automation and control are available so that you can create a mesh that meets the needs of your analysis. As with creating parts and assemblies, the process of assigning mesh attributes to the model, such as seed mesh techniques and element types, is feature-based. As a result, you can modify the parameters that define a part or an assembly, and the mesh attributes that you specified within the Mesh module are regenerated automatically. In this research, hex meshing was used for all samples in this research paper.

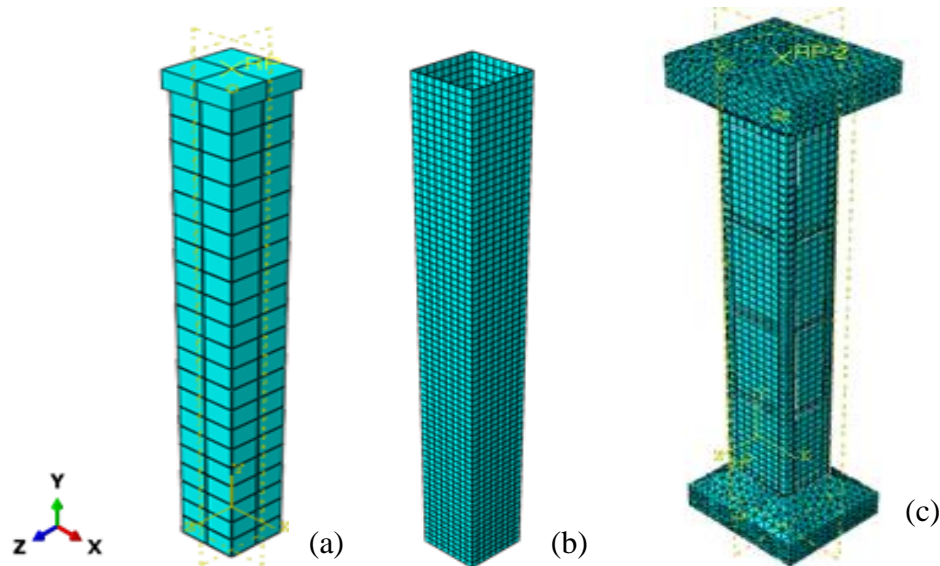

Figure 3.12: Sample meshing view for (a) Reinforced concrete jacketing (b) CFRP jacketing (c) steel jacketing of columns

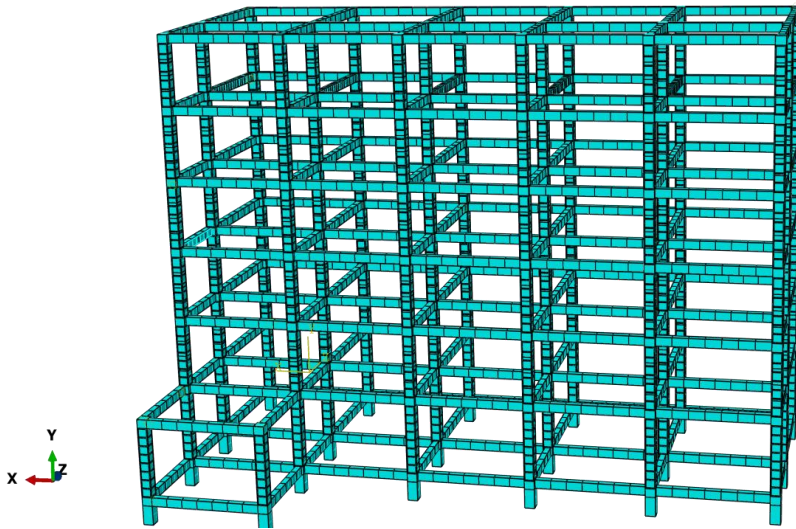

Figure 3.13: Sample meshing view of Steel strap jacketed RC frame

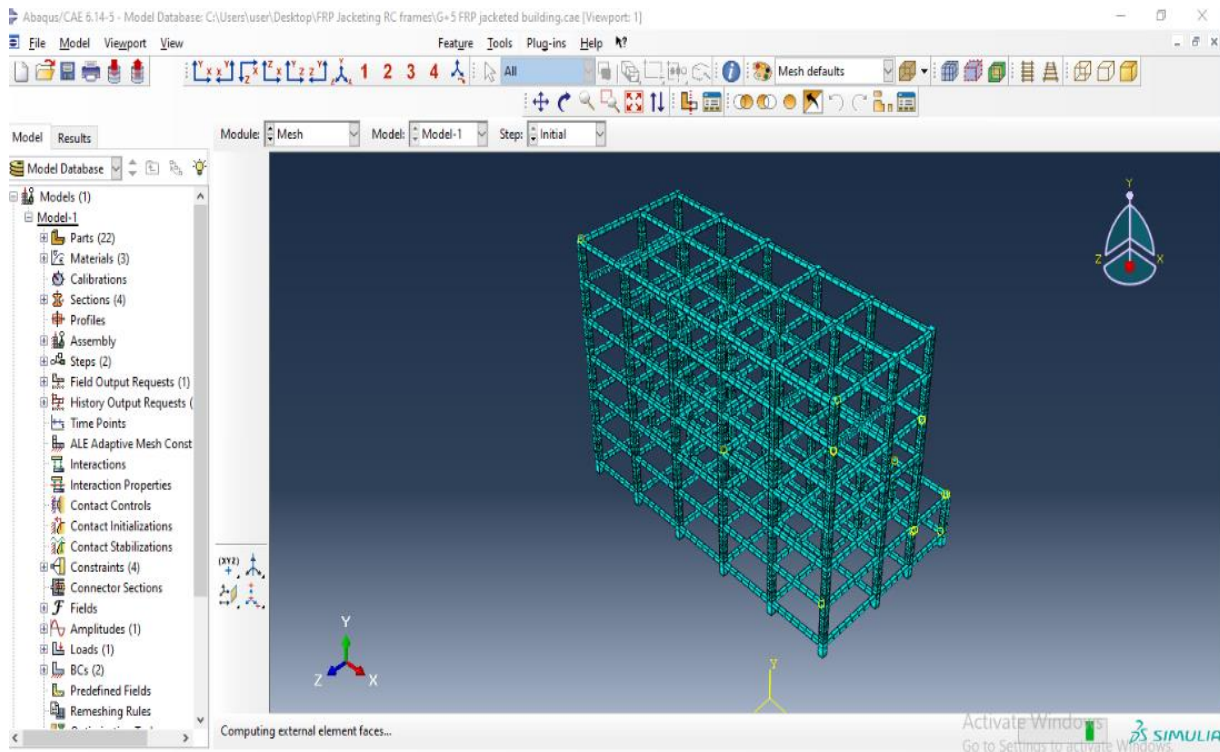

Figure 3.14: Sample meshing view of CFRP jacketed RC frame

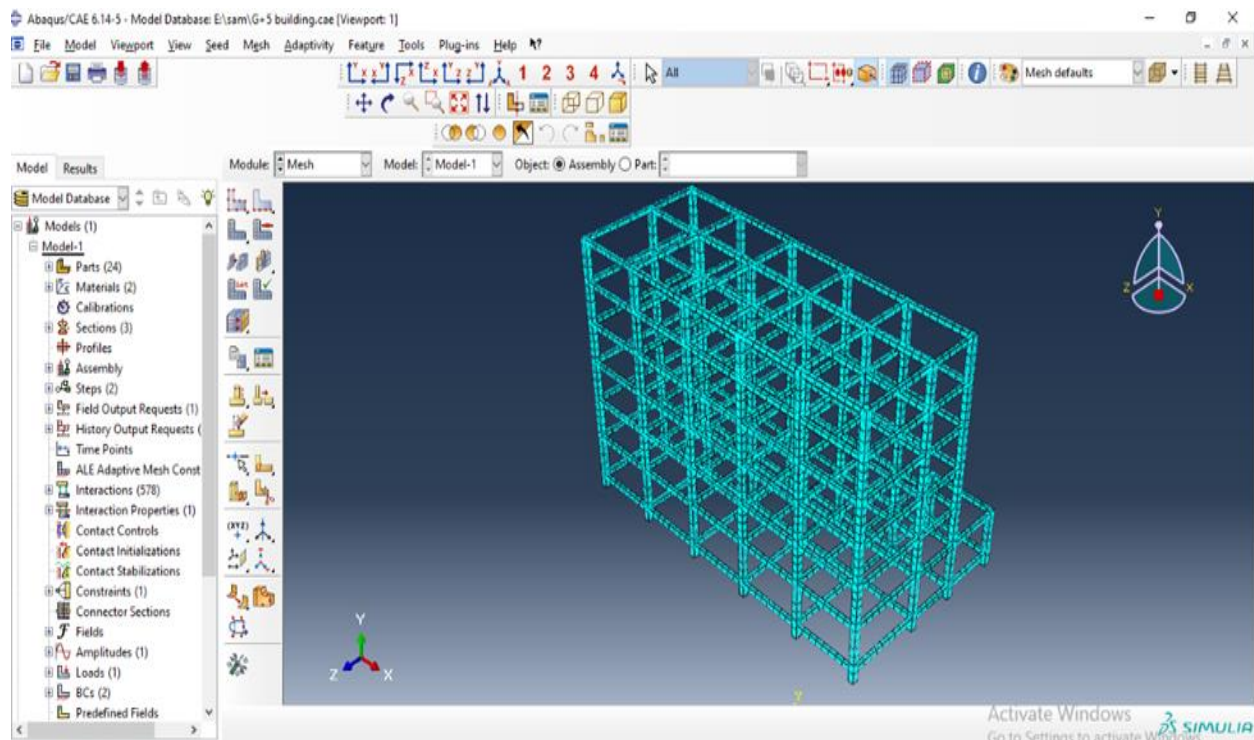

Figure 3.15: Sample meshing view of reinforced concrete jacketed RC frame

### 3.13 Mesh sensitivity analysis

The solutions obtained by solving a finite element model depend on the size of the elements used. By increasing the mesh density (reducing the size of elements and thus reducing the volume of elements), the numerical solution of the problem converges into a single solution. Of course, the smaller the mesh, the more physical memory is used to solve the finite element model, and the simulation duration increases. To investigate the influence of mesh sizes on the performance of a column, three models were used for each of four samples of bare RC column, steel jacketed RC column, reinforced concrete jacketed RC column and CFRP jacketed RC column with the same geometry and loading condition but different element sizes for sensitivity checks. The mesh size used for the single axial loaded column is 15 mm for all models for comparison purposes, and it is in good agreement with the results obtained in the experiment.

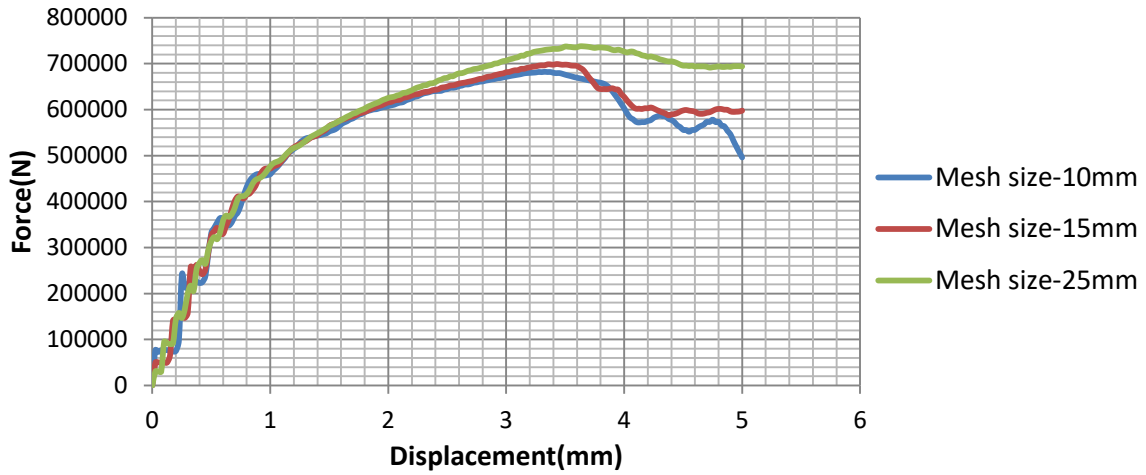

Figure 3.16: CFRP jacketing mesh sensitivity

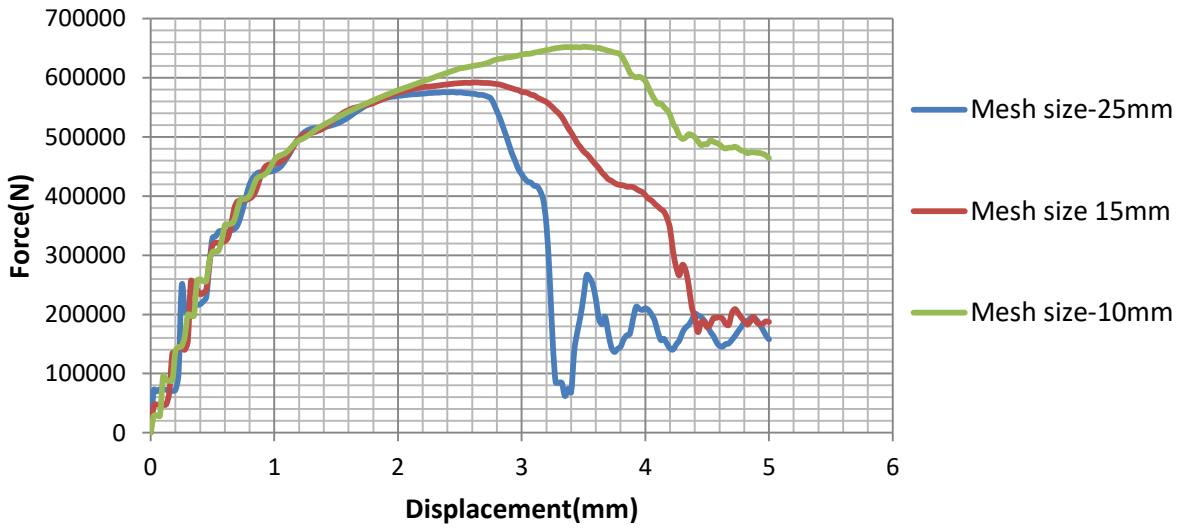

Figure 3.17: Reinforced Concrete jacketing mesh sensitivity

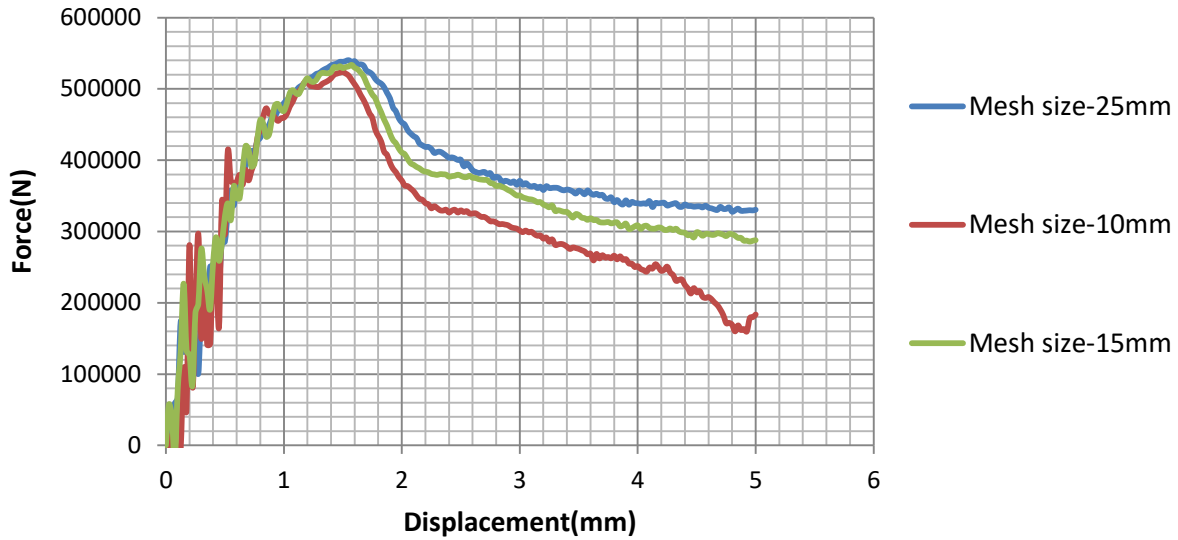

Figure 3.18: Steel-jacketed mesh sensitivity

Table 3.5: Mesh sensitivity analysis comparison with experimental results

		ultimate load(KN)			Difference from Experimental result (%)
		Mesh size	Finite Element result	Experimental result	
(Krishna and Kumar, 2020)	CFRP Jacketing	10	682	743	8.2
		15	699		5.92
		25	738		0.67
(Tayeh <i>et al.</i> , 2019)	Concrete Jacketing	10	576	604	4.64
		15	592		1.99
		25	652		7.36
(Ezz-eldeen, 2018)	Steel Jacketing	10	524	554	5.4
		15	534		3.61
		25	540		2.53

Therefore, from the mesh sensitivity analysis 25mm mesh size was used for CFRP jacketing, and steel jacketed reinforced column, 15mm was used for concrete jacketing.



## **CHAPTER FOUR**

### **ANALYSIS, RESULT, AND DISCUSSIONS**

#### **4.1 General**

Finite element analyses were conducted using the software ABAQUS 6.14-1 to compare the performance of a single concrete column under axial load and reinforced concrete frame structure under earthquake loading with different retrofitting systems such as steel, CFRP, and RC jacketing. Results of Response Spectrum Analysis have been used to observe and compare the floor response of all the models in terms of the following parameters.

- 1) Story displacement
- 2) Story drift
- 3) Axial load

#### **4.2 Validation of Finite Element Analysis by Experimental Result**

Existing experimental data is used to validate the finite element models developed for columns under axial load. To investigate the performance of different jacketing systems for reinforced concrete, a lot of parameters have been considered in this study. Some of these are material models for steel, CFRP, and concrete, different loading rates, boundary conditions, mesh size, and element type for validation purposes. Validation is important to establish the reliability of the model's performance and, ultimately, the results of the research itself.

##### **4.2.1 General description of data used in the experiment**

###### **a) Steel jacketing**

The concrete is defined as an isotropic material in the modeling and should be deliberately expressed in verification.

Table 4.1: Concrete properties of validity parameters (Ezz-eldeen, 2018)

Concrete properties	Magnitude
Elastic Modulus	37300
Poisson's Ratio	0.19
Compressive strength	25mpa

An experiment carried out by (Ezz-eldeen, 2018) was used to compare the FEM of the RC column. The dimension of the column was 120X160X1000 mm with a column head of 260X300 mm at the top and bottom. In the experiment, both the pure axial load and the eccentric load were considered with main reinforcement and stirrup at 120 mm. The yield strength of all reinforcements was 240 MPa and the steel jacket was  $3.8 \times 10^5$  (kN/m<sup>2</sup>).

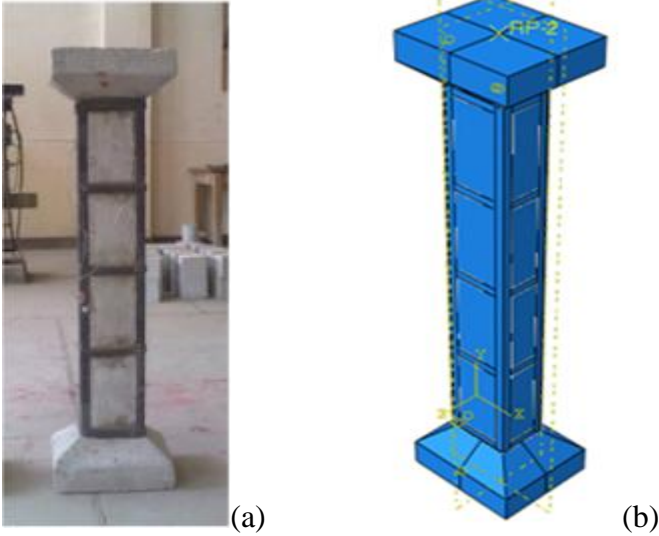

Figure 4.1: (a) Steel stirrup strengthened column specimens (Ezz-eldeen, 2018) (b) Finite element model of steel strap



Figure 4.2 Experimental setup for the test used for steel jacketing (Ezz-eldeen, 2018)

The columns were tested under static load using a 1000 KN capacity hydraulic jack mounted on a steel frame. The result found was a failure load of 554KN for the control column and 643KN for the 10mm eccentrically loaded column.

b) CFRP jacketing

Table 4.2: Properties of CFRP sheet validity parameters (Krishna and Kumar, 2020)

Property	Details
Tensile strength	4900MPa
Elastic modulus	235000MPa
Nominal fiber Thickness	0.128mm
Grade of concrete for CFRP jacketing	M-20

Table 4.3: Reinforcement steel properties of validity parameters (Krishna and Kumar, 2020)

Steel properties	Magnitude
Diameter of the longitudinal bar	12mm
Diameter of tie bar	8m
Elastic Modulus	200000 Mpa
Poisson's Ratio	0.3
Yield Strength	500

Test specimens having a length of ( $L= 1500\text{mm}$ ), depth ( $d=150\text{mm}$ ), and width ( $b=150\text{mm}$ ) were used. The columns are reinforced with 4 bars of 12 mm diameter as main reinforcement and 8 mm diameter ties are provided as shear reinforcement spaced at 150 mm c/c as medium scale RC column. Additionally, horizontal and vertical reinforcement was provided as shown in figure 4.3 (Krishna and Kumar, 2020).



Figure 4.3: Mold of specified dimensions and reinforcement details(Krishna and Kumar, 2020).

The column specimens are tested on a 2000kN capacity loading frame under uni-axial compressive load. Steel plates were used as column caps to ensure parallel surface to columns which distribute the load uniformly with minimum eccentricity. The loading rate of the loading

frame is maintained at 10kN and this rate is maintained constant up to cracks appearing on the surface of the column specimen(Krishna and Kumar, 2020).

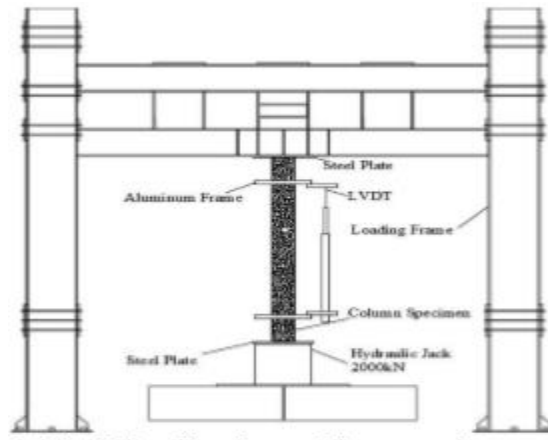

Figure 4.4: Loading frame with the test specimen (Krishna and Kumar, 2020)

The result obtained from this experiment was an ultimate load of 743kN for a retrofitted column wrapped with a single layer of CFRP.

#### c) RC jacketing

(Tayeh *et al.*, 2019) conducted an experimental study on Repairing and Strengthening Damaged RC Columns Using Thin Concrete Jacketing. The experimental programs included reinforced concrete column specimens with cross sections of 100 mm × 100 mm and a height of 300 mm. The thickness of jacketing applied was 25 mm with 4Ø8 mm main steel-reinforcing bars with a length of 280 mm and a diameter of 8 mm used at the four corners of the column cores. 3Ø2.5 mm transverse steel reinforcement ties are used and fixed to the longitudinal steel bars with a vertical spacing of 90mm. All the column specimens that are jacketed are loaded with approximately 90% of their actual axial capacity.

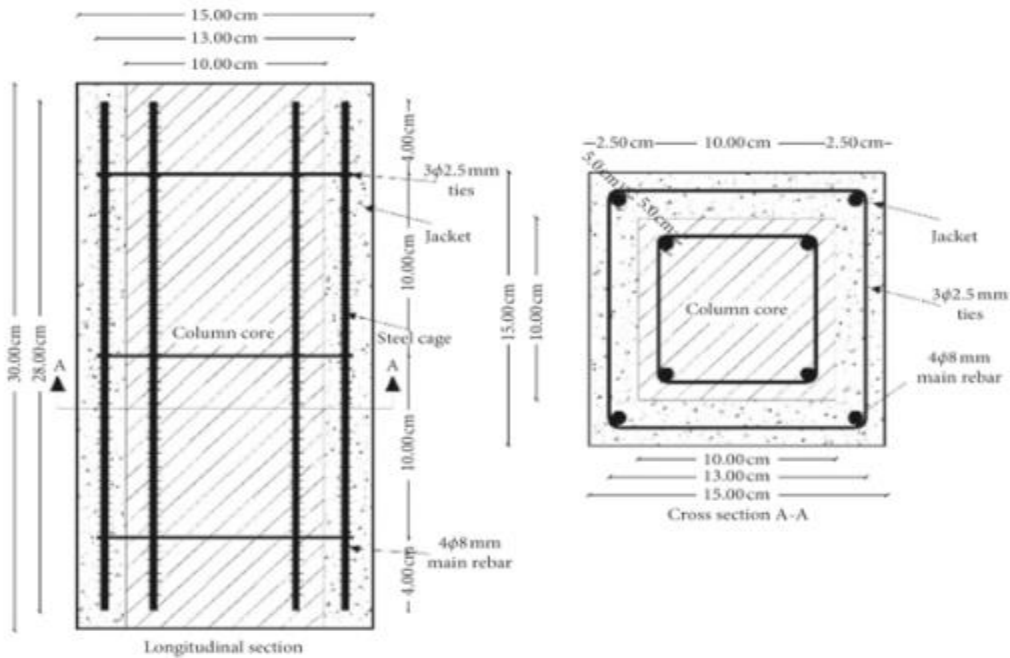

Figure 4.5: Geometry and reinforcement details of the experiment(Tayeh et al., 2019).



Figure 4.6: The A-B jacketed column specimens ready for testing(Tayeh et al., 2019).

The axial displacement of the specimens is measured using the compression testing machine. Three strain dial gauges with an accuracy of approximately 0.00254 mm are fixed at the mid-height of the column before testing. At each increment of 6kN axial compression load, the

readings of axial displacement are recorded using the machine data acquisition system. The value obtained from this experimental research where from the average of three specimens is 604mpa.

#### 4.2.2 Comparison of the Results

The results obtained from the laboratory test were used to compare with the results obtained from the finite element analysis. Hence, the finite element model was implemented based on the parameters and conditions used in the laboratory test. The load-deflection curve for both experimental and finite element analysis (ABAQUS Software package) has been presented in table 4.4.

Table 4.4: Comparison of experimental (Ammar, 2015) and finite element result

Type	Experimental result(KN)	Finite element result(KN)	Difference from Experimental result (%)	Reference
Concrete jacketing	604	592	0.67	(Tayeh <i>et al.</i> , 2019)
CFRP jacketing	743	738	0.5	(Krishna and Kumar, 2020)
Steel jacketing	554	554	2.53	(Ezz-eldeen, 2018)

The finite element model gives acceptable results for the ultimate load capacity with values less than 7% from the reference experimental values.

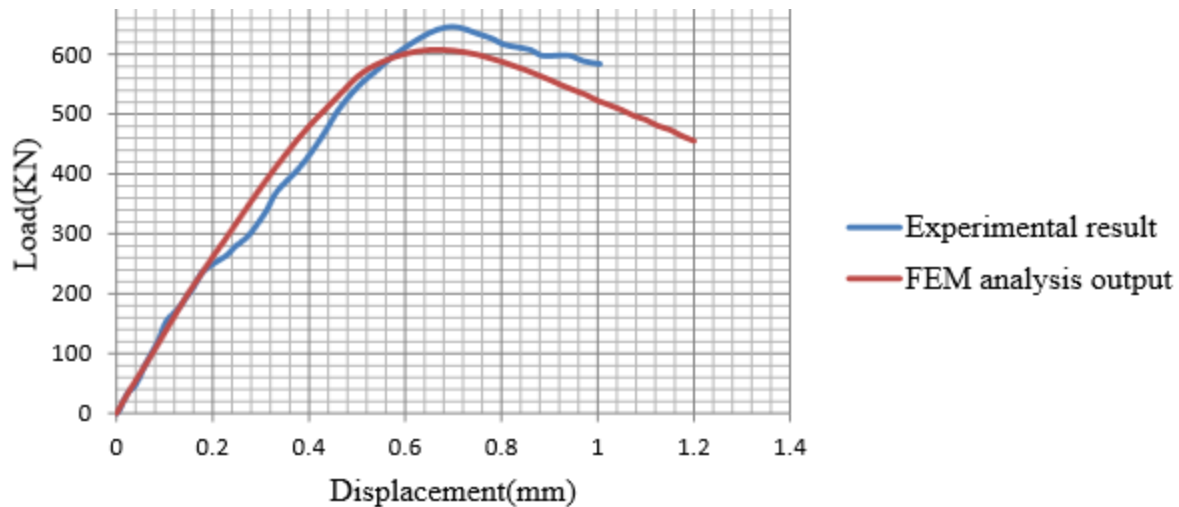

Figure 4.7: Comparison of experimental and finite element result

### 4.3 Effect of length

Column length greatly influences a column's ability to carry a load. Short columns fail by crushing due to material failure. Long, slender columns fail by buckling. Buckling is the sudden uncontrolled lateral displacement of a column at which point no additional load can be supported. Therefore, it is necessary to analyze the effect of jacketing methods as the length of columns varies. Figure 4.7 shows a slender column strengthened with reinforced concrete, CFRP, and steel. Figures, 4.7 and table 4.5 indicates the axial load-carrying capacity of reinforced concrete columns strengthened with RC jacketing has been improved by 32.1%, CFRP by 31.2%, and steel jacketed by 5.62% compared to the control columns (bare reinforced columns). As figure 4.8 and table 4.6 depicts for short RC jacketed columns strength increased by 36.5% which is the most efficient method of strengthening and followed by the CFRP jacketing technique with 16.8% axial load carrying capacity enhancement and the steel jacketing technique increased by 2.2% contrast to the bare reinforced concrete column.



Table 4.5: Axial load capacity of a retrofitted slender column

Type	Length(mm)	Ultimate load	% Increase for bare column
Bare RC column	3650	564.5	0
CFRP jacketed column	3650	598.1	5.62
Steel jacketed column	3650	820.7	31.22
RC jacketed column	3650	831.52	32.1

Table 4.6: Axial load capacity of retrofitted short column

Type	Length(mm)	Ultimate load	Increase for bare column (%)
Bare RC column	1200	612.2	0
CFRP jacketed column	1200	736	16.8
Steel jacketed column	1200	625.8	2.2
RC jacketed column	1200	964.1	36.5

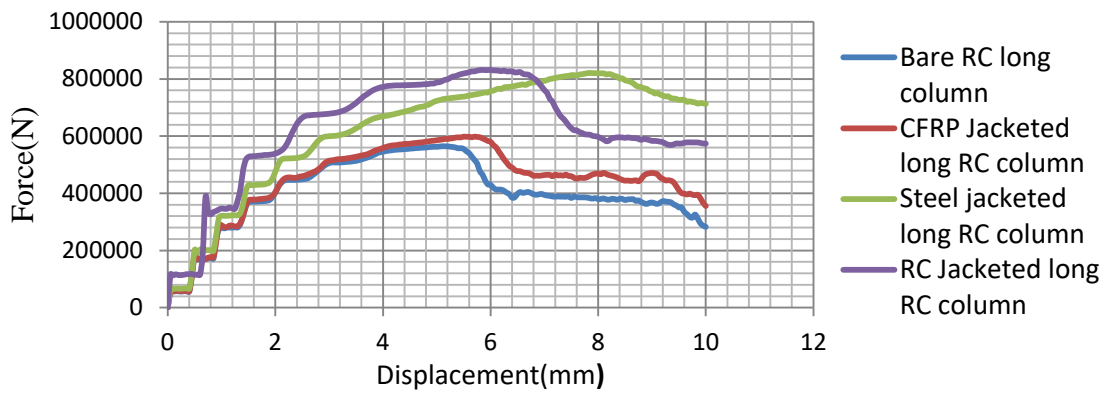

Figure 4.8: Effect of length for long column

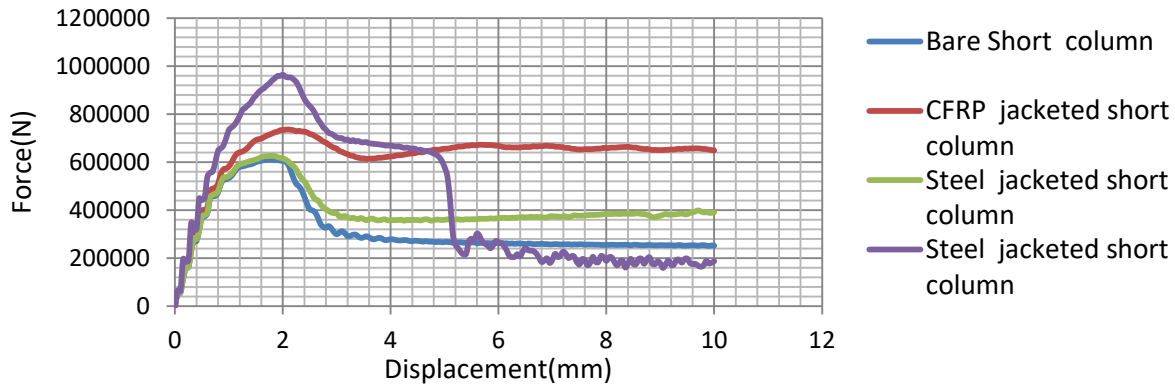

Figure 4.9: Effect of length for short column

#### 4.4 Effect of eccentricity

Eccentrically loaded columns are subjected to moment, in addition to axial force. The moment can be uniaxial, as in the case when two adjacent panels are not similarly loaded. Biaxial bending of columns occurs when the loading causes bending simultaneously about both principal axes. To study the performance of a strengthened RC column both Uni-directional and Bi-directional load eccentricities are considered.

##### 4.4.1 Uni-Directional Eccentricity

The capacity for different values of eccentric was obtained from FEM analysis. Displacement eccentric loading was applied on a loading plate 50mm thick with 20mm, 35mm, and 45mm eccentricity, and the force-displacement response is drawn for each eccentric loading jacketed column. The ultimate loading capacity was obtained from the outputs of the FEM analysis.

The force to displacement curve in Figures(4.9,4.11,14) and table 4.7 assures that for uni-directional eccentrically loaded strengthened slender reinforced concrete column RC jacketing technique shows better improvements in ultimate load carrying capacity by 33% for 20mm eccentricity, 34% for 35mm eccentricity and 35.74% for 45mm eccentric loading. Next to reinforced concrete jacketing steel strengthening technique enhanced the ultimate load-carrying

capacity by 32% for 20mm eccentric loading, 29.15% for 35mm load eccentricity, and 30.78% for 45mm eccentricity. CFRP jacketing holds the third rank in improving the capacity of the eccentrically loaded column. As the eccentricity length of the load increase, the steel jacketing technique will be a good alternative to use next to the reinforced jacketing technique. Figure (4.10, 4.12, 4.13) and table 4.4 strengthened short column loaded with uni-axial eccentric loading showed that reinforced concrete jacketing raise the axial load carrying capacity with 33.32% when the eccentricity length is 20mm, 34.93% for 35mm eccentricity and 36.33% 45mm eccentricity, and followed by CFRP jacketing and lastly steel jacketing.

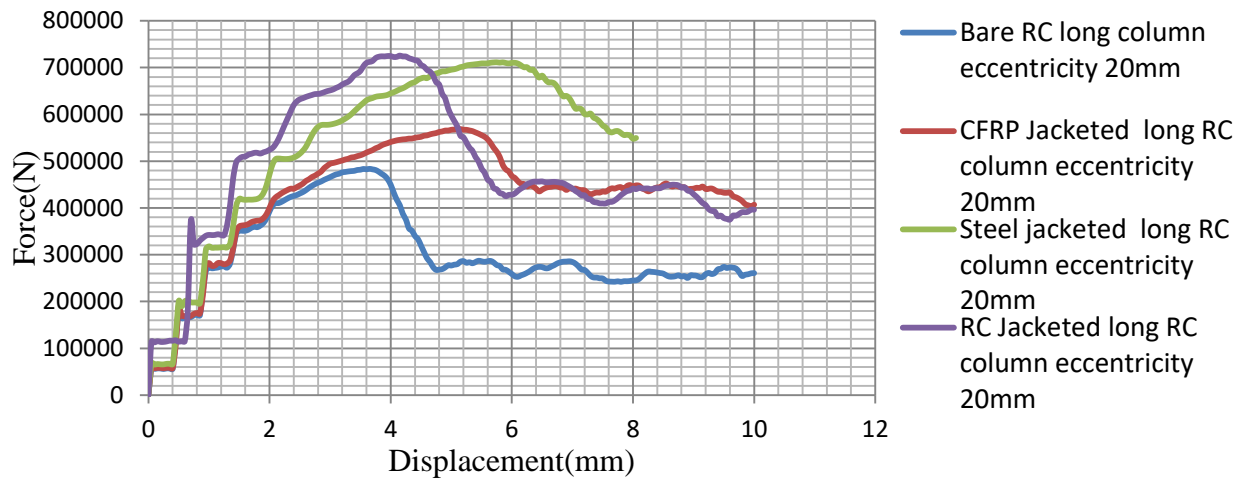

Figure 4.10: Comparison of the efficiency of uni-directionally loaded strengthened slender column with an eccentricity of 20mm.

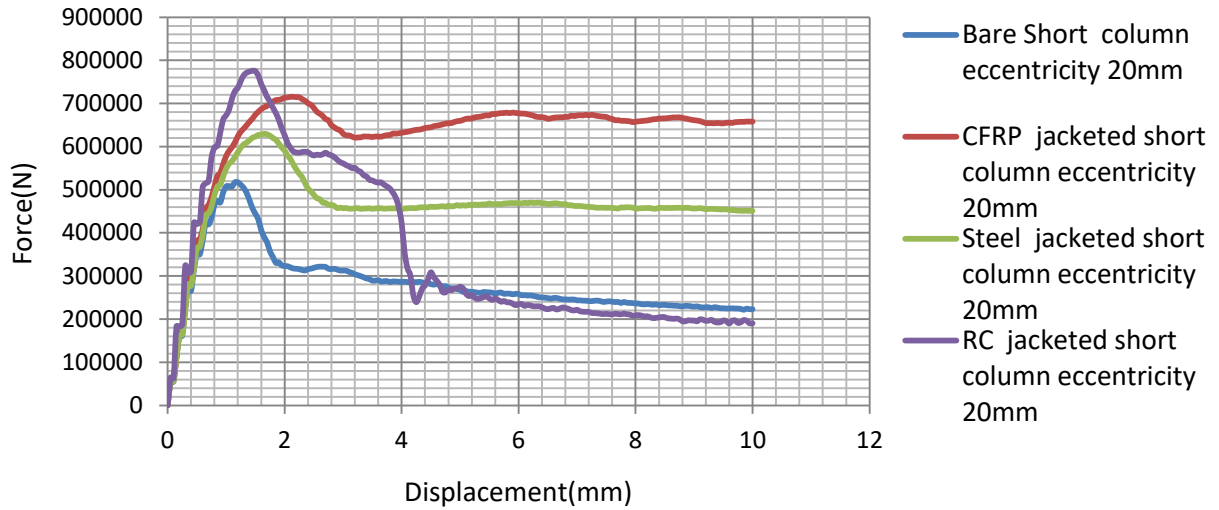

Figure 4.11: Comparison of the efficiency of uni-directionally loaded strengthened short column with an eccentricity of 20mm.

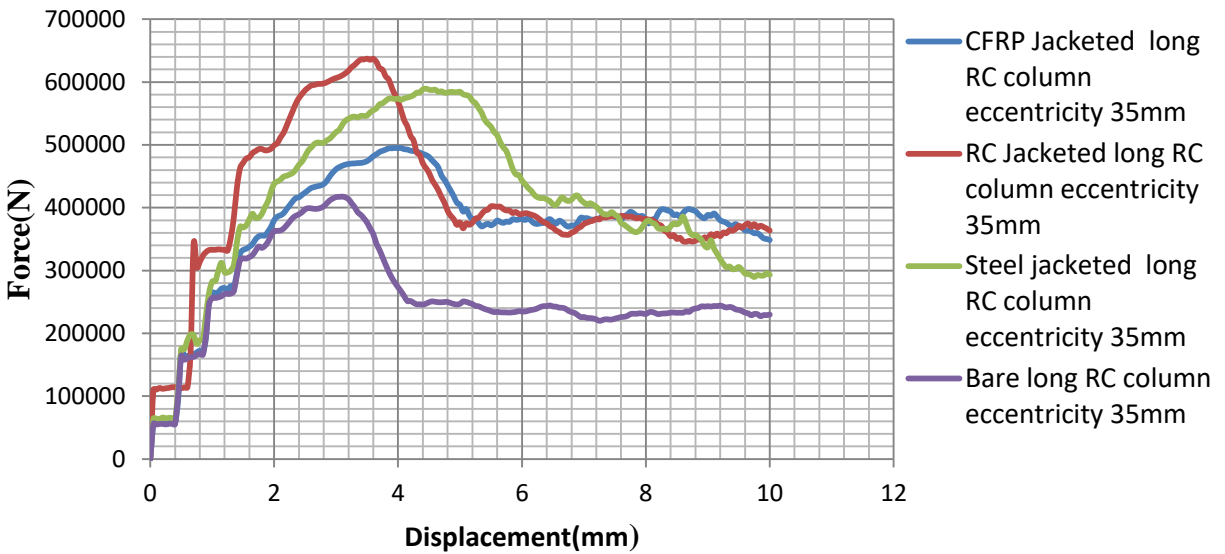

Figure 4.12: Comparison of the efficiency of uni-directionally loaded strengthened slender column with an eccentricity of 35mm.

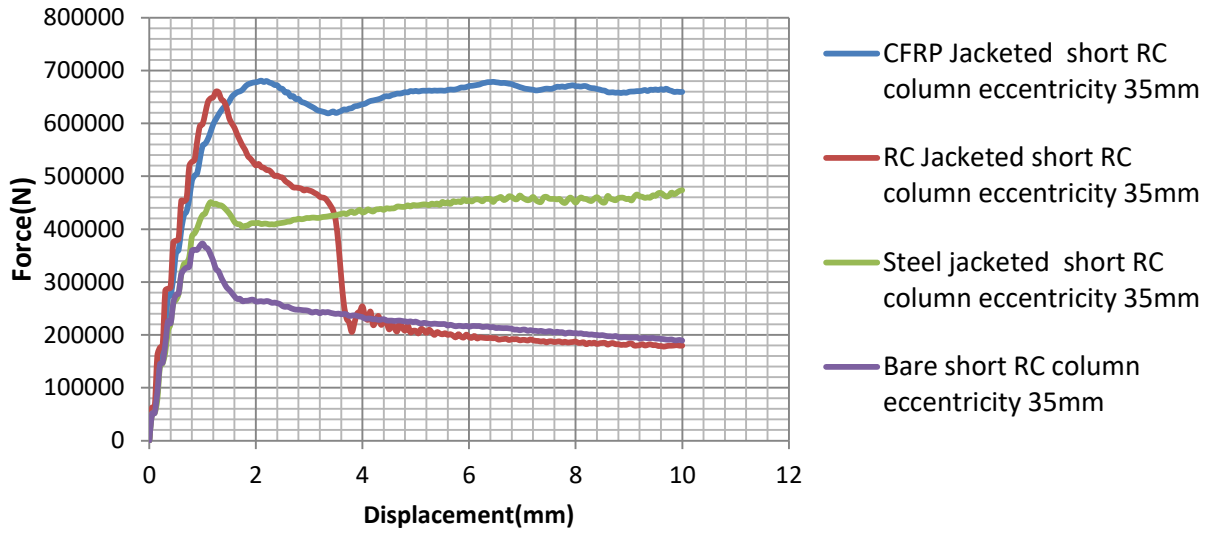

Figure 4.13: Comparison of the efficiency of uni-directionally loaded strengthened short column with an eccentricity of 35mm.

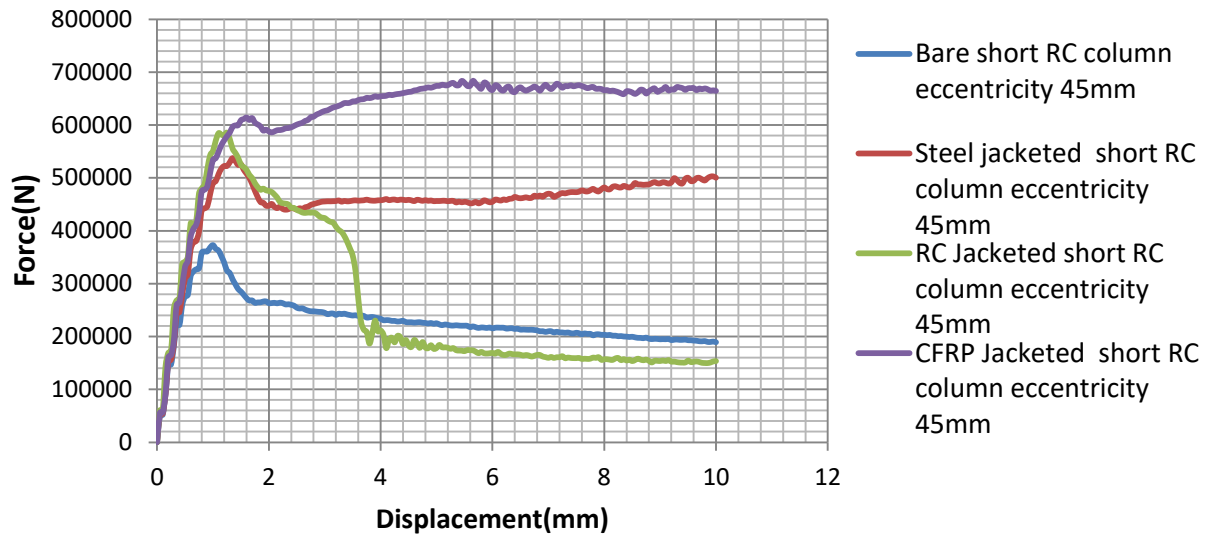

Figure 4.14: Comparison of the efficiency of uni-directionally loaded strengthened short column with an eccentricity of 45mm

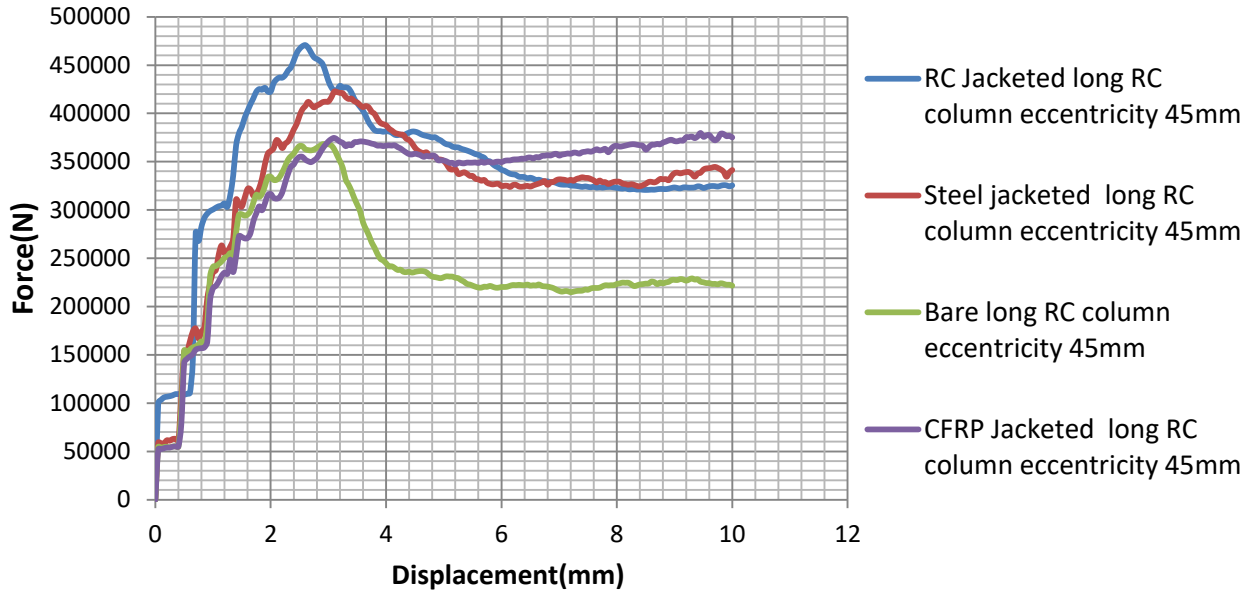

Figure 4.15: Comparison of the efficiency of uni-directionally loaded strengthened slender RC column with an eccentricity of 45mm.

Table 4.7: Results for Uni-directional Eccentricity for Bare and Retrofitted Slender RC Columns.

Eccentricity	Ultimate load(KN)				The increase compared to the bare column (%)		
	Bare frame	CFRP jacketed frame	steel jacketed frame	RC jacketed frame	CFRP	steel	RC jacketed frame
20	483.6	676.79	711.3	725.6	28.55	32	33.4
35	417.64	495.06	589.44	637.21	25.73	29.15	34.5
45	368.12	449.87	531.85	572.9	18.2	30.78	35.74

Table 4.8: Results for un-directional eccentricity for bare and retrofitted short RC columns.

Eccentricity (mm)	Ultimate load (KN)				The increase compared to the bare column (%)		
	Bare frame	CFRP jacketed frame	Steel jacketed frame	RC jacketed frame	CFRP	Steel	RC jacketed frame
20	517.34	715.4	629.5	775.8	27.7	17.82	33.32
35	429.46	680.79	577.97	660	15.6	25.7	34.93
45	372.83	583.59	537.46	585.58	36.46	30.63	36.33

#### 4.4.2 Bi-directional eccentricity

In column members, it is common to find a bi-directional eccentricity ( $e_x$  &  $e_z$ ). The FEM analysis gives the maximum load-carrying capacity for different values of combined eccentricity. The increase of load carrying capacity of a reinforced concrete column with the three techniques of jacketing loaded with bi-directional eccentricity is shown in Tables 4.9 and figure (4.15,4.17 and 4.18) for slender columns and Tables 4.10 and figure (4.16,4.19 4.20) for a short column. The load-carrying capacity of the reinforced concrete jacketed column loaded with a bi-directional eccentricity of 20mm enhanced by 52.4%, steel jacketed by 27.92%, and CFRP jacketed column by 16.02% compared to the bare column for the slender column. As table 4.10 reveals when the length of eccentricity increase CFRP jacketing perform well relatively for the slender column, for less eccentricity reinforced concrete jacketing gives a better axial load resistance. For 45mm eccentricity, CFRP jacketing gives a 60.2% increase in axial load carrying capacity, reinforced concrete jacketing 40.9%, and steel 30.63% contrast to the bare frame.

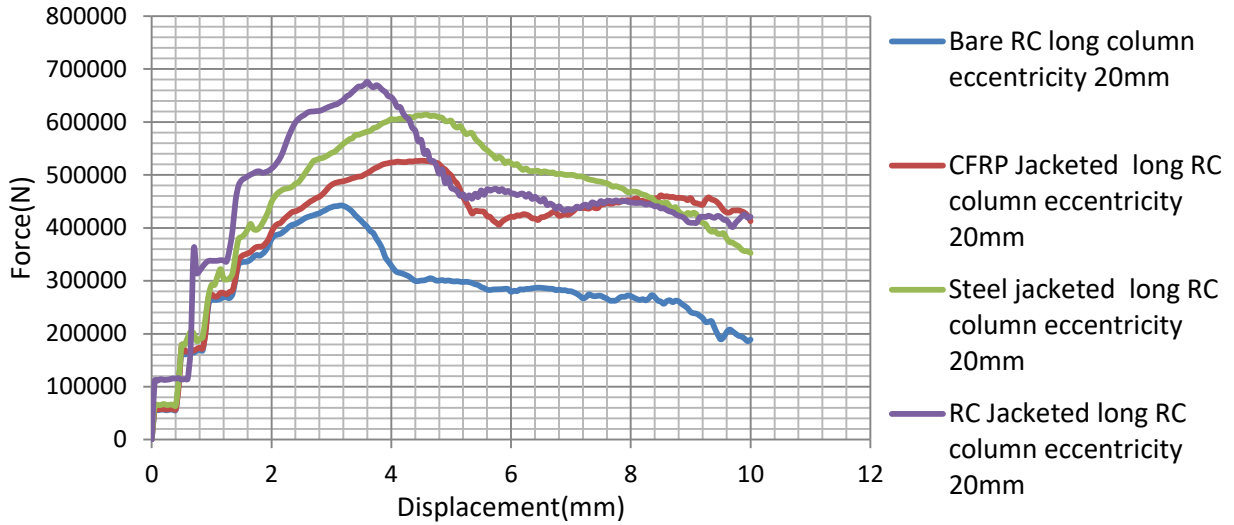

Figure 4.16: Comparison of the efficiency of bi-directionally loaded strengthened slender RC column with an eccentricity of 20mm.

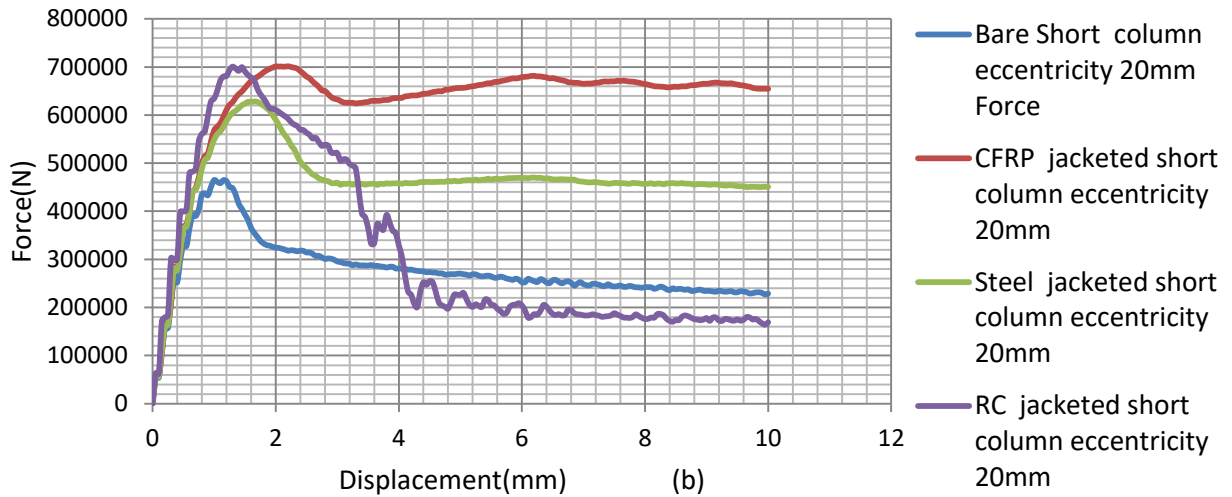

Figure 4.17: Comparison of the efficiency of bi-directionally loaded strengthened short RC column with an eccentricity of 20mm.



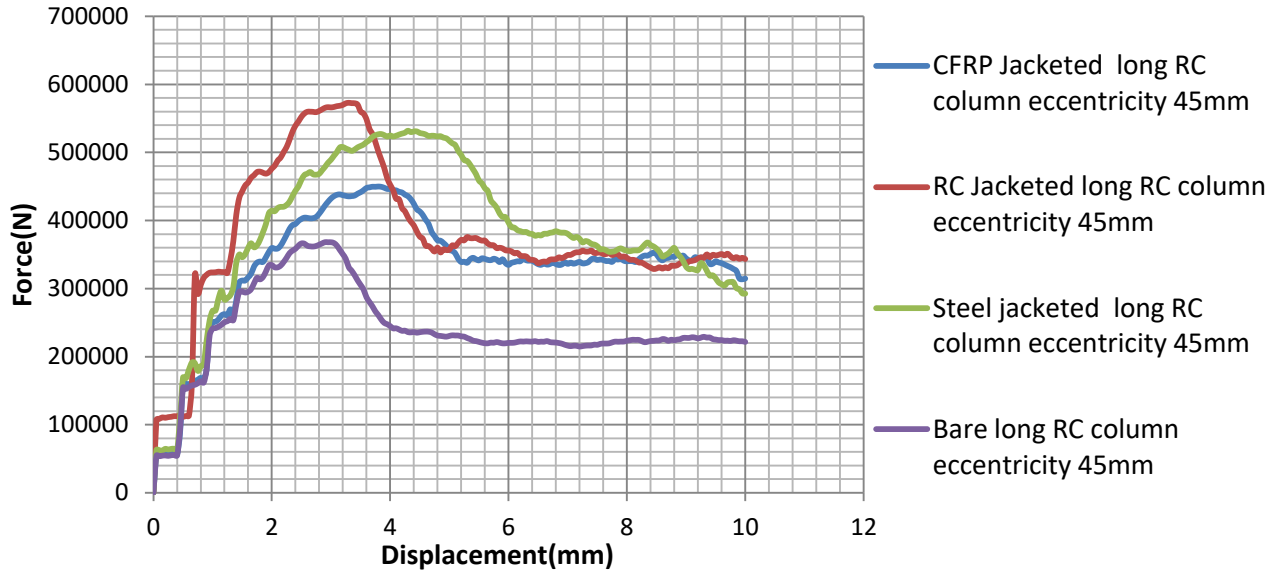

Figure 4.18: Comparison of the efficiency of bi-directionally loaded strengthened slender RC column with an eccentricity of 45mm.

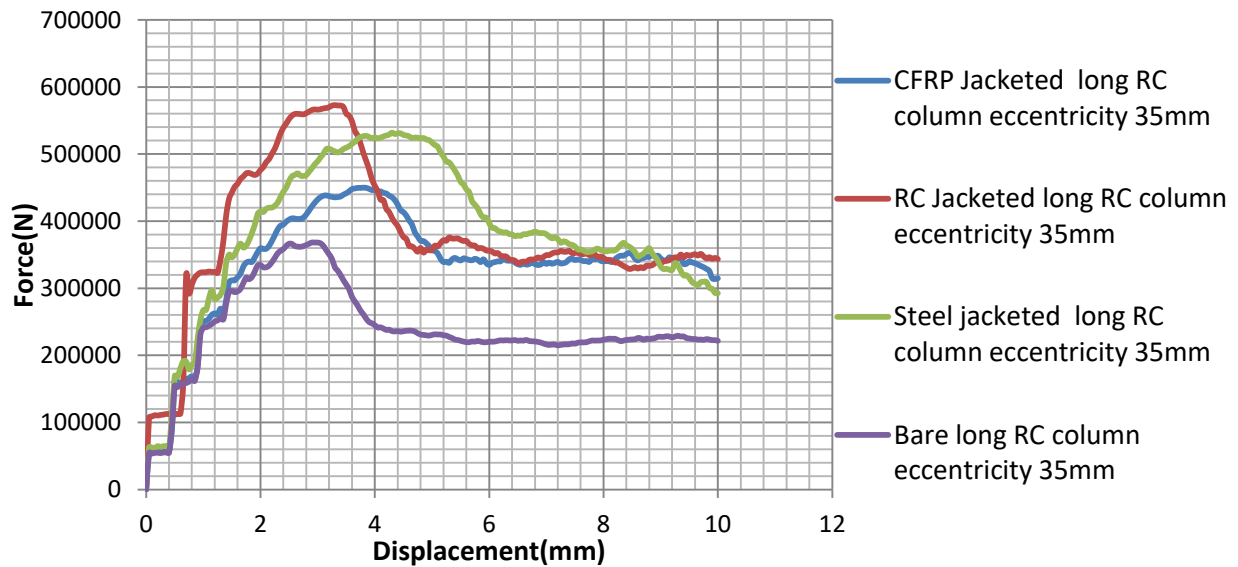

Figure 4.19: Comparison of the efficiency of bi-directionally loaded strengthened slender RC column with an eccentricity of 35mm.

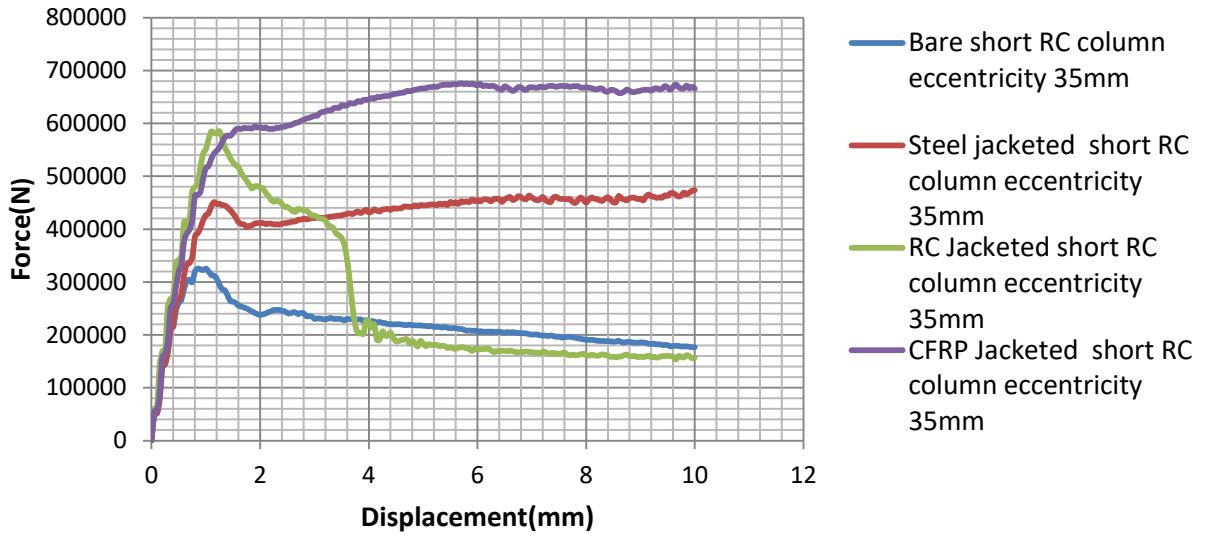

Figure 4.20: Comparison of the efficiency of bi-directionally loaded strengthened short RC column with an eccentricity of 35mm.

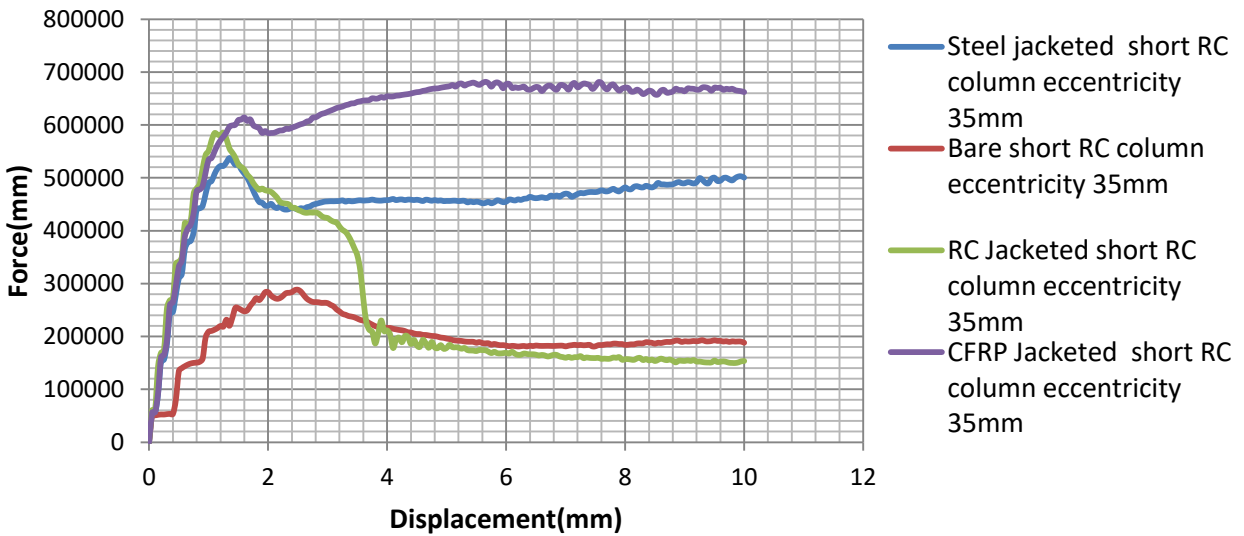

Figure 4.21: Comparison of the efficiency of bi-directionally loaded strengthened short RC column with an eccentricity of 35mm.

Values for reference and strengthened columns under Bi directional eccentricities are given below.

Table 4.9: Results for Bi-directional eccentricity for bare and retrofitted slender RC columns.

Eccentricity	Ultimate load(KN)				The increase compared to the bare column (%)		
	Bare frame	CFRP jacketed frame	steel jacketed frame	RC jacketed frame	CFRP	steel	RC jacketed frame
20	442.45	526.9	613.8	676	16.02	27.92	52.4
35	315.97	468.2	486.9	536.55	32.5	35.11	41.11
45	282.27	427.83	413.36	462.42	34	31.71	38.96

Table 4.10: Results for bi-directional eccentricity for bare and retrofitted short RC columns.

Eccentricity	Ultimate load (KN)				The increase compared to the bare column (%)		
	Bare frame	CFRP jacketed frame	Steel jacketed frame	RC jacketed frame	CFRP	Steel	RC jacketed frame
20	464.9	701.4	628.2	702	33.72	17.82	33.8
35	298.36	670.94	488.32	525.76	55.53	25.7	43.25
45	265.9	668.00	475.4	449.94	60.2	30.63	40.9

#### 4.5 Story Displacement

Figure (4.21- 4.27) and table 4.11 shows the numerical result of the finite element analysis of story displacement vs time of strengthened columns using reinforced concrete, CFRP, and steel jacketing is presented. As table 4.11 results show the reinforced concrete jacketed column gives a greater decrease in story displacement by 40.6% for the top floors and next steel jacketing showed a decrease in story displacement by 27.37% and CFRP jacketed column decreased by

16.8% in story displacement relative to the control RC frame. Hence, RC jacketing has been found the most efficient in terms of story displacement reduction of the three jacketing techniques considered in this study. For further information see table 4.11.

Based on (ESA, 2015) the allowable lateral displacement for a structure having non-structural elements of brittle materials attached to the structure is limited to  $H/200$  where  $H$  is the height of the structure so in this case by considering of height of the structure which is equal to 21 meters the allowable lateral displacement becomes 105mm.

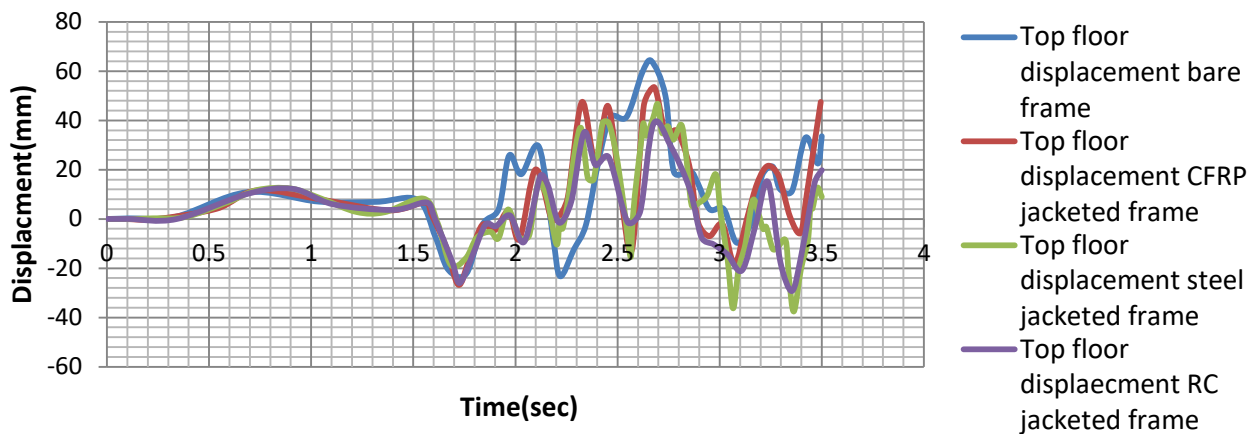

Figure 4.22: Maximum Story Displacement comparison of bare, CFRP, steel and RC jacketed frame for the top floor.

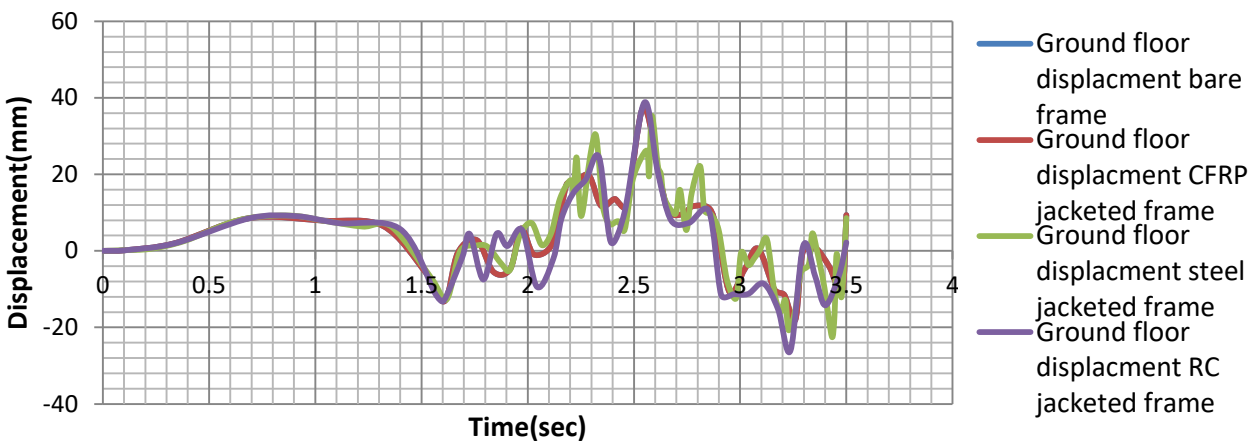

Figure 4.23: Maximum Story Displacement comparison of bare, CFRP, steel, and RC jacketed frame for ground frame.

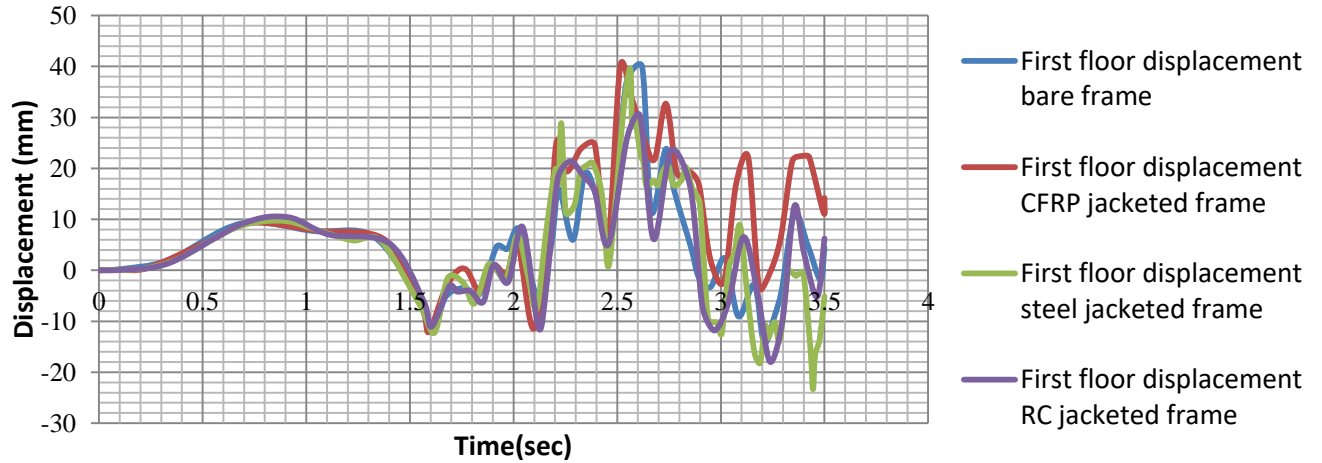

Figure 4.24: Maximum Story Displacement comparison of bare, CFRP, steel and RC jacketed frame for the first floor.

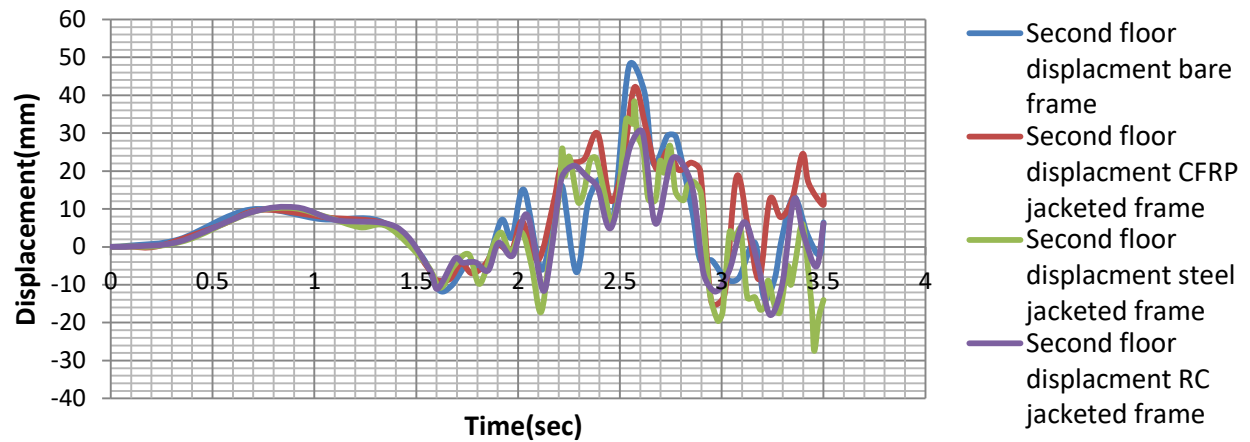

Figure 4.25: Maximum Story Displacement comparison of bare, CFRP, steel and RC jacketed frame for the second floor.

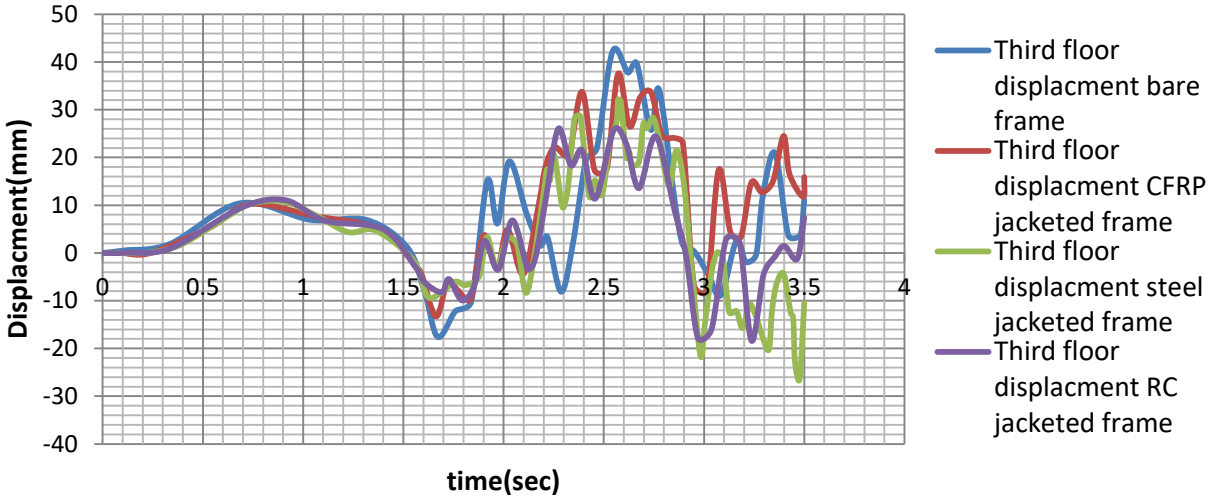

Figure 4.26: Maximum Story Displacement comparison of bare, CFRP, steel and RC jacketed frame for the third floor.

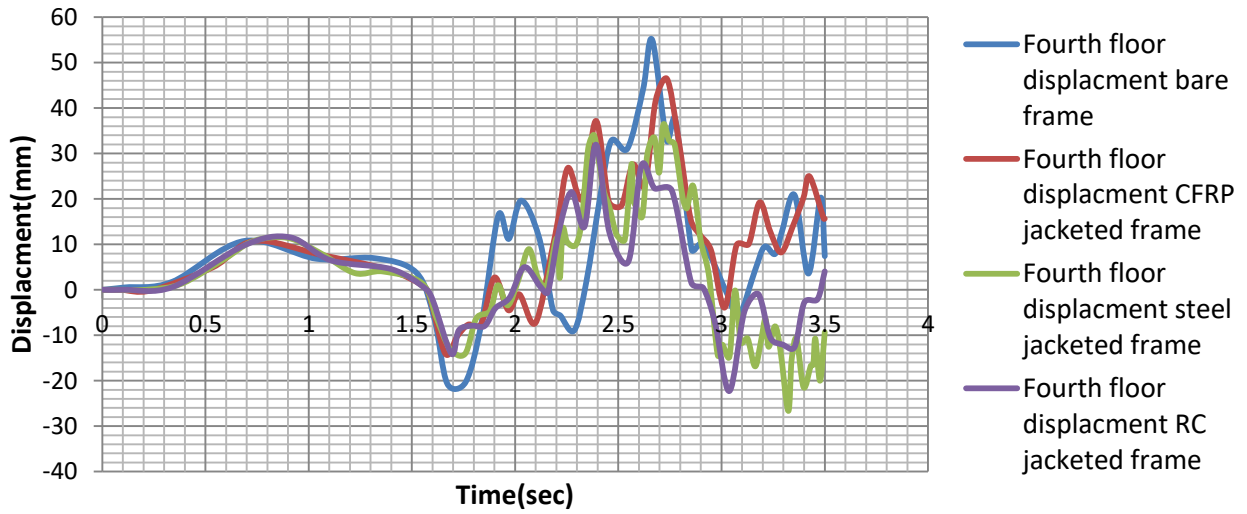

Figure 4.27: Maximum Story Displacement comparison of bare, CFRP, steel and RC jacketed frame for the fourth floor.

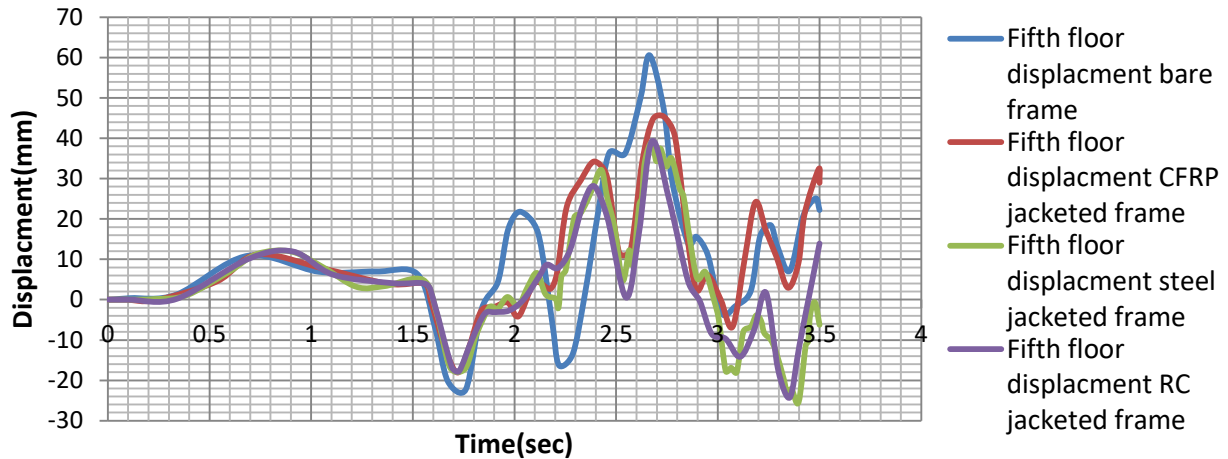

Figure 4.28 Maximum Story Displacement comparison of bare, CFRP, steel and RC jacketed frame for the fifth floor.

Generally, the following table 4.11 compares the reduction of -story displacement in percentage as compared to the bare frame for the three retrofitting systems considered in this study.

Table 4.11: Summary story displacement results in percent of retrofitted RC frame

Story	Bare frame	CFRP jacketed frame	steel jacketed frame	RC jacketed frame	Reduction of story displacement (%)		
					CFRP	steel	RC
Top	64.3	53.5	46.7	38.5	16.8	27.37	40.6
Ground	38.7	37.5	35.3	34.9	3.1	8.8	10.6
1st	40.1	39.51	39.6	30.2	1.5	1.25	24.7
2nd	47.5	42.1	38.4	30.2	11.4	19.16	36.4
3rd	42.3	37.5	32.2	26.1	11.35	23.88	38.3
4th	55	46.4	46.4	36.3	15.64	15.64	34
5th	60.6	45.3	39.2	39.1	25.25	35.31	35.5

#### 4.6 Story drift

The story drift versus time curve shown in figure 4.4-figure 4.9 and Table 4.5 point out that the maximum reduction in story drift is found when the bare frame is jacketed with reinforced concrete and followed by a steel jacketed frame. For the top story, the reduction in story drift for

the reinforced concrete jacketed column is 39%, steel jacketed 36.3% and CFRP jacketed 12.1%. In the first story, the reinforced concrete jacketed frames story drift decreased by 51%, steel jacketed by 40.5% and CFRP decreased by 32.68%. Hence, reinforced concrete jacketing is found the most efficient in terms of story drift reduction from retrofitting techniques considered in this study.

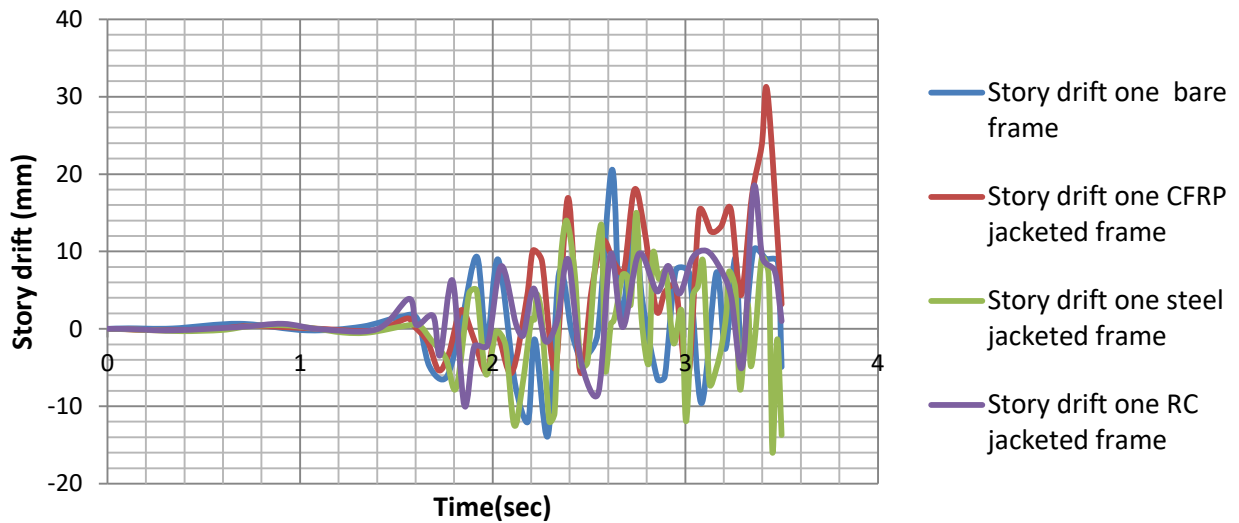

Figure 4.29: Maximum Story drift comparison of bare, CFRP, steel, and RC jacketed frame for story one

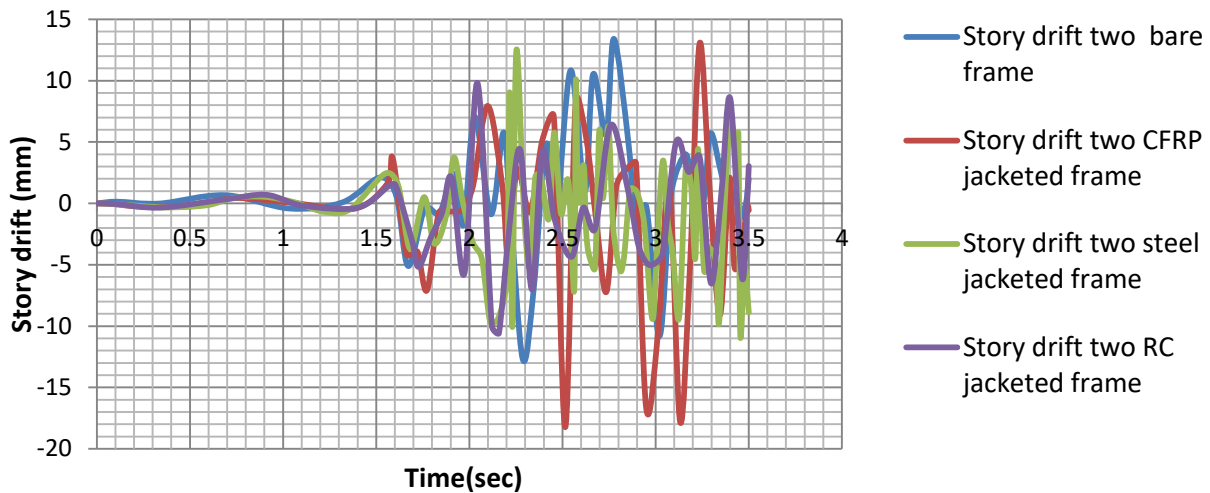

Figure 4.30: Maximum Story drift comparison of bare, CFRP, steel, and RC jacketed frame for story two.



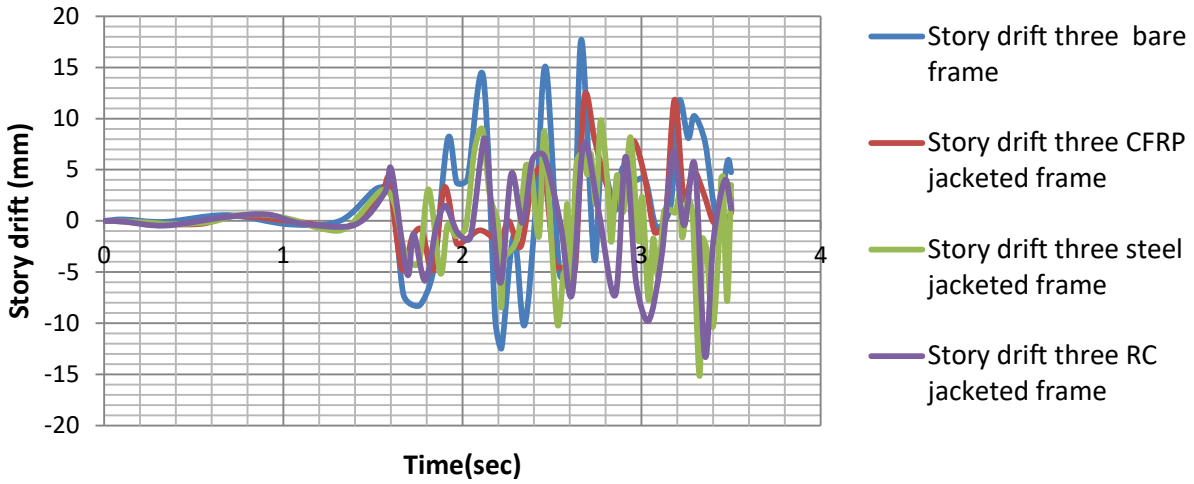

Figure 4.31 Maximum Story drift comparison of bare, CFRP, steel, and RC jacketed frame for story three.

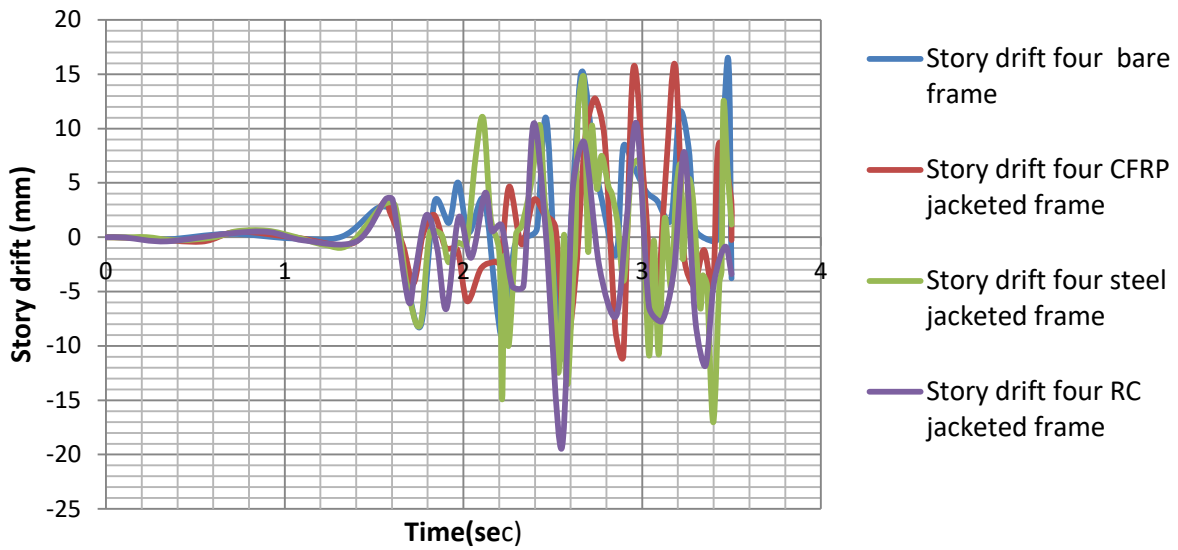

Figure 4.32 Maximum Story drift comparison of bare, CFRP, steel, and RC jacketed frame for story four.

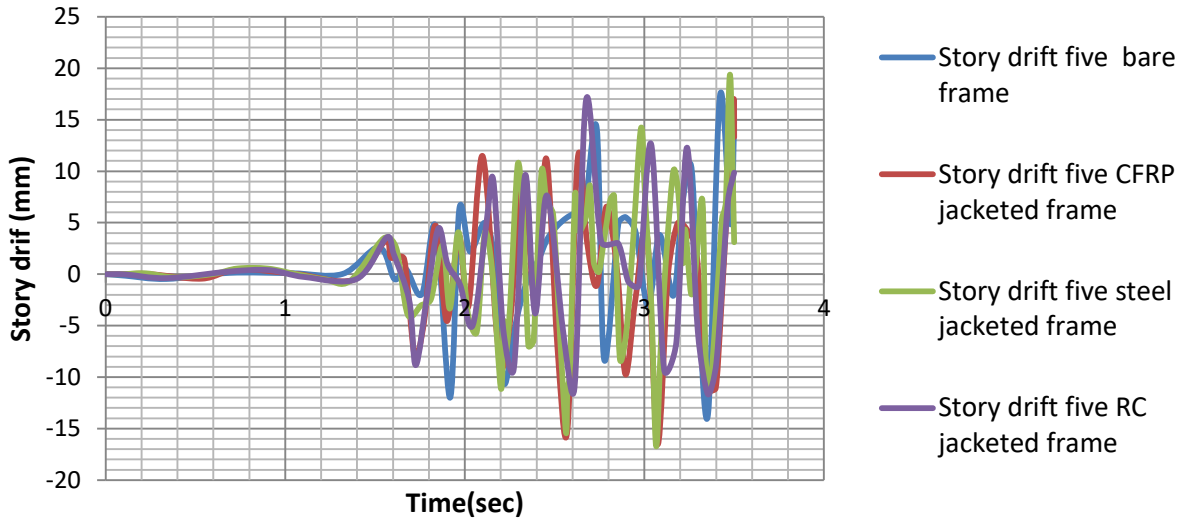

Figure 4.33: Maximum Story drift comparison of bare, CFRP, steel, and RC jacketed frame for story five.

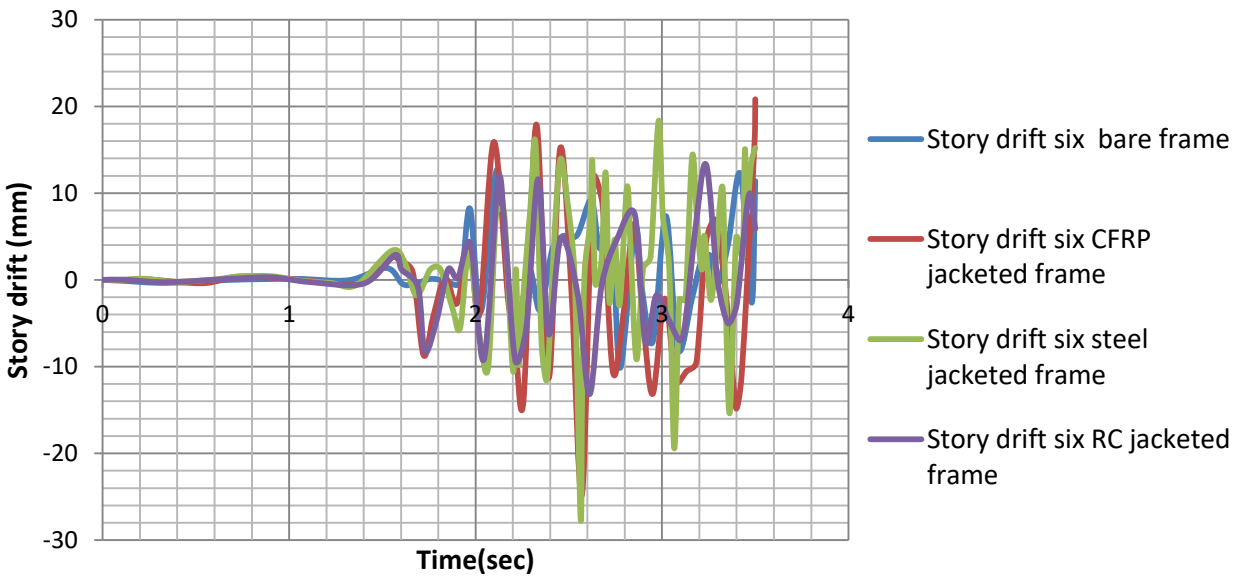

Figure 4.34: Maximum Story drift comparison of bare, CFRP, steel, and RC jacketed frame story for six.

Generally, the following table compares the reduction of story drift in percentage as compared to the bare frame for the different lateral load-resisting systems considered in this study.

Table 4.12: Percentage reductions in maximum story drift of different lateral load resisting systems compared to the bare frame.

Story	Bare frame	CFRP jacketed frame	steel jacketed frame	RC jacketed frame	Reduction in story drift compared to the bare frame (%)		
					CFRP	steel	RC
Top	20.82	18.3	13.27	12.71	12.1	36.3	39
1st	30.57	20.58	18.2	15	32.68	40.5	51
2nd	13.41	13.03	12.44	9.8	2.83	7.2	26.9
3rd	17.71	12.03	9.84	8.03	32.1	44.44	54.7
4th	16.5	15.83	14.51	10.41	4.1	12.1	37
5th	19.36	17.24	16.94	16.44	10.95	12.5	15.01

According to (ESA, 2015) inter-story drift is evaluated as the difference in the average lateral displacements  $d_s$  at the top and bottom of the story under consideration. For buildings having non-structural elements of brittle materials attached to the structure of the code provide the following inter-story drift limit

$$dr \cdot v \leq 0.005h$$

Where  $dr$  is the design inter-story drift and  $h$  is the story height  $v$  is the reduction factor which takes into account the lower return period of the seismic load associated with the damage limitation requirement. The recommended values of  $v$  are 0.4 for importance classes III and IV and  $v = 0.5$  for importance classes I and II. Therefore, the drift limitation for the study will be

$$dr \leq 0.005h/0.4=0.0125h$$

Based on the above criteria, for all models considered in the study, story drift values are within the permissible limit.

#### 4.7 Story drift ratio

The drift ratio is defined as the difference in horizontal displacement over one Story (floor) divided by the story height.

As seen in Table 4.13 the top floor drift ratio decreased by 38.2% for CFRP jacketed frame, 36.5% for reinforced concrete jacketing, and 12.04% for steel jacketing techniques compared to the bare frame. On the first floor, the steel jacketed columns drift ratio decreased by 51%, reinforced concrete jacketed columns decreased by 41.64% and CFRP jacketed columns decreased by 33.33%. On average reinforced concrete jacketing is the most efficient technique of retrofitting for drift ratio reduction.

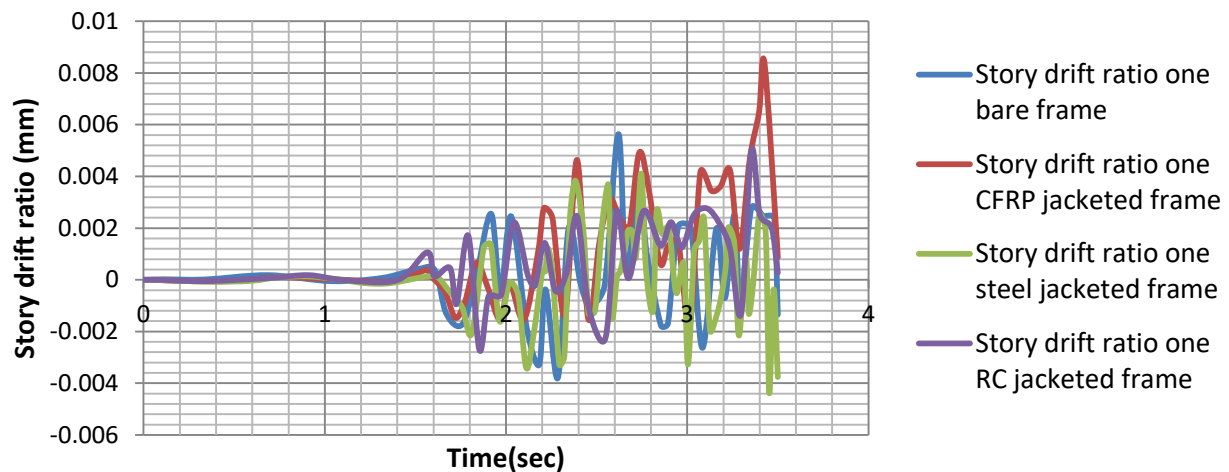

Figure 4.35: Maximum Story drift ratio comparison of bare, CFRP, steel, and RC jacketed frame for story one

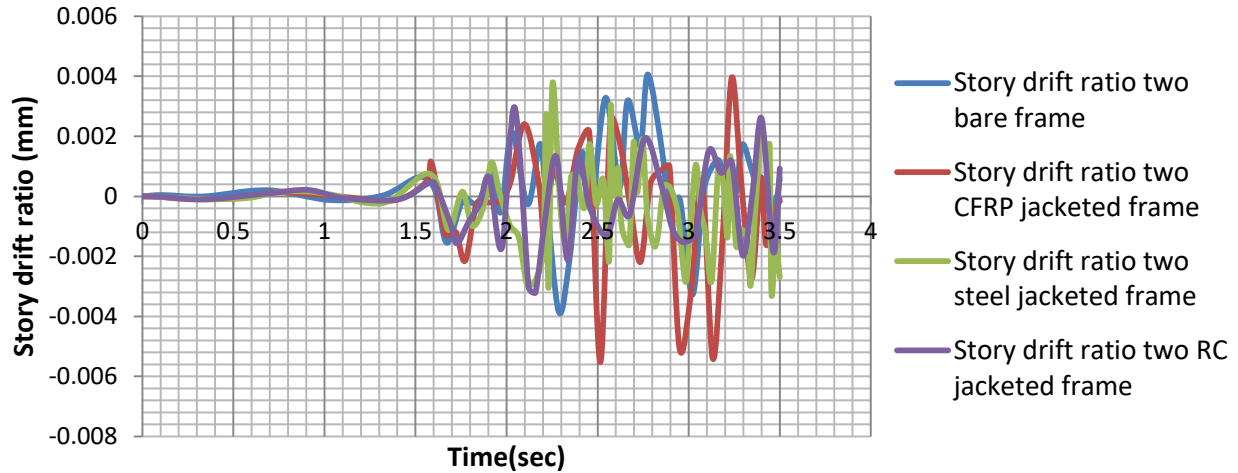

Figure 4.36: Maximum Story drift ratio comparison of bare, CFRP, steel, and RC jacketed frame for story two.

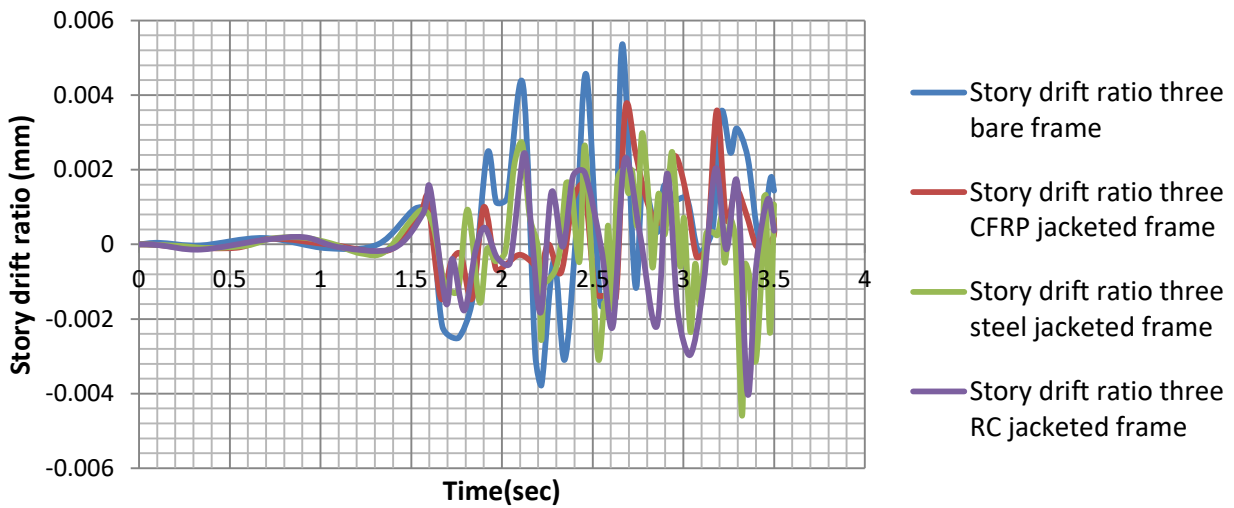

Figure 4.37: Maximum Story drift ratio comparison of bare, CFRP, steel, and RC jacketed frame for story three

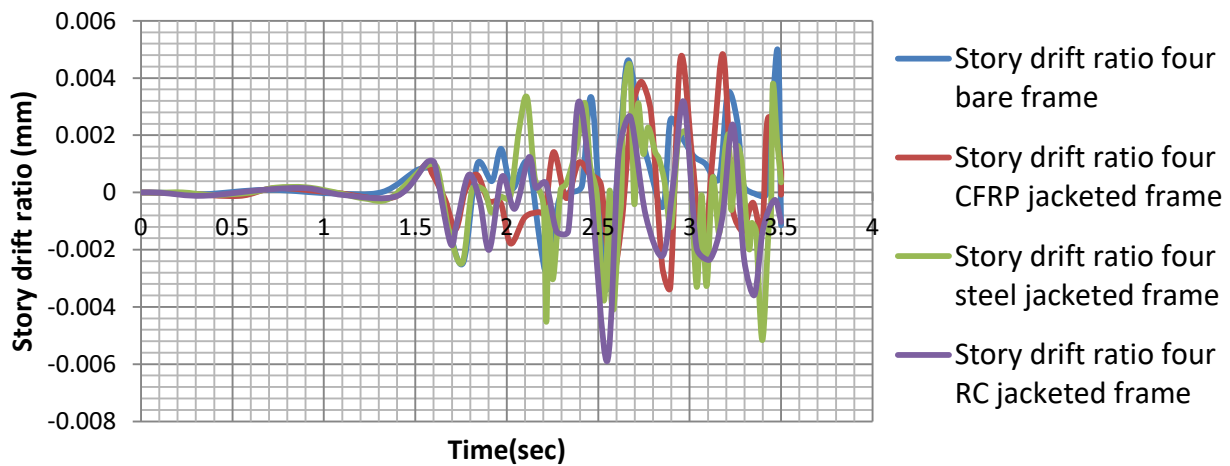

Figure 4.38: Maximum Story drift ratio comparison of bare, CFRP, steel, and RC jacketed frame story four.

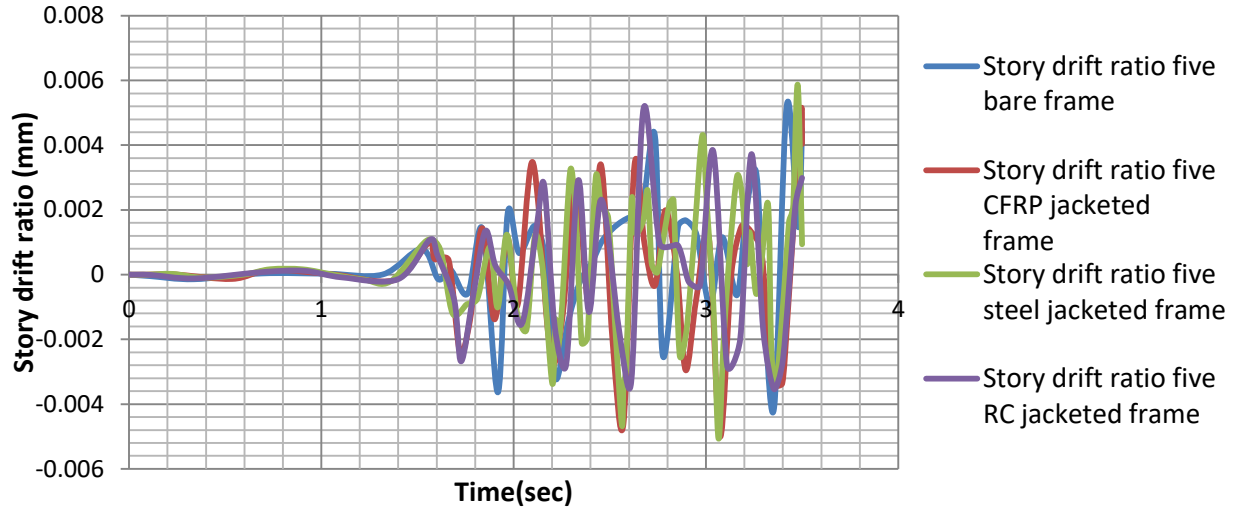

Figure 4.39: Maximum Story drift ratio comparison of bare, CFRP, steel, and RC jacketed frame for story five

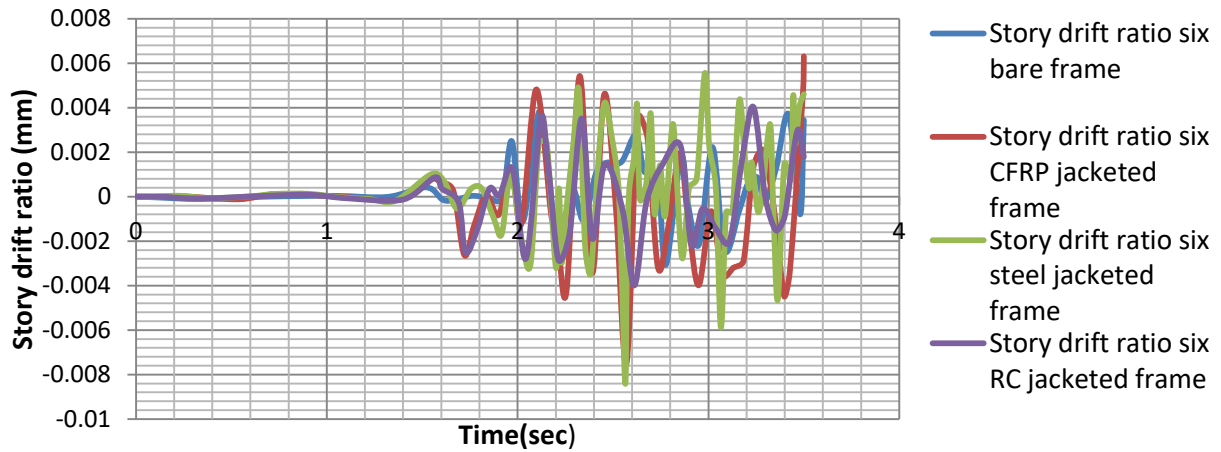

Figure 4.40: Maximum Story drift ratio comparison of bare, CFRP, steel, and RC jacketed frame for story six.

Table 4.13: Percentage reductions in maximum story drift ratio of different lateral load resisting systems compared to the bare frame.

Story	Bare frame	CFRP jacketed frame	steel jacketed frame	RC jacketed frame	Reduction in drift ratio compared to a bare frame (%)		
					CFRP	steel	RC
Top	0.0063	0.0039	0.0055	0.004	38.2	12.04	36.51
1st	0.0084	0.0056	0.0041	0.0049	33.33	51.2	41.67
2nd	0.0041	0.0039	0.0037	0.0029	10.98	8.04	29.3
3rd	0.0054	0.0036	0.0029	0.0024	32.41	44.8	55.6
4th	0.005	0.0048	0.0043	0.0031	4	14	38
5th	0.0059	0.005	0.0052	0.0051	14.51	11.9	13.6

#### 4.8 Failure modes of columns from the FE analysis

Figure 4.41 show that failure on the Short RC jacketed column occurred at the upper edge of the middle height of the column by crushing or yielding the materials. Both the concrete column and RC jacketing materials failed at the same time. A shorter and wider column normally fails under compression failure when the axially loaded stress exceeds allowable stress. From Figure 4.42 and Figure-4.43, the steel and CFRP jacketed column have the same failure mode as RC jacketed short column, as the concrete material bulge the stress on the steel and CFRP jacketing to increases and cause the yielding of the steel straps and cracking of CFRP that leads to failure of the column. From Figure 4.44 - 4.46, the failure mode for long RC, steel, and CFRP jacketed columns is buckling. As the vertical load increases the bending stress also increases that leading to bending failure in the middle of the columns.

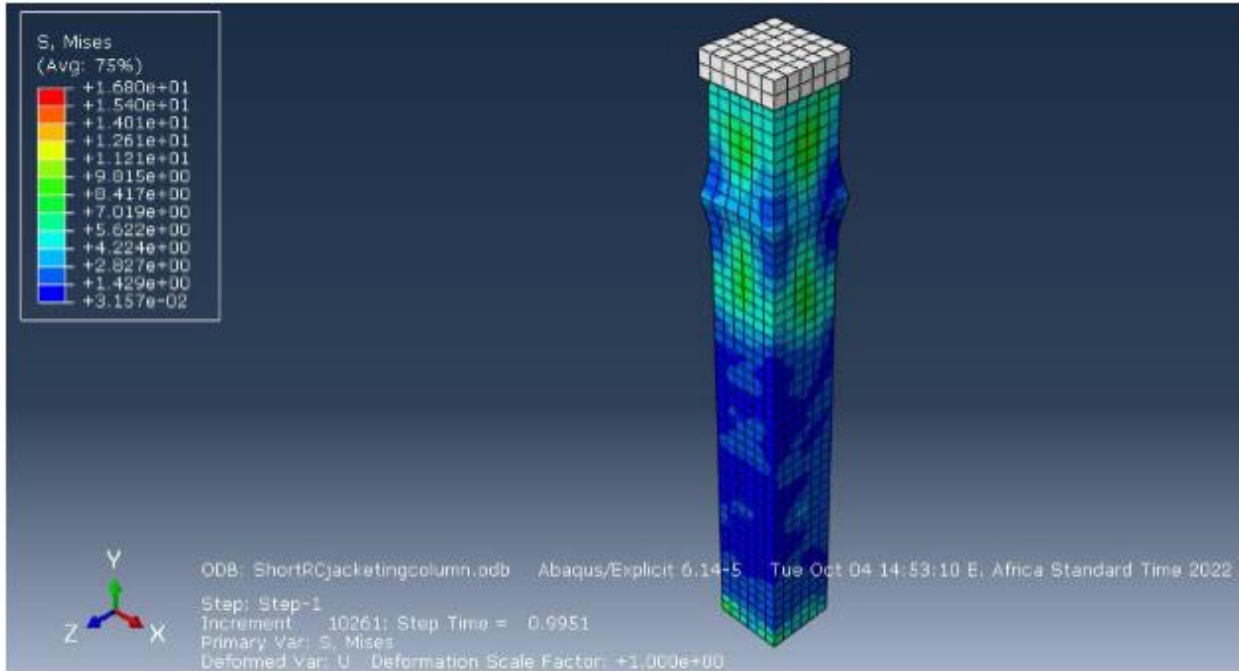

Figure 4.41: Failure mode of short RC jacketed column.

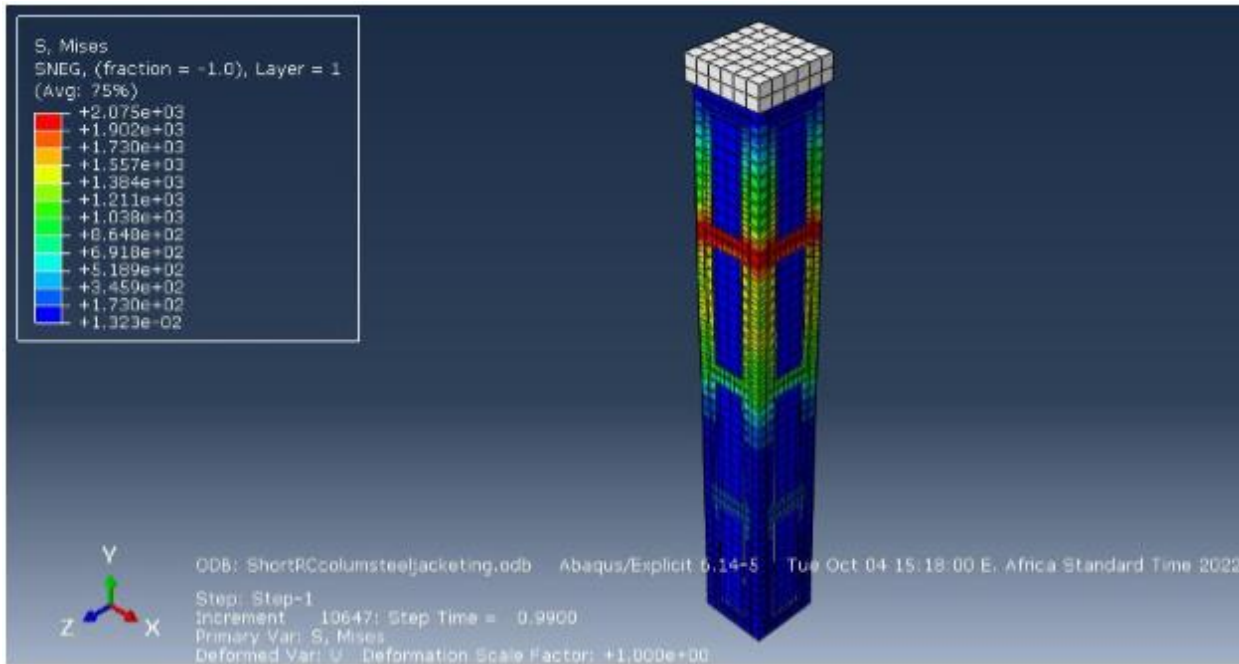

Figure 4.42: Failure mode of steel jacketed reinforced concrete column.



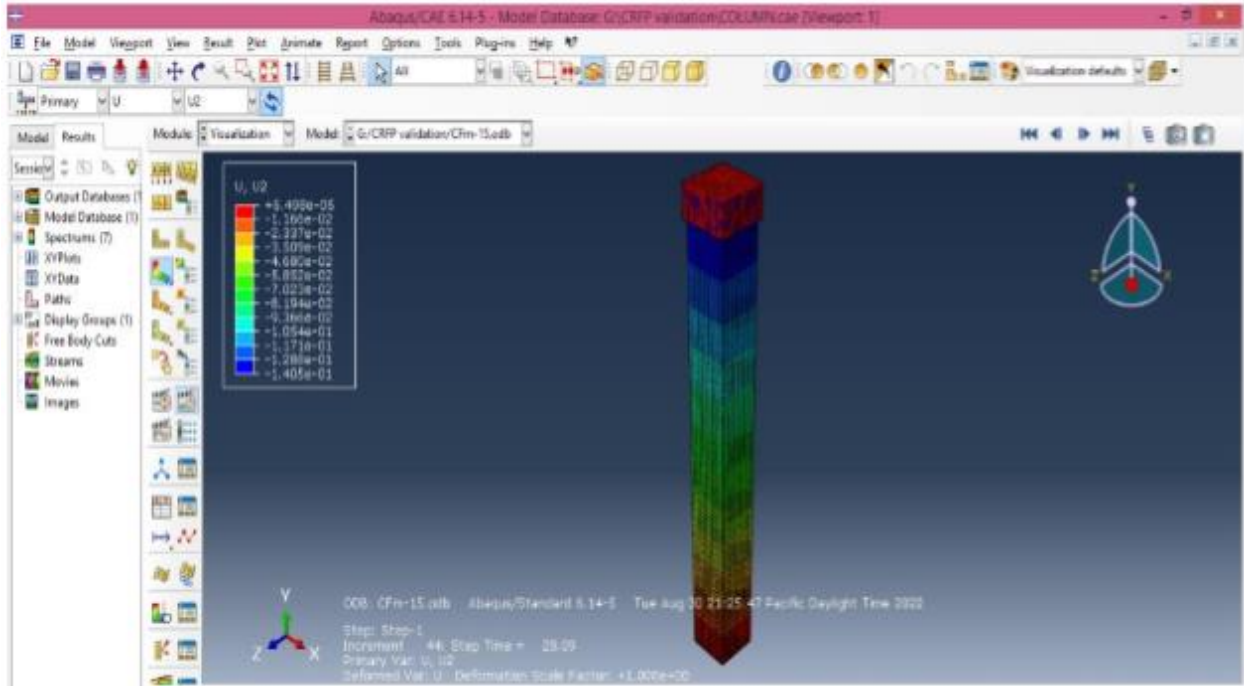

Figure 4.43: Failure mode of CFRP jacketed Reinforced concrete column

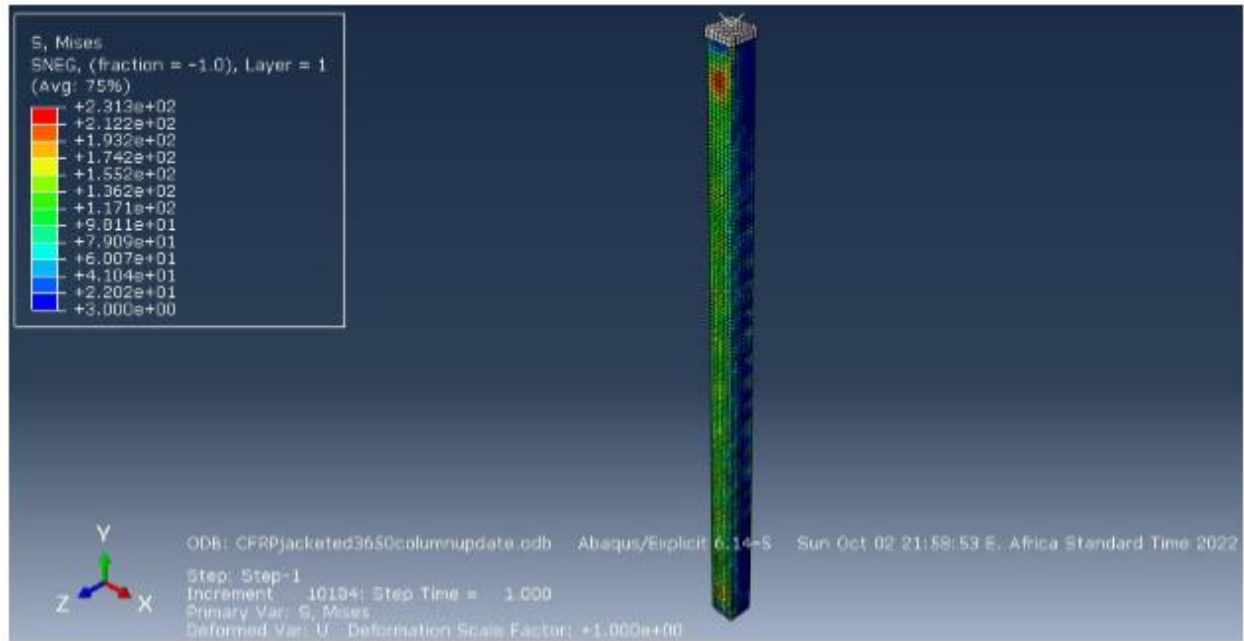

Figure 4.44: Failure mode of CFRP jacketed long reinforced concrete column.

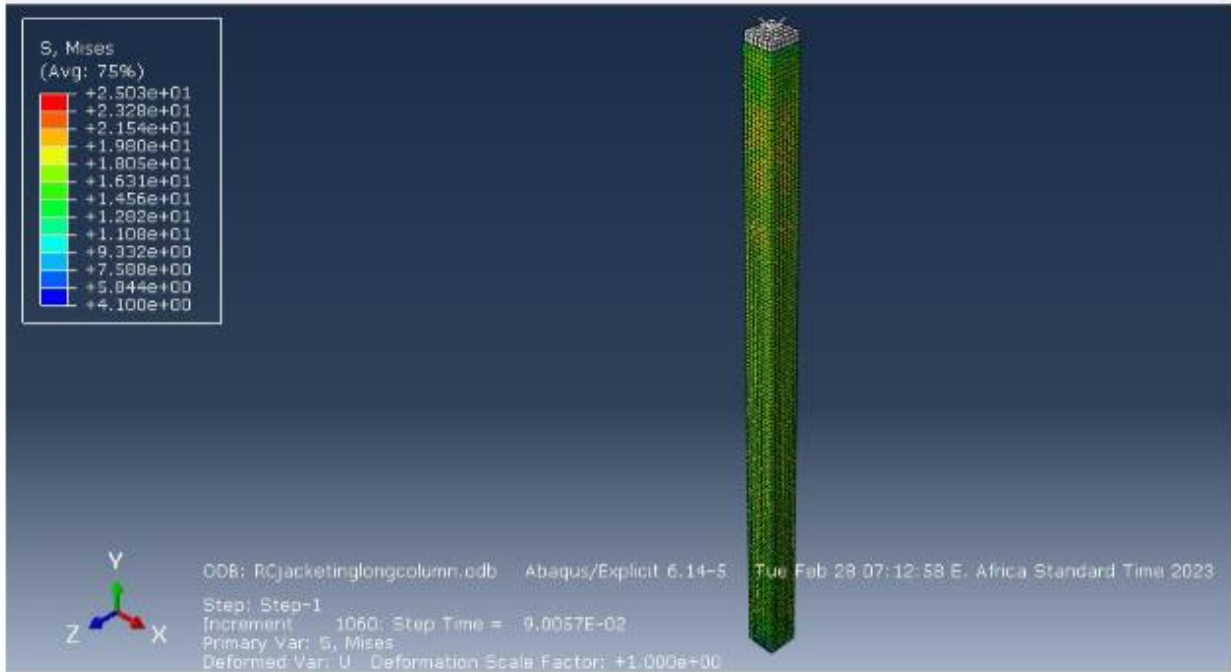

Figure 4.45: Failure mode of RC jacketed long reinforced concrete column.

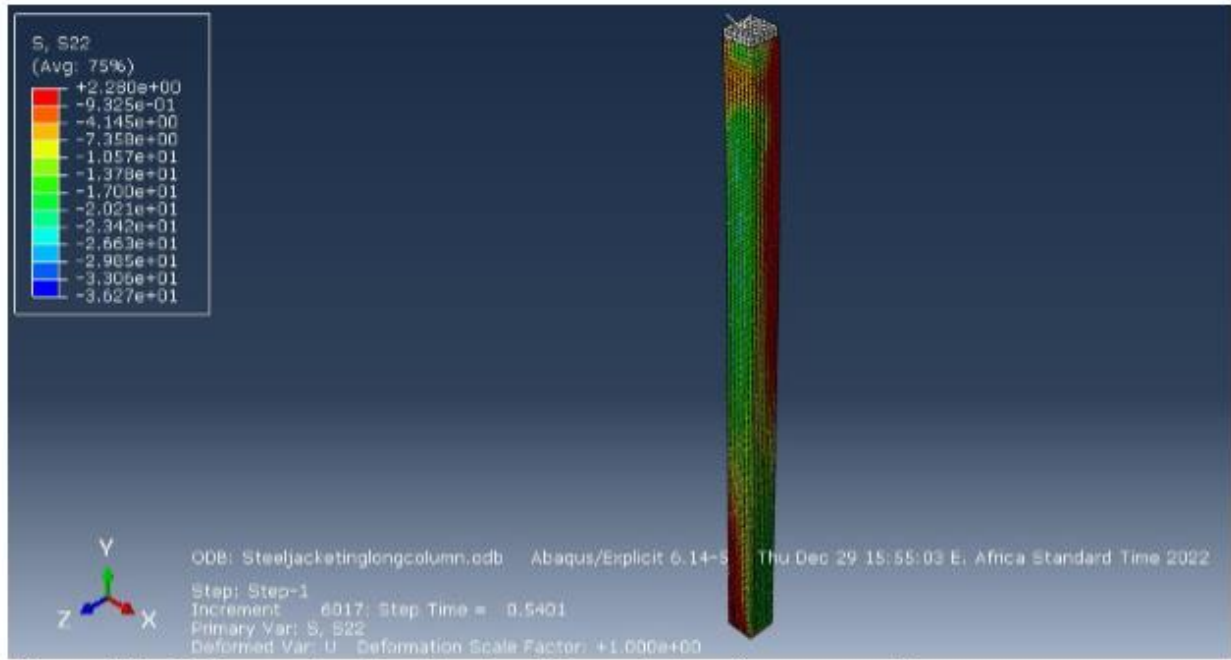

Figure 4.46: Failure mode of steel jacketed long reinforced concrete column.

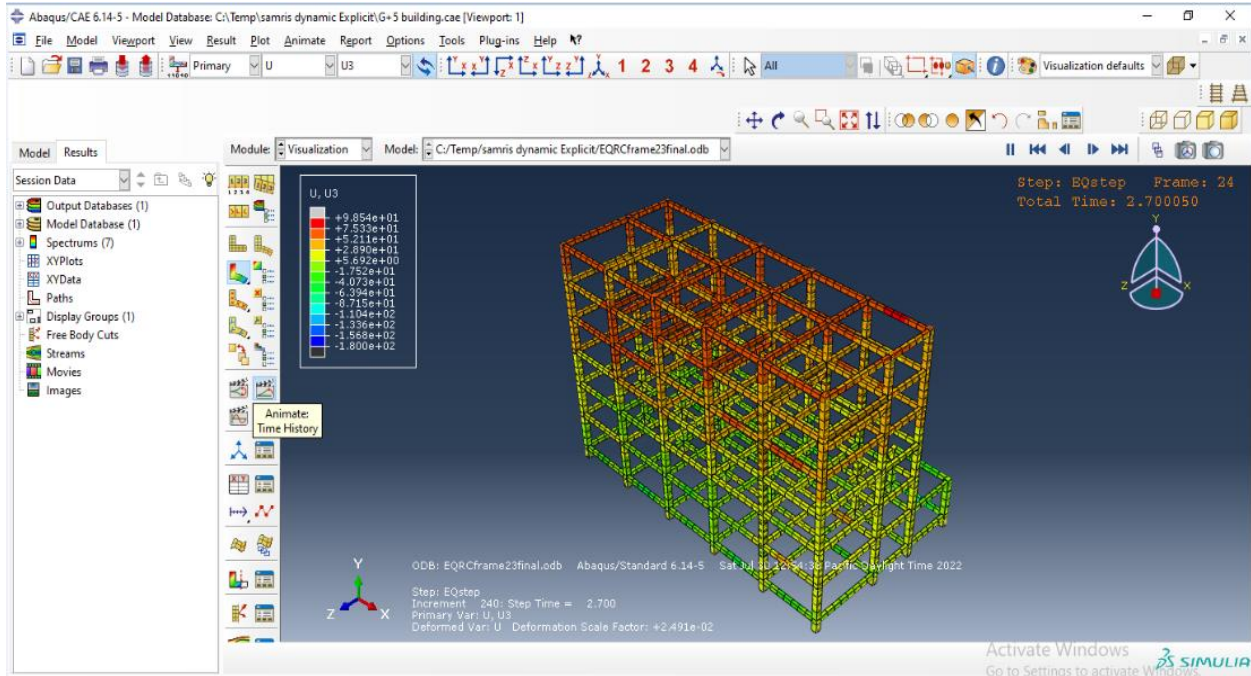

Figure 4.47: Bare reinforced concrete Frame Abaqus output.

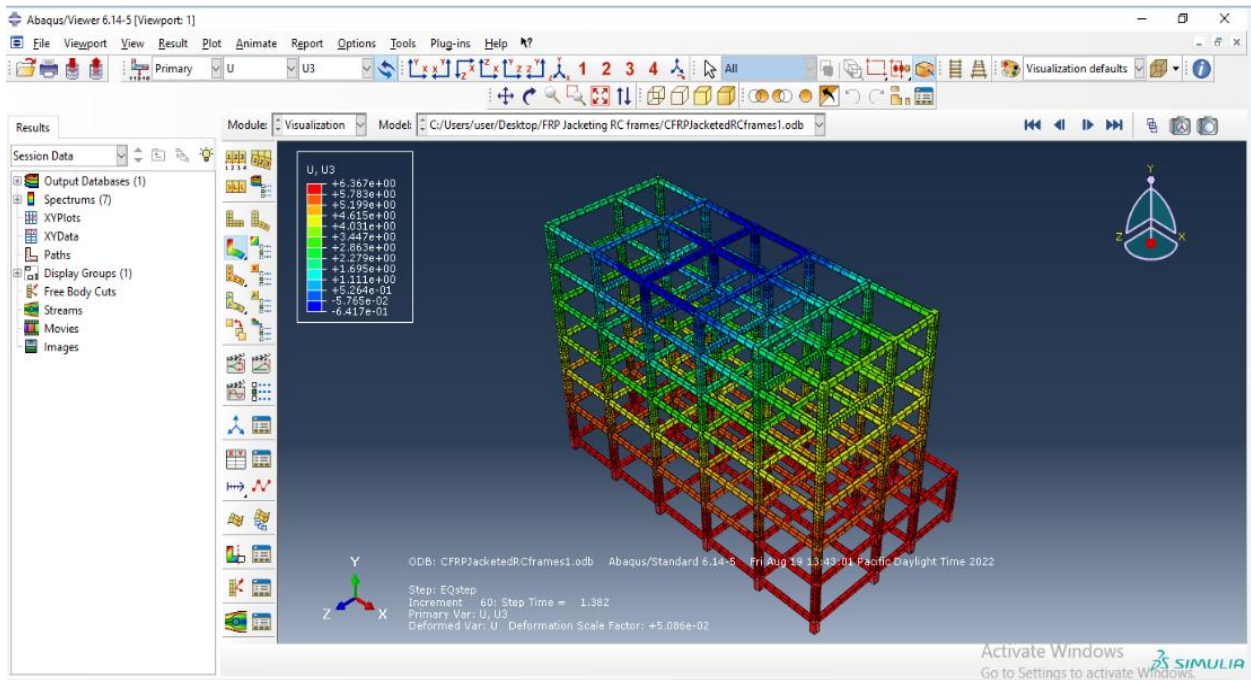

Figure 4.48: Failure mode of carbon Fiber reinforced polymer jacketing Reinforced concrete FrameAbaqusoutput.

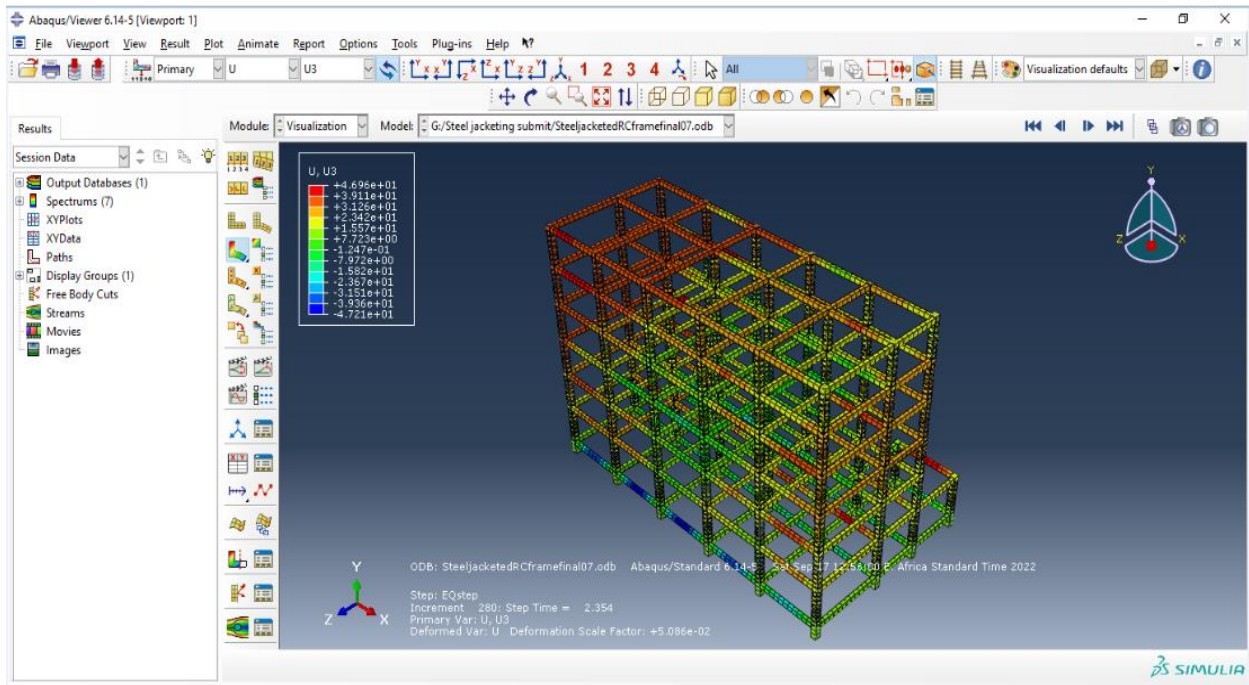

Figure 4.49: Failure mode of steel jacketed Reinforced concrete Frame Abaqus output.

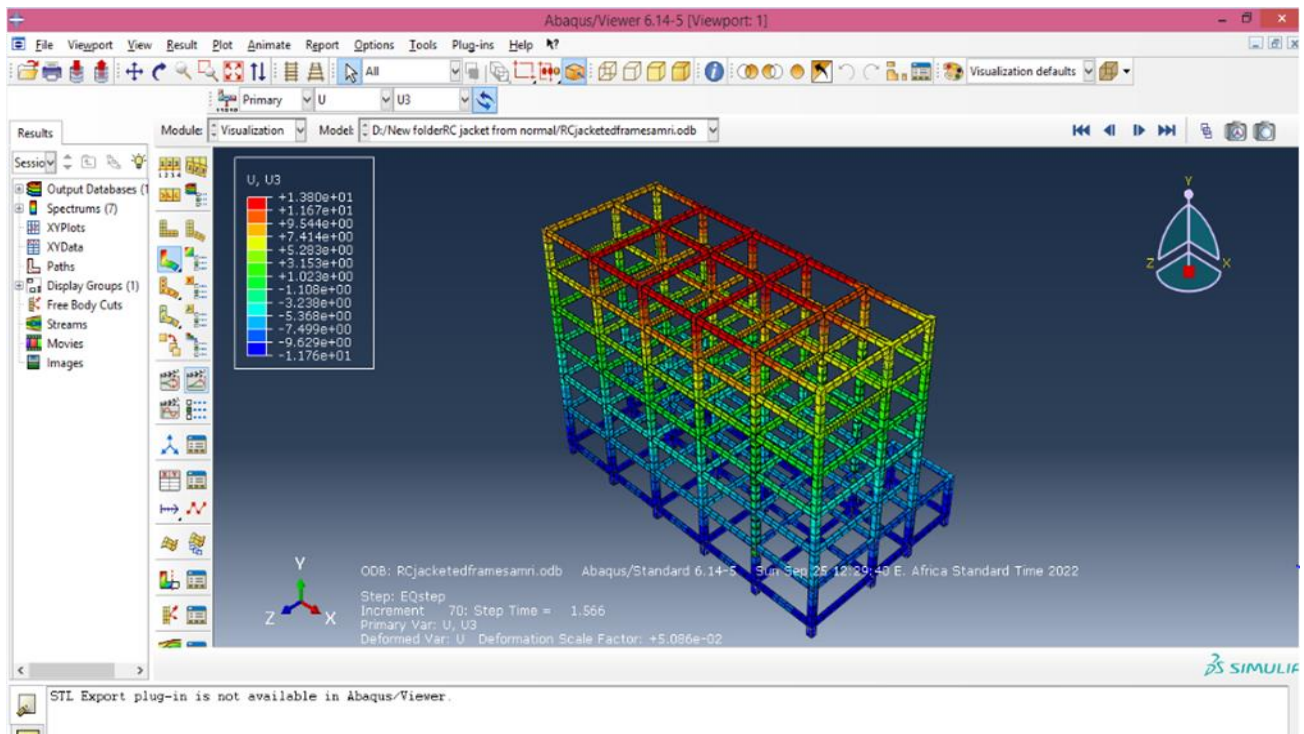

Figure 4.50: Failure mode of RC jacketed Reinforced concrete Frame Abaqus output.

## CHAPTER 5

### CONCLUSION AND RECOMMENDATIONS

A finite element analysis using Abaqus has been conducted to study and compare the efficiency of reinforced concrete, CFRP, and steel jacketing systems on RC frame structures subjected to seismic load and on single columns under axial load. The comparison was in terms of two critical parameters; story displacement and story drift for a retrofitted reinforced concrete frame. For a single column, the study variables of axial load eccentricity and length of the column have been taken to evaluate the load versus displacement results. From the numerical analysis result extracted from the finite element program, the following result as well as some recommendations presented.

#### 5.1 Conclusion

- The performance of the RC jacketing method was found to be very efficient. In this study, the enhancement in ultimate axial capacity of short RC column strengthened by RC jacketing increased by 36.5% and followed by the CFRP jacketing technique with 16.8% axial load carrying capacity enhancement and steel jacketing technique by 2.2%, compared to the bare column. RC Jacketing of columns gives a higher ultimate load result due to the added concrete with longitudinal and transverse reinforcement around the existing columns that increase the cross-sectional area of the concrete.
- For slender columns the axial load-carrying capacity of reinforced concrete columns strengthened with RC jacketing has been improved by 32.1%, CFRP by 31.2%, and steel jacketed by 5.62% compared to the control columns.
- Numerical analysis results from the finite element program indicate that both uni and bi-directional eccentrically loaded column strengthened with RC jacketing technique shows

a greater improvement in ultimate load-carrying capacity followed by steel and CFRP strengthening techniques.

- The reinforced concrete jacketed column gives a greater decrease in story displacement by 40.6% for the top floors and followed by steel jacketing with a decrease in story displacement by 27.37% and CFRP jacketed column decreased by 16.8% relative to the control bare frame.
- The maximum decrease in story drift occurs on the first floor; the reinforced concrete jacketed frames story drift decreased by 51%, steel jacketed by 40.5% and CFRP decreased by 32.68%.
- The failure mode of the RC jacketed column is crushing while jacketing the column with steel changed the failure mode to ductile behavior. The failure in the steel jacketed specimens is due to the buckling of the steel angle followed by the yielding of steel angles and crushing of concrete. The columns strengthened with CFRP sheet failed by rupture occurring in the sheet fibers and followed by concrete failure.
- RC jacketing has been found the most efficient technique for strengthening columns relative to CFRP and steel jacketing techniques.

## 5.2 Recommendations

This research considers regular frames, column dimensions, stiffness, constant concrete grade, steel grade, and loading conditions therefore, further research is required on the following areas.

- The structure considered in this study fulfills plan and elevation regularity, the behaviors for irregular structures under those retrofitting types can be considered for future study.
- The comparative study was carried out under earthquake load, a comparison under wind and blast load can be considered for future researchers.
- The effects of varying column shape and dimension, stiffness, concrete grade, and steel grade on the frame structure jacketed with the three techniques can be study area.

## References

- Abdel-Hay, A.S. (2014) 'Partial strengthening of R.C square columns using CFRP', *HBRC Journal*, 10(3), pp. 279–286. Available at: <https://doi.org/10.1016/j.hbrcj.2014.01.001>.
- Adam, J.M. *et al.* (2009) 'Axially loaded RC columns strengthened by steel caging. Finite element modelling', *Construction and Building Materials*, 23(6), pp. 2265–2276. Available at: <https://doi.org/10.1016/J.CONBUILDMAT.2008.11.014>.
- AL-ALAILY, H.S. (2011) *Retrofit of reinforced concrete columns by composite jacketing*. ARAB ACADEMY FOR SCIENCE AND TECHNOLOGY AND MARITIME TRANSPORT .
- Bagus, I., Widiarsa, R. and Hadi, M.N.S. (2013) 'The 2 nd International Conference on Rehabilitation and Maintenance in Civil Engineering Performance of CFRP Wrapped Square Reinforced Concrete Columns Subjected to Eccentric Loading', *Procedia Engineering*, 54, pp. 365–376. Available at: <https://doi.org/10.1016/j.proeng.2013.03.033>.
- Belal, M.F. *et al.* (2019) 'Behavior of reinforced concrete columns strengthened by steel jacket Behavior of reinforced concrete columns strengthened by steel jacket', 4048. Available at: <https://doi.org/10.1016/j.hbrcj.2014.05.002>.
- Belal, M.F., Mohamed, H.M. and Morad, S.A. (2015) 'Behavior of reinforced concrete columns strengthened by steel jacket', *HBRC Journal*, 11(2), pp. 201–212. Available at: <https://doi.org/10.1016/j.hbrcj.2014.05.002>.
- Campione, G. and Miraglia, N. (2003) 'Strength and strain capacities of concrete compression members reinforced with FRP', *Cement and Concrete Composites*, 25(1), pp. 31–41. Available at: [https://doi.org/10.1016/S0958-9465\(01\)00048-8](https://doi.org/10.1016/S0958-9465(01)00048-8).
- Cheng, Y.M. (1995) *Finite element modelling of reinforced concrete structures with laboratory verification, Structural Engineering and Mechanics*. Available at: <https://doi.org/10.12989/sem.1995.3.6.593>.
- Desayi, P. and Krishnan, S. (1964) 'Equation for the Stress-Strain Curve of Concrete', *Journal Proceedings*, 61(3), pp. 345–350. Available at: <https://doi.org/10.14359/7785>.
- Elkady, A. (2022) (5) #21 ABAQUS Tutorial: Defining Concrete Damage Plasticity Model + Failure and Element Deletion - YouTube. Available at: <https://www.youtube.com/watch?v=wy84XGamn3g&t=1261s> (Accessed: 22 December 2022).



ESA (2015) *Compulsory Ethiopian Standard Design of Structures for Earthquake Resistance - Part 1 : General rules - seismic actions and rules for buildings.*

Ezz-eldeen, H. (2018) ‘Steel Jacketing Technique used in Strengthening Reinforced Concrete Rectangular Columns under Eccentricity for Practical Design Applications’, (May 2016). Available at: <https://doi.org/10.14445/22315381/IJETT-V35P243>.

*FRP Jacketing VS Steel Jacketing - Structural Strengthening Method* (no date). Available at: <https://www.horseen.com/index/solution/content/id/1053> (Accessed: 22 December 2022).

*Introduction to the Finite Element Method for Structural Analysis* (2009). Springer, Dordrecht. Available at: [https://doi.org/10.1007/978-1-4020-8733-2\\_1](https://doi.org/10.1007/978-1-4020-8733-2_1).

Issa, M. *et al.* (2010) ‘Investigation of Reinforced Concrete Columns Strengthened Externally With’, (September 2016).

Jameel, M.T., Sheikh, M.N. and Hadi, M.N.S. (2017) ‘Behaviour of circularized and FRP wrapped hollow concrete specimens under axial compressive load’, *Composite Structures*, 171, pp. 538–548. Available at: <https://doi.org/10.1016/J.COMPSTRUCT.2017.03.056>.

Khalifa, E.S. and Al-Tersawy, S.H. (2014) ‘Experimental and analytical behavior of strengthened reinforced concrete columns with steel angles and strips’, *International Journal of Advanced Structural Engineering*, 6(2). Available at: <https://doi.org/10.1007/s40091-014-0061-6>.

Krishna, P.M. and Kumar, M.A. (2020) ‘An Experimental Study on Behavior of RCC Columns Retrofitted using CFRP’, (August).

Li, Y.F. *et al.* (2005) ‘A constitutive model of concrete confined by steel reinforcements and steel jackets’, *Canadian Journal of Civil Engineering*, 32(1), pp. 279–288. Available at: <https://doi.org/10.1139/L04-093>.

Le Minh, H. *et al.* (2021) ‘A concrete damage plasticity model for predicting the effects of compressive high-strength concrete under static and dynamic loads’, *Journal of Building Engineering*, 44, p. 103239. Available at: <https://doi.org/10.1016/J.JOBE.2021.103239>.

Nasersaeed, H. (2011) ‘Evaluation of behavior and seismic retrofitting of RC structures by concrete jacket’, *Asian Journal of Applied Sciences*, 4(3), pp. 211–228. Available at: <https://doi.org/10.3923/AJAPS.2011.211.228>.

Sadeghian, P., Rahai, A. and Ehsani, M.R. (2010) 'Experimental Study of Rectangular RC Columns Strengthened with CFRP Composites under Eccentric Loading', (April 2017). Available at: [https://doi.org/10.1061/\(ASCE\)CC.1943-5614.0000100](https://doi.org/10.1061/(ASCE)CC.1943-5614.0000100).

*Safeguard your structure by Column Jacketing* (no date). Available at: <https://jacobengineers.in/safeguard-your-structure-by-column-jacketing/> (Accessed: 20 December 2022).

Shrestha, H.D. *et al.* (2009) 'Retrofitting of Existing Vulnerable School Buildings – Assessment to Retrofitting Part II', p. undefined-undefined.

Simulia, D.S. (2014) 'Abaqus 6.14 / Analysis User's Guide', *ABAQUS 6.14 Analysis User's Guide*, I, p. 862.

*Structural Retrofitting - AMERICAN GEOSERVICES* (no date).

Tahghighi, H. and Gholami, M.R. (2018) 'Numerical study of confinement effect of frp coatings on behavior of rc frames by using nonlinear analysis', *Journal of Applied Engineering Science*, 16(3), pp. 430–440. Available at: <https://doi.org/10.5937/jaes16-16866>.

Tarabia, A.M. and Albakry, H.F. (2014) 'Strengthening of RC columns by steel angles and strips', *Alexandria Engineering Journal*, 53(3), pp. 615–626. Available at: <https://doi.org/10.1016/j.aej.2014.04.005>.

Tayeh, B.A. *et al.* (2019) 'Repairing and Strengthening of Damaged RC Columns Using Thin Concrete Jacketing', 2019.

Uy, B. (2002) 'Strength of reinforced concrete columns bonded with external steel plates', *Magazine of Concrete Research*, 54(1), pp. 61–76. Available at: <https://doi.org/10.1680/MACR.54.1.61.40802>.

Vandoros, K.G. and Dritsos, S.E. (2008) 'Concrete jacket construction detail effectiveness when strengthening RC columns', *Construction and Building Materials*, 22(3), pp. 264–276. Available at: <https://doi.org/10.1016/J.CONBUILDMAT.2006.08.019>.

Wu, Y.F., Liu, T. and Oehlers, D.J. (2016) 'Fundamental Principles That Govern Retrofitting of Reinforced Concrete Columns by Steel and FRP Jacketing', <http://dx.doi.org/10.1260/136943306778812769>, 9(4), pp. 507–532. Available at: <https://doi.org/10.1260/136943306778812769>.

## APPENDIX-A

### Material properties

Table A.1: Summary of concrete and steel properties

Material	Density (ton/mm <sup>3</sup> )	Youngs modulus of elasticity (Mpa)	Poisson's ratio
Concrete	2.54e-9	31848	0.2
Steel	7.85e-9	202405	0.3
	7.85e-9	195733	0.3

Table A.2: Concrete damaged plasticity parameters used in the proposed ABAQUS model

Plasticity parameter	Dilation angle	Eccentricity	Stress ratio	Shape factor	Viscosity Parameter
The value used in the model	38	1.12	1	0.6667	0.01

Table A.3 Compressive behavior of concrete damage plasticity for C-25

Yield Stress	Inelastic Strain		Damage Parameter	Inelastic Strain
12.5	0		0	0
14.779363	1.50E-05		0	1.50E-05
16.897181	4.00E-05		0	4.00E-05
18.815096	7.90E-05		0	7.90E-05
20.499689	1.32E-04		0	1.32E-04
21.925443	0.000202		0	0.000202
23.076855	0.00029		0	0.00029
23.949385	0.000396		0	0.000396
24.549184	0.00052		0	0.00052

24.891777	0.000661		0	0.000661
25	0.000816		0	0.000816
24.901601	0.000985		0.003936	0.000985
24.626862	0.001166		0.014926	0.001166
24.206509	0.001356		0.03174	0.001356
23.670071	0.001553		0.053197	0.001553
23.044731	0.001756		0.078211	0.001756
22.354643	0.001964		0.105814	0.001964
21.620626	0.002174		0.135175	0.002174
20.860155	0.002386		0.165594	0.002386
20.087539	0.002598		0.196498	0.002598
19.314226	0.002811		0.227431	0.002811
18.549152	0.003023		0.258034	0.003023
17.799119	0.003235		0.288035	0.003235
17.069142	0.003445		0.317234	0.003445
16.362775	0.003653		0.345489	0.003653
15.682397	0.00386		0.372704	0.00386
15.029454	0.004065		0.398822	0.004065
14.404665	0.004268		0.423813	0.004268
13.80819	0.004469		0.447672	0.004469
13.23977	0.004669		0.470409	0.004669
12.698832	0.004866		0.492047	0.004866
12.184584	0.005062		0.512617	0.005062
11.69608	0.005257		0.532157	0.005257
11.232271	0.005449		0.550709	0.005449
10.792054	0.005641		0.568318	0.005641
10.374298	0.00583		0.585028	0.00583
9.977867	0.006019		0.600885	0.006019
9.601643	0.006206		0.615934	0.006206
9.244531	0.006392		0.630219	0.006392

8.905476	0.006576		0.643781	0.006576
8.583462	0.00676		0.656662	0.00676
8.277519	0.006942		0.668899	0.006942
7.986728	0.007124		0.680531	0.007124
7.710212	0.007304		0.691592	0.007304
7.5	0.007448		0.7	0.007448

Table A.4 Tensile behavior of concrete damage plasticity for C-25

Yield Stress	Cracking Strain		Damage Parameter	Cracking Strain
3	0		0	0
1.664354	0.000281		0.445215	0.000281
1.179148	0.000507		0.606951	0.000507
0.923358	0.000718		0.692214	0.000718
0.76383	0.000923		0.74539	0.000923
0.654173	0.001124		0.781942	0.001124
0.573836	0.001324		0.808721	0.001324
0.512265	0.001522		0.829245	0.001522
0.463463	0.00172		0.845512	0.00172
0.423761	0.001917		0.858746	0.001917

Table A.5 Time vs. acceleration (time-history)  
<https://www.google.com/search?q=accel0.005.xlsx&oq>

Time	Acceleration (mm/s <sup>2</sup> )						
0	-0.00058642	0.2	-0.00386	0.4	-0.00315	0.6	-0.00652
0.005	-0.0001926	0.205	0.007519	0.405	0.002018	0.605	-0.00495
0.01	0.0015497	0.21	-0.00616	0.41	0.004725	0.61	0.000196
0.015	0.00050873	0.215	0.000113	0.415	0.001965	0.615	-0.00254

0.02	0.0011702	0.22	0.004427	0.42	0.006094	0.62	-0.00207
0.025	-0.00060372	0.225	-0.00071	0.425	-0.0005	0.625	0.001274
0.03	0.0030347	0.23	5.39E-05	0.43	0.001131	0.63	0.001142
0.035	-0.00018351	0.235	0.00035	0.435	-0.00401	0.635	-0.00109
0.04	-0.0016621	0.24	0.000252	0.44	0.004306	0.64	0.00555
0.045	-0.0029422	0.245	-0.00297	0.445	0.002539	0.645	-0.00479
0.05	0.0035594	0.25	0.002037	0.45	-0.0032	0.65	0.003872
0.055	0.00068148	0.255	0.006321	0.455	-0.00016	0.655	-0.0024
0.06	-0.0004265	0.26	0.004922	0.46	-0.00108	0.66	-0.00837
0.065	0.0045153	0.265	0.002481	0.465	-0.00671	0.665	-0.00309
0.07	-0.00052157	0.27	-0.00876	0.47	-4.50E-05	0.67	0.002651
0.075	-0.002987	0.275	0.002992	0.475	-0.002	0.675	0.00248
0.08	0.0028889	0.28	0.00042	0.48	-0.00022	0.68	0.00394
0.085	-0.0046055	0.285	0.001729	0.485	-0.00042	0.685	-0.00093
0.09	-0.0084664	0.29	0.001697	0.49	0.000962	0.69	-0.00127
0.095	0.0078378	0.295	-0.00297	0.495	0.003149	0.695	0.002803
0.1	0.0043367	0.3	0.003425	0.5	-0.00084	0.7	-0.01109
0.105	-0.00035865	0.305	-0.00114	0.505	0.001073	0.705	0.000597
0.11	-0.0015216	0.31	0.002857	0.51	0.001952	0.71	-0.00142
0.115	-0.0032504	0.315	-0.00653	0.515	-0.00783	0.715	-0.00231
0.12	-0.0086723	0.32	0.000644	0.52	0.005668	0.72	0.004114
0.125	-0.0048807	0.325	-0.00601	0.525	-0.00431	0.725	0.004029
0.13	0.0018469	0.33	0.000396	0.53	0.003579	0.73	0.004611
0.135	0.0042954	0.335	0.001899	0.535	0.003664	0.735	-0.00852
0.14	0.0014322	0.34	0.001927	0.54	0.0011	0.74	8.28E-05
0.145	0.0040518	0.345	0.000736	0.545	-0.00071	0.745	-0.00328
0.15	-0.0014169	0.35	-0.00285	0.55	-0.00233	0.75	-0.0006
0.155	8.92E-05	0.355	0.002735	0.555	-0.00029	0.755	-0.0023
0.16	-0.00048918	0.36	0.000246	0.56	-0.00099	0.76	0.004861
0.165	0.00087565	0.365	0.000284	0.565	0.005743	0.765	-0.00713
0.17	0.0069997	0.37	0.00608	0.57	-0.00842	0.77	0.003791
0.175	0.0047491	0.375	0.003085	0.575	0.002443	0.775	-0.00551
0.18	0.0078769	0.38	0.000248	0.58	0.000611	0.78	-0.00031
0.185	0.0014488	0.385	0.005873	0.585	-0.00248	0.785	-0.00021
0.19	0.0052096	0.39	-0.00172	0.59	-0.00702	0.79	-0.00071
0.195	-0.0078563	0.395	-0.00061	0.595	0.003435	0.795	0.006701

1	-0.021452
1.005	-0.0030461
1.01	-0.0007462
1.015	0.0034019

0.8	0.001327
0.805	-0.00295
0.81	-0.00149
0.815	0.000415

1.4	-0.01809
1.405	-0.02174
1.41	-0.04006
1.415	-0.02189

1.2	-0.01189
1.205	0.002891
1.21	-0.00479
1.215	0.003868

1.02	0.015462	0.82	-0.00222	1.42	-0.01882	1.22	0.002728
1.025	-0.020349	0.825	-0.0008	1.425	-0.00712	1.225	0.000824
1.03	0.026679	0.83	-0.00577	1.43	-0.01046	1.23	0.007435
1.035	-0.026249	0.835	0.008213	1.435	-0.01299	1.235	-0.00943
1.04	0.0082934	0.84	0.002085	1.44	0.005394	1.24	0.006411
1.045	-0.0081082	0.845	-0.00946	1.445	-0.00012	1.245	0.00223
1.05	-0.0001726	0.85	-0.00044	1.45	-0.01052	1.25	-0.00619
1.055	0.0066366	0.855	-0.01085	1.455	-0.02975	1.255	0.010252
1.06	-0.0011336	0.86	-0.00307	1.46	-0.04708	1.26	0.005605
1.065	0.013324	0.865	0.0111	1.465	-0.0429	1.265	0.008165
1.07	-0.014378	0.87	0.002478	1.47	-0.01299	1.27	-0.00379
1.075	0.011963	0.875	0.005338	1.475	-0.00252	1.275	-0.00805
1.08	-0.011801	0.88	-0.00095	1.48	0.037413	1.28	0.013514
1.085	0.0064862	0.885	-0.00835	1.485	0.051147	1.285	-0.01316
1.09	-0.005083	0.89	-0.01293	1.49	0.097297	1.29	-0.0011
1.095	0.0036288	0.895	-0.01256	1.495	0.081157	1.295	0.008846
1.1	0.0007198	0.9	0.007769	1.5	0.003006	1.3	-0.01576
1.105	0.0063406	0.905	0.011607	1.505	-0.05118	1.305	0.016781
1.11	-0.012546	0.91	0.007996	1.51	-0.12842	1.31	-0.00901
1.115	-0.0050683	0.915	-0.00211	1.515	-0.09446	1.315	-0.0066
1.12	0.0055655	0.92	-0.01039	1.52	-0.06007	1.32	-0.00413
1.125	-0.017858	0.925	-0.01502	1.525	0.09707	1.325	-0.00883
1.13	0.016955	0.93	-0.00662	1.53	0.18942	1.33	-0.00279
1.135	-0.0081347	0.935	0.009633	1.535	0.18859	1.335	-0.00413
1.14	0.012131	0.94	-0.00597	1.54	0.06338	1.34	0.009579
1.145	-0.0001296	0.945	0.013241	1.545	-0.17734	1.345	0.011057
1.15	0.0059931	0.95	0.013288	1.55	-0.33758	1.35	0.011427
1.155	0.0037933	0.955	-0.00497	1.555	-0.30528	1.355	0.010248
1.16	0.001384	0.96	-0.007	1.56	-0.02622	1.36	-0.00939
1.165	-0.0057997	0.965	0.008815	1.565	0.15556	1.365	-0.00647
1.17	0.010618	0.97	-0.00632	1.57	0.3063	1.37	-0.02418
1.175	0.0001951	0.975	0.00205	1.575	0.34465	1.375	-0.02702
1.18	-0.000379	0.98	-0.00227	1.58	0.051933	1.38	-0.01874
1.185	-0.003387	0.985	0.014005	1.585	0.093786	1.385	0.006827
1.19	-0.0037736	0.99	-0.01549	1.59	-0.1836	1.39	0.009505
1.195	0.0062107	0.995	0.018949	1.595	-0.21969	1.395	0.013792

1.6	-0.12375	1.8	0.30849
1.605	0.1467	1.805	-0.4897
1.61	0.28739	1.81	-0.76007
1.615	0.35335	1.815	-0.80747

2	-0.16404
2.005	0.093863
2.01	-0.01943
2.015	-0.82644

2.2	0.34525
2.205	1.0396
2.21	0.34266
2.215	0.24921

1.62	0.20179	1.82	-0.3425	2.02	-0.6933	2.22	-0.08999
1.625	0.14716	1.825	-0.06015	2.025	-0.59133	2.225	-0.62182
1.63	-0.14012	1.83	0.90416	2.03	0.59363	2.23	-0.61806
1.635	-0.18637	1.835	1.1735	2.035	0.65824	2.235	-0.32444
1.64	-0.26117	1.84	0.82991	2.04	0.92672	2.24	-0.18262
1.645	-0.15043	1.845	-0.45769	2.045	0.80232	2.245	0.046797
1.65	-0.03262	1.85	-0.37106	2.05	0.74243	2.25	0.64952
1.655	0.1534	1.855	-0.86459	2.055	-0.23269	2.255	0.86035
1.66	0.19135	1.86	-1.1043	2.06	-1.1047	2.26	0.52686
1.665	0.17472	1.865	-0.15999	2.065	-1.3659	2.265	0.019809
1.67	-0.23853	1.87	0.24253	2.07	-0.95694	2.27	-0.00547
1.675	-0.49894	1.875	0.18789	2.075	-0.37481	2.275	-0.18629
1.68	-0.41107	1.88	1.0485	2.08	1.4082	2.28	0.01788
1.685	-0.04649	1.885	0.51679	2.085	1.5254	2.285	0.33116
1.69	0.23218	1.89	0.001995	2.09	1.8226	2.29	-0.57325
1.695	0.52692	1.895	-0.08664	2.095	0.74492	2.295	-1.1765
1.7	0.54571	1.9	-0.87428	2.1	-1.211	2.3	0.018566
1.705	0.50615	1.905	-0.83276	2.105	-1.8576	2.305	0.63352
1.71	-0.16515	1.91	-0.25266	2.11	-1.3322	2.31	1.2725
1.715	-0.70246	1.915	0.34346	2.115	-0.31601	2.315	0.33513
1.72	-0.63244	1.92	0.67633	2.12	0.83323	2.32	-0.87866
1.725	-0.41874	1.925	0.82812	2.125	1.3994	2.325	-2.0392
1.73	-0.47251	1.93	0.24674	2.13	1.1116	2.33	-1.5874
1.735	0.1489	1.935	-0.16556	2.135	0.38102	2.335	-0.06536
1.74	0.81961	1.94	-0.11238	2.14	0.11628	2.34	1.2187
1.745	0.71654	1.945	0.20715	2.145	-1.6983	2.345	1.2576
1.75	0.55461	1.95	0.065992	2.15	-1.7054	2.35	0.85658
1.755	0.1056	1.955	-0.07142	2.155	-0.65631	2.355	0.51881
1.76	-0.42343	1.96	-0.39554	2.16	0.2367	2.36	-0.49614
1.765	-1.3818	1.965	-0.58781	2.165	1.4475	2.365	-0.41141
1.77	-0.89231	1.97	-0.10576	2.17	2.5803	2.37	-0.76992
1.775	-0.12709	1.975	0.50911	2.175	0.94194	2.375	-0.91569
1.78	0.45977	1.98	0.29837	2.18	-1.1471	2.38	0.27388
1.785	0.7725	1.985	-0.16069	2.185	-1.7653	2.385	0.78958
1.79	1.044	1.99	-0.09726	2.19	-1.1335	2.39	0.70573
1.795	0.35477	1.995	-0.11582	2.195	-0.56801	2.395	1.3264
2.4	-0.16048	2.6	-0.15087	2.8	0.13218	3	-1.4472
2.405	-0.59712	2.605	0.25928	2.805	-1.7242	3.005	-0.48084
2.41	-0.89225	2.61	0.5406	2.81	-1.9936	3.01	-0.77372
2.415	-0.7453	2.615	-0.39961	2.815	-0.27624	3.015	-0.41479
2.42	-0.01147	2.62	0.45606	2.82	-0.37567	3.02	0.63917



2.425	0.78833	2.625	0.34178	2.825	0.10989	3.025	1.0141
2.43	0.086504	2.63	-0.21716	2.83	1.7252	3.03	-0.32958
2.435	0.208	2.635	-0.20617	2.835	1.0838	3.035	-0.13456
2.44	-0.12803	2.64	0.36373	2.84	-0.04616	3.04	0.58311
2.445	0.20736	2.645	-0.01937	2.845	-0.6475	3.045	-0.43794
2.45	0.1146	2.65	0.072266	2.85	-0.69044	3.05	-0.54441
2.455	0.46865	2.655	-0.04984	2.855	-1.2489	3.055	0.44596
2.46	0.19345	2.66	0.098579	2.86	-0.61796	3.06	0.69572
2.465	-0.76334	2.665	-0.05206	2.865	0.69001	3.065	-0.12552
2.47	-0.5596	2.67	-0.13925	2.87	1.2045	3.07	0.56473
2.475	0.22588	2.675	0.58358	2.875	0.44208	3.075	-0.46098
2.48	0.87686	2.68	0.0512	2.88	0.81992	3.08	-0.71326
2.485	1.2463	2.685	-0.69584	2.885	-0.07771	3.085	-0.97587
2.49	0.51593	2.69	-0.21603	2.89	-1.3602	3.09	-0.53973
2.495	-0.12521	2.695	0.74049	2.895	-1.2837	3.095	0.54726
2.5	-0.58335	2.7	-0.13877	2.9	-0.10733	3.1	0.9824
2.505	-1.7804	2.705	0.63617	2.905	0.23189	3.105	1.1504
2.51	-1.3812	2.71	0.73516	2.91	0.53051	3.11	0.48288
2.515	-0.5817	2.715	-0.62475	2.915	0.53704	3.115	-0.60107
2.52	0.48821	2.72	-0.46063	2.92	0.70265	3.12	-0.59927
2.525	1.246	2.725	-0.78818	2.925	0.11495	3.125	-1.4916
2.53	1.9931	2.73	-1.112	2.93	0.078012	3.13	-1.1024
2.535	1.3042	2.735	0.23726	2.935	-0.02814	3.135	0.20701
2.54	-1.3297	2.74	0.69019	2.94	-0.19428	3.14	0.64622
2.545	-2.3384	2.745	0.60288	2.945	-0.14477	3.145	0.80951
2.55	-1.6094	2.75	1.1615	2.95	0.31649	3.15	1.5416
2.555	-0.9119	2.755	0.78596	2.955	0.37666	3.155	-0.38483
2.56	0.35684	2.76	-0.43327	2.96	-0.66248	3.16	-1.0017
2.565	2.7869	2.765	-0.73717	2.965	-1.2932	3.165	-0.1039
2.57	2.0378	2.77	-1.832	2.97	-0.06882	3.17	-0.40165
2.575	0.1261	2.775	-0.60927	2.975	0.12641	3.175	-0.34421
2.58	-0.64087	2.78	0.10309	2.98	0.93818	3.18	1.0014
2.585	-1.2484	2.785	1.7027	2.985	1.7867	3.185	1.4228
2.59	-1.0596	2.79	1.6241	2.99	1.3225	3.19	0.17637
2.595	-0.54444	2.795	0.82398	2.995	-1.0146	3.195	-0.6719

3.2	-0.7365	3.4	0.85763
3.205	-0.73832	3.405	-0.98574
3.21	-0.68846	3.41	-1.5245
3.215	-0.30153	3.415	-1.4107
3.22	1.2169	3.42	-1.5762

3.225	0.88687	3.425	1.0836
3.23	0.66428	3.43	2.4074
3.235	0.69907	3.435	1.4221
3.24	-0.02876	3.44	0.8116
3.245	-1.6979	3.445	0.51095
3.25	-1.2923	3.45	-0.99533
3.255	-0.40934	3.455	-1.2875
3.26	1.1844	3.46	-0.95385
3.265	0.62051	3.465	-0.92016
3.27	1.2088	3.47	-0.20192
3.275	1.0103	3.475	1.5005
3.28	-0.31022	3.48	1.7211
3.285	-0.5509	3.485	0.5399
3.29	0.34358	3.49	0.50525
3.295	-1.0384	3.495	-1.1422
3.3	-1.023	3.5	-2.8068
3.305	-0.69435	3.505	-1.4673
3.31	-0.29312	3.51	0.6974
3.315	0.32761	3.515	1.7739
3.32	1.2935	3.52	1.4823
3.325	1.0115	3.525	1.378
3.33	-0.02509	3.53	-0.42712
3.335	-0.78209	3.535	-1.1379
3.34	-1.1401	3.54	-0.64481
3.345	-0.19992	3.545	-0.2982
3.35	0.40965	3.55	-0.35775
3.355	0.3671	3.555	0.66074
3.36	0.33587	3.56	-0.66925
3.365	0.60952	3.565	0.40753
3.37	-1.1995	3.57	0.38208
3.375	-0.90494	3.575	0.29146
3.38	-0.0565	3.58	0.21076
3.385	-0.16811	3.585	0.20582
3.39	0.41768	3.59	-0.79502
3.395	2.0726	3.595	-0.19929

## APPENDIX-B

The output of eccentricity and length of the column.

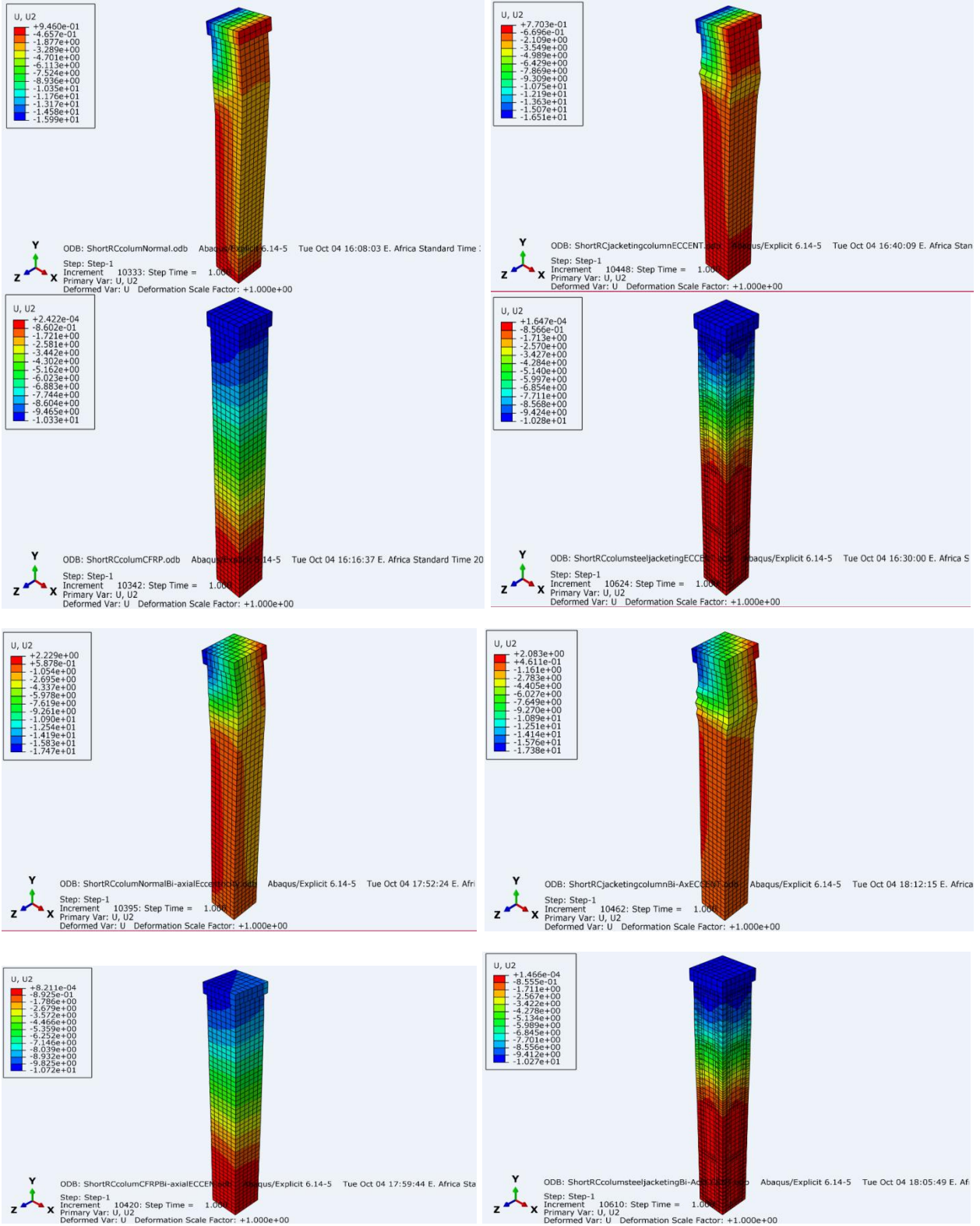

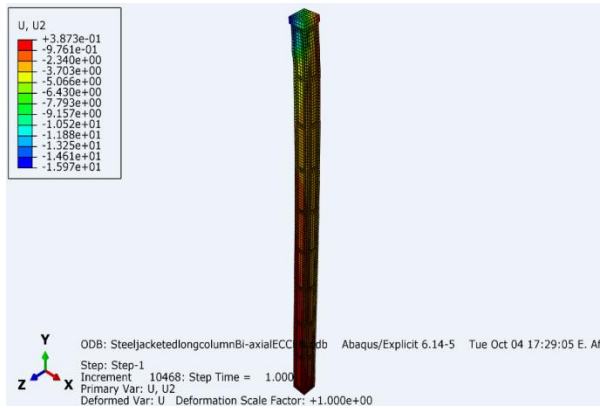
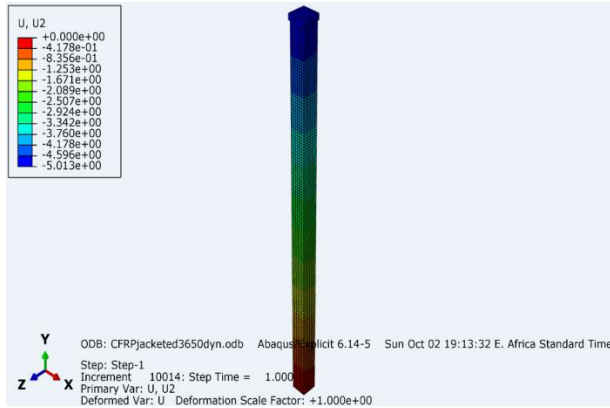
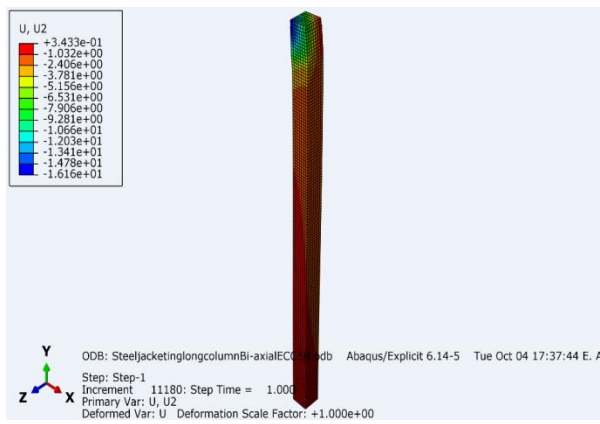
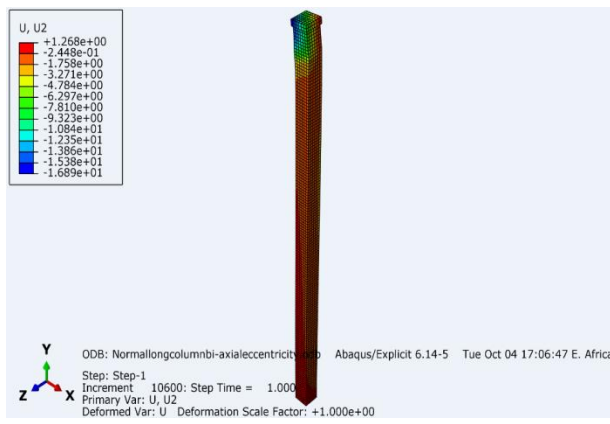
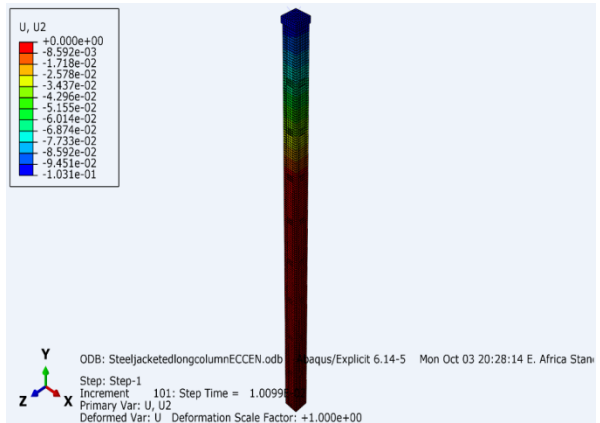
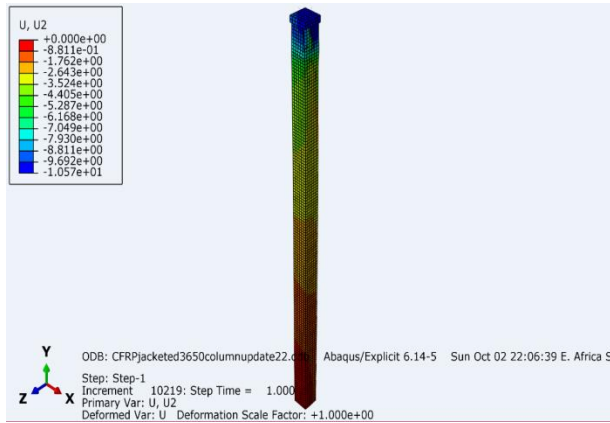
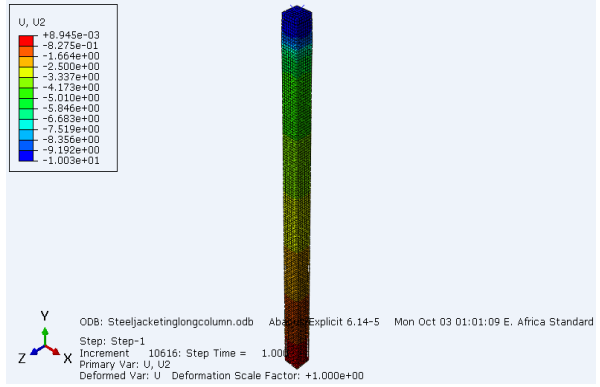
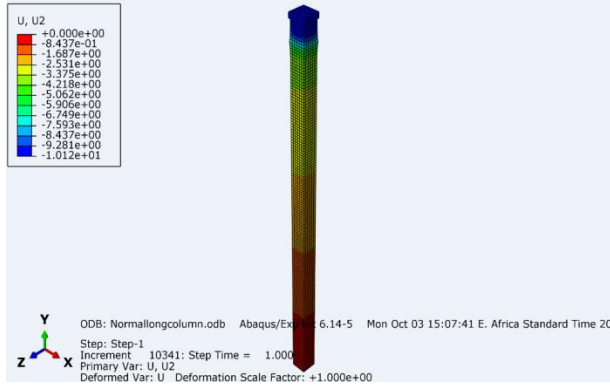

## APPENDIX-C

Displacement versus force for Long and Short column.

Table C.1: Displacement versus force for Bare, CFRP, RC and steel jacketed column.

Bare RC long column		CFRP Jacketed long RC column		Steel jacketed long RC column	
Displacement	Force	Displacement	Force	Displacement	Force
0	0	0	0	0	9.89E-07
0.050995	57564.55	0.050995	59084.71	0.050995	68527.73
0.10099	56257.82	0.10099	57643.88	0.10099	65733.07
0.150985	57657.98	0.150985	58945.42	0.150984	67057.75
0.20098	57412.9	0.20098	58621.53	0.200979	66423.86
0.250972	56238.41	0.250973	57793.66	0.250972	66415.31
0.300963	57651.26	0.300963	58958.38	0.300961	67612.44
0.350953	57503.3	0.350953	58756.17	0.350951	67673.15
0.400943	56728.16	0.400943	58068.38	0.400941	67183.05
0.450934	120544.4	0.450933	111030	0.450931	125722.1
0.50092	181896.1	0.50092	191495.9	0.500917	202440.3
0.550906	168825.2	0.550905	172983.9	0.550903	191865.7
0.600892	168327.5	0.600891	170639.4	0.600889	203101.6
0.650877	168911.5	0.650877	168207.5	0.650875	205207.3
0.700861	169183.3	0.700861	170117.2	0.700859	201500.1
0.750842	172716.3	0.750841	175267.4	0.750792	201349.7
0.800823	173897	0.800822	176672.7	0.800444	200925.7
0.850804	172226.3	0.850803	176144.7	0.850416	198900.6
0.900786	243226.7	0.900785	229472.9	0.900394	253639.1
0.950219	272862.7	0.950761	289390.9	0.950371	314823.7
1.000036	279476.8	1.000737	288250.2	1.000238	321351.8
1.05083	277364.6	1.050712	282272.5	1.050204	321076.9
1.100647	279995.3	1.100688	281589.1	1.100081	321301.7
1.150464	280415.4	1.150663	287361.6	1.150974	321915.1
1.20028	279858.9	1.200637	286574.8	1.200869	323155.7
1.250097	281238.2	1.250609	284081	1.250764	323241.9
1.300891	280535.3	1.30058	285779.8	1.300654	323392.8
1.350708	293098.4	1.350551	296495.4	1.350605	331781.6
1.400815	322310.4	1.400521	320705.6	1.400574	362695
1.450785	353083.8	1.45049	355446.4	1.45047	408439.6
1.500752	370570.2	1.500457	375393.5	1.500379	429116.3
1.550719	370997.3	1.550423	377792.8	1.550346	428423.9
1.600685	370873.1	1.60039	377966.6	1.600177	428878.7
1.650652	371403.3	1.650357	378398.8	1.650994	429581.2
1.700618	371948	1.700323	379695.3	1.700815	430227.1

1.750581	372349.5
1.800541	372979.9
RC Jacketed long RC column	
Displacement	Force
0	0
0.050173	116790.5
0.100158	113533.4
0.150142	116853.2
0.200131	114018.4
0.25012	114108.3
0.300109	115214.4
0.35009	117303.8
0.400308	117397.8
0.450268	118362.8
0.50023	114868
0.550191	116012.2
0.60015	115336.5
0.65011	185083
0.700837	386529
0.750678	332341.6
0.800332	326373.1
0.850139	334624.5
0.900797	338077.7
0.95059	343488.5
1.000397	346957.3
1.050256	345926.4
1.100782	345924.5
1.150534	350590.1
1.200329	347054.1
1.25012	346106.3
1.300876	375924.2
1.350814	414457.3
1.400379	480603.7
1.450157	516830.8
1.500281	527319.9
1.55068	529492.9
1.600139	529464.9
1.650786	530741
1.700439	531762.4
1.750063	532475.3

1.750286	380454.8
1.800237	381609.4
Bare Short column	
Displacement	Force
0	0
0.050995	53432.9
0.100988	54812.84
0.150978	116261.7
0.200963	157880.6
0.250947	162488.9
0.300927	237557.4
0.350903	270367.3
0.400225	271261.2
0.450375	320714.2
0.500525	370383.1
0.550385	373092.7
0.600037	386852.5
0.650376	447977.2
0.700492	457342.2
0.750107	459533.2
0.800376	473533.9
0.850042	508956.3
0.900675	526403
0.950813	528769.6
1.000807	533483.6
1.050716	543169.4
1.10006	558681.9
1.150521	573204.5
1.200369	579560.3
1.250283	582163.1
1.300097	584722.9
1.350611	588539.3
1.400107	590543.8
1.450108	594046.1
1.50031	599643.3
1.550601	602774.6
1.600529	605485.6
1.650625	608515.9
1.70012	610816.5
1.750686	612243.3

1.750635	430498.8
1.80032	431602.9
CFRP jacketed short column	
Displacement	Force
0	0
0.050995	58715.29
0.100988	58670.9
0.150978	117771.1
0.200964	168735.5
0.250947	172075.3
0.300927	236645.1
0.350498	301925
0.400205	298386.7
0.4504	333839.6
0.500593	397605
0.550024	400248.5
0.600201	411157.4
0.650848	480172.8
0.700967	489677.1
0.750913	493696.8
0.800407	510555.3
0.850668	551441.8
0.900296	570065.9
0.950153	573344.8
1.000464	582019.8
1.050735	599035.2
1.1001	620227.1
1.150689	635318.9
1.200465	640518.6
1.250002	643982.5
1.300895	650755.3
1.350086	659901.9
1.400099	672950.3
1.450276	683816.5
1.500485	691936.1
1.550471	695658.2
1.600342	698152.3
1.650361	703843.4
1.700492	709899.2
1.750353	714611.6

1.800668	534203.8	1.800685	611366.6	1.800764	718953.2
----------	----------	----------	----------	----------	----------

Steel jacketed short column	
Displacement	Force
0	0
0.050995	56110.57
0.100988	56131.06
0.150977	112637.2
0.200963	158525.7
0.250946	163045.4
0.300926	225498.6
0.35089	282982.3
0.400168	279051.7
0.450932	316866.4
0.500748	373741.9
0.550568	378895.5
0.600668	390104.5
0.650579	452641.1
0.700976	463988.3
0.750586	467385.8
0.800421	479132.2
0.850931	514721.3
0.900565	535870.8
0.950889	537380.3
1.00008	542669.2
1.050442	552859.7
1.100509	567571.1
1.150313	582643.5
1.200227	590189.6
1.250624	594463.1
1.30083	597505.3
1.350873	600885.8
1.400704	604336.9
1.450467	607795.8
1.500222	610902.9
1.550301	615022.5
1.600088	620756.6
1.65026	623732.8
1.700427	624593.1
1.750485	625539.3
1.800358	625801.3

RC jacketed short column	
Displacement	Force
0	0
0.050996	65597.19
0.100989	63511.64
0.150979	196056.1
0.200965	184938.1
0.250948	190975.2
0.300929	346417.2
0.350891	317210.5
0.400166	320613.1
0.450086	448351.3
0.500395	441657.2
0.550788	451068.6
0.600811	538952.1
0.650323	555293.6
0.700375	561050.1
0.750507	602875.1
0.800488	648134.2
0.850142	657130.9
0.900757	670399.9
0.95031	700651.6
1.000112	733908.4
1.050767	744879.3
1.100745	754978.3
1.150664	772035.8
1.200939	792694
1.250451	817051.4
1.300083	825817
1.350087	836607.6
1.400683	846508.3
1.4504	864572.1
1.500185	877155.6
1.550209	890827.1
1.600215	900761.8
1.650074	907686.1
1.700805	919024.2
1.750546	928233.3
1.800033	940112.3

Table C.2: Displacement versus force Uni and Bi-directional eccentricity for Bare, CFRP, RC, and steel jacketed column.

CFRP Jacketed long RC column eccentricity 20mm		RC Jacketed long RC column eccentricity 20mm		Steel jacketed long RC column eccentricity 20mm	
Displacement	Force	Displacement	Force	Displacement	Force
0	0	0	0	0	-24.3804
0.050994	58815.4	0.050843	114471.8	0.050994	65247.78
0.100986	57430.96	0.100795	112782.8	0.100985	65629.55
0.150979	58366.91	0.150742	115168.5	0.150973	65337.52
0.200971	58167.14	0.200724	113653.8	0.200959	67410.58
0.250963	57374.33	0.250701	113651.5	0.250945	65400.44
0.300953	58474.89	0.300669	114682.4	0.30093	66045.34
0.350943	58438.19	0.350644	116334.4	0.350914	66069.95
0.400933	57726.74	0.400133	116208	0.400899	64133.26
0.450922	105476.5	0.450916	117260.6	0.450883	112362.5
0.500902	185423.2	0.500704	114115.3	0.500705	178772.4
0.55088	170020.6	0.550491	115419.6	0.55027	178649.6
0.600836	168816.5	0.600276	115058.7	0.600847	192776.5
0.650807	166982.3	0.650061	178614.5	0.650381	203433.9
0.700783	169175.7	0.700144	371105	0.700017	200745.1
0.75076	173438.2	0.750479	322425	0.750649	186286.7
0.800737	175559.6	0.800688	322910.2	0.800007	190341.4
0.850712	174351.6	0.850871	330300.8	0.850418	193635.3
0.900687	214645.6	0.900177	335747	0.900651	232493.5
0.950393	278755.5	0.950395	340737.6	0.950699	272643.8
1.000215	282212.4	1.000613	342359.9	1.000766	292420.2
1.050036	276079.6	1.05083	341974.2	1.050605	292305.7
1.100797	277101.6	1.100148	342396.9	1.100545	309167
1.150619	282409.1	1.150363	343846.5	1.150463	322076.3
1.20044	282014.3	1.200578	342215.1	1.200302	304690
1.250261	279616.6	1.250793	341971.6	1.250141	302294.9
1.300079	281507.9	1.300111	364050.8	1.300938	304834.7
1.350126	288069.4	1.350637	408176	1.350777	314539.5
1.400559	313652.2	1.400638	464415.3	1.400616	350445.2
1.450383	349478.7	1.450238	497529.9	1.450588	379232.5
1.500474	360411.7	1.500009	505230.5	1.500251	382866.4
1.550306	362609.3	1.550753	509201.8	1.550122	387820.7
1.600905	363366.9	1.600861	509922.9	1.600437	396782.7
1.650022	365562.4	1.650172	513836.9	1.650273	407689
1.7006	369579.2	1.70077	515720.9	1.700105	397855.9



1.75006	371716.2	1.750508	517821.6	1.750139	396354.4
1.800776	372834.3	1.800245	517780.5	1.800917	400546.6
1.850069	373698.8	1.850011	516160.9	1.850752	409265
1.900348	378470.5	1.900666	518933.1	1.900591	419909.9
1.950905	386806.9	1.950401	520900.9	1.95043	432524.3
2.000011	400319.1	2.000137	524423.1	2.000434	449101.7
2.050397	414375.3	2.050242	528189.4	2.050876	458283.9
2.10077	422641.2	2.100361	536420.7	2.100695	465273.5
2.15077	427148.5	2.149987	547854.8	2.150552	469479.5
2.200566	431601.6	2.200495	562556.1	2.200687	472925
2.250474	435286.6	2.250021	577455.3	2.250371	474281.1
2.300159	438560.2	2.300002	591944.9	2.300204	475609.5
2.350334	441239.1	2.35031	606739.8	2.350011	478091
2.40052	441071.5	2.400881	620080.9	2.400783	483547.6
2.450706	444554.7	2.450417	627543.8	2.450589	486271.5
2.50089	448079.9	2.500589	632161.9	2.50048	493526.7
2.550104	451883.3	2.550136	634539.3	2.550225	501401.5
2.600431	457631.7	2.600737	637267.3	2.600143	509964.6
2.650307	461202.8	2.650076	639479.6	2.650753	517937.8
2.700693	466040.2	2.700556	641414.6	2.700257	526334.8
2.750164	469033.4	2.75056	643410.1	2.750754	528408.8
2.80062	473432.2	2.800673	643652.2	2.800292	530813.6
2.850724	477586.1	2.850728	645004.4	2.850613	531986.9
2.900797	484936.5	2.900707	647219.8	2.900249	534553.2
2.950631	489896.5	2.950613	649567	2.950801	537751.1
3.000792	494477	3.000155	651253.7	3.000428	541505.2
3.050447	496094.7	3.050326	653303.3	3.050959	543441.4
3.100497	497698.1	3.100745	656675.5	3.100753	548666.2
3.150446	499640.2	3.150487	659463.3	3.15034	553603.5
3.200235	501431.4	3.200826	663815.5	3.200129	558802.9
3.250269	503644.4	3.25043	667025.7	3.250365	563066.1
3.300371	505210.7	3.300737	669961.3	3.300774	567499.6
3.35033	507883.3	3.350692	676129.9	3.350193	569266.7
3.400078	508662.8	3.400598	683868	3.400466	575500.3
3.450939	510828.5	3.450134	687602.1	3.450737	575880.6
3.500095	512517.6	3.500785	692795.7	3.500822	577962.3
3.550115	515119.9	3.550589	703049.7	3.550958	580007.1
3.600087	518352.5	3.600176	710048.9	3.60046	582071.9
3.650104	521021.2	3.650628	712106.6	3.650854	583303.7
3.700027	523583.3	3.700182	713951.5	3.700251	588403.6
3.750656	527459.5	3.75067	720311.8	3.750474	589834.8

3.800337	529991.4	3.800121	723029.6	3.800721	593506.8
3.850919	533849.9	3.850431	724075.4	3.850118	597465.7
3.900724	536494.3	3.900012	723875.6	3.900445	599643.6
3.950335	538545.5	3.95054	724690.1	3.950888	602143.6
4.000109	541055.9	4.00015	724536.4	4.000251	605514.4
4.050094	542759.9	4.050237	722617.8	4.050393	604487.5
4.100725	544496.7	4.100709	722975.3	4.10057	605156.2
4.150514	545576.6	4.150142	725620.5	4.150743	606570.4
4.200249	546541.6	4.200761	723759.1	4.200257	605673.1
4.250678	547080.6	4.249986	723771.4	4.250162	608112.4
4.300619	548198.2	4.300151	720172.6	4.300584	609829.1
4.350401	548353.5	4.350045	718112.9	4.350088	608316.6
4.400081	549899.4	4.400193	715895.6	4.400594	610836.9
4.450543	551008.3	4.450799	714110.5	4.450148	612556.6
4.50015	551948.9	4.500591	705811.1	4.500532	612069.3
4.550098	554349.7	4.550604	701979.2	4.550833	613642.1
4.600464	555076	4.600198	694992.6	4.600393	613833.1
4.650905	557287.2	4.65044	691233.4	4.650853	611205.8
4.700406	558835.9	4.700626	682689.8	4.70049	611871.1
4.750723	560112.6	4.750472	668700.4	4.750903	610972.4
4.800318	562362.9	4.80084	663505.6	4.800521	608875.1
4.850702	563465.1	4.850379	643936.6	4.850136	607960.9
4.90045	565430.8	4.900366	633618.6	4.900611	601736.4
4.95097	565463.9	4.950121	611902.6	4.9505	601439.4
5.000728	567083.9	5.000382	597645.7	5.000351	602583.8
5.050334	567526.3	5.050726	585688.9	5.050124	593190.1
5.100659	568196.4	5.100154	573843.1	5.100358	589471.8
5.150532	568536.8	5.150336	554623.8	5.15063	592446.8
5.200808	567154	5.200315	551100.4	5.200571	584397.8
5.25024	567024.8	5.250009	539987.6	5.250333	577200.8
5.300867	565618.3	5.300579	528827.6	5.300948	578786
5.350674	564126.9	5.350368	521985.1	5.350822	579006.7
5.400472	561367.9	5.400755	508661.9	5.400658	569099.9
5.450446	558781.6	5.450091	499572.5	5.450675	563008
5.500418	555480	5.500372	484181.3	5.500896	557900.7
5.550586	552118.4	5.550506	475141.1	5.550344	550851
5.600739	546537.4	5.600639	460561.4	5.600113	547014
5.65043	538435.3	5.650773	455812	5.650286	541489.4
5.70021	528445.4	5.699978	442445.3	5.70036	537015.1
5.750506	520154.8	5.750112	439899.3	5.750588	530616.1
5.800437	508971.1	5.800246	431932.4	5.800187	534456.1

5.850707	491752.2	5.850379	429898.5	5.850735	530174.9
5.900394	482379.1	5.900133	425031.9	5.900455	522291.9
5.950306	477873.3	5.95012	428079.6	5.95032	525818.4
6.000058	468253.2	6.000107	428184.2	6.000851	522172.1
6.051007	464056	6.050094	430942.6	6.050359	518737.8
6.100869	456897	6.10008	436507.8	6.100129	520477.7
6.150924	451936.6	6.150067	441362.3	6.150687	514002.8
6.200106	451143.3	6.200045	445145.8	6.200084	509501.8
6.25028	445928.5	6.250005	450797.9	6.250503	512166.3
6.300885	447848.1	6.299966	453405.8	6.300847	507695.7
6.350286	445914.7	6.349926	455928.7	6.35068	507316.7
6.400668	441008.6	6.399887	456235	6.400824	507605.8
6.451049	435309.1	6.449848	456164.3	6.450701	507898.6
6.500384	438956.7	6.499808	456699.5	6.500403	504642.8
6.55061	442394.3	6.550677	455016.1	6.550595	506750.5
6.600809	444496.8	6.600626	454860.5	6.600814	505687
6.65088	445171.4	6.650584	455478	6.650925	504234.7
6.700852	446688.7	6.700519	455764.4	6.700655	504784
6.750438	446191.4	6.750453	455096.6	6.750656	501612.2
6.800365	443599.7	6.800387	454118.1	6.800318	502286.1
6.850155	443013.9	6.850322	452877.9	6.850828	501691.4
6.900388	438478.7	6.900256	449181	6.900393	500260.5
6.950313	442537	6.950191	445656.3	6.950735	500000.4
7.000386	440577.8	7.000125	441495.6	7.000234	500138.5
7.05067	441508.5	7.050059	436295.3	7.050194	499775.8
7.10103	439179.3	7.099994	432368.1	7.100241	497310.3
7.150291	438157.6	7.149947	426883.7	7.150086	497494.9
7.200475	437644.5	7.199907	427005.3	7.200265	496513.5
7.250801	432173.6	7.249868	419613.8	7.250269	493968.3
7.300178	429137.2	7.299829	418370.3	7.300597	491564.7
7.350542	431149	7.34979	412828.7	7.350471	490529.8
7.400882	433096.4	7.39975	411840.8	7.40023	489256.2
7.450172	432719	7.449711	409803.7	7.450211	487927.9
7.500526	435216.9	7.499671	409662.3	7.500652	487308.6
7.550798	434748.8	7.549632	409467.3	7.5504	485482.6
7.60096	439027.5	7.599593	412800.4	7.600245	484389.7
7.651033	441984	7.649553	412938.5	7.650662	481297
7.700434	441332.3	7.700422	416287.7	7.700577	477727.6
7.750799	443811.8	7.75038	421216.5	7.750725	478864.2
7.800198	444483.2	7.80032	427201.5	7.800545	476780.1
7.850523	439860	7.850254	431954.5	7.850082	475228.8

7.900894	446909.1	7.900188	436005.9	7.900239	471638.2
7.950235	448883.9	7.950123	437555.7	7.95006	467139.7
8.000428	446159.3	8.000057	441574.1	8.000534	468156.7
8.050839	448266.8	8.049992	440206.2	8.050273	468549.4
8.101089	447487	8.099926	442802.4	8.10076	468001.3
8.150578	441716.9	8.14986	441631	8.150157	465373.2
8.200316	439039.4	8.199795	441571.6	8.200267	462926
8.25058	435431.9	8.250118	441673.5	8.250849	461566.7
8.300879	437864	8.299804	439969.4	8.300798	457964.6
8.351032	441719.3	8.350041	441898.8	8.350941	456679.1
8.40048	443936.2	8.399933	442242.7	8.400745	450800.1
8.450916	444558.1	8.449756	442169.5	8.450232	447671.8
8.500336	449995.8	8.499634	445448.2	8.500496	447618.8
8.550774	452355.3	8.549566	447517.9	8.550452	446557.8
8.600883	448450	8.599501	448392	8.600345	447847.4
8.650175	445703.3	8.649435	449697.5	8.650994	440749.6
8.700294	447536.7	8.699369	449422.9	8.700679	437178.9
8.750668	445854.6	8.749294	448286.6	8.750038	439076.4
8.801102	444454.5	8.799109	443335.5	8.800916	430939.3
8.85054	444102.8	8.849043	444296.3	8.850585	426485.9
8.900831	440338	8.899609	437409.9	8.900571	423469.2
8.951098	440820.4	8.949539	435204.4	8.950952	428351.5
9.000424	441241.9	8.999429	429388.9	9.000332	425467.7
9.050867	443247.9	9.049363	423934.9	9.050469	428664.6
9.100363	442812.6	9.099298	417172.5	9.100617	424944.8
9.150822	445753.4	9.149204	410536.2	9.150922	413022.8
9.2011	440289.2	9.199139	406215.4	9.200265	409591
9.251005	441086.3	9.249032	397607.4	9.250813	406837.8
9.300285	441573.2	9.298966	393783.8	9.300477	397374.6
9.350477	438367.3	9.348901	392565.1	9.350896	392778.6
9.400176	434661.3	9.398835	382194.2	9.400403	394160.8
9.450392	434287.2	9.44877	383730	9.450056	389150.4
9.500631	432493.5	9.498704	378311.8	9.50035	388423.5
9.550875	432341.6	9.549546	376524.3	9.550226	389867.1
9.601053	432845.4	9.599481	374981.8	9.600794	380212.1
9.650967	425253.3	9.64942	383673.2	9.650826	373288.1
9.700436	422777.3	9.699381	383472.7	9.700266	372109.7
9.750919	419413.8	9.749341	386998.6	9.750119	368237
9.800432	414935.8	9.799302	391008.3	9.80014	365245.6
9.850931	408202.5	9.849262	390884.6	9.850195	359040.4
9.900469	405758.3	9.899223	392035.9	9.900307	356163.2

9.950977	403893.4
10.00013	406974.4

9.949104	396398.3
9.99855	396174.6

9.950062	355703.1
9.999973	352630

CFRP jacketed short column eccentricity 20mm	
Displacement	Force
0	0
0.050994	58161.32
0.100987	58020.17
0.150976	110835.9
0.200958	167756.9
0.250939	170457.7
0.300919	223689
0.350762	292815.9
0.400619	288872.7
0.450281	324333.7
0.500749	380839.9
0.550143	384761.5
0.600589	409335.6
0.650246	455917.8
0.700458	464795.3
0.75014	482951.9
0.800928	507550.9
0.850641	531736.4
0.900273	538756.4
0.950461	559973.1
1.000617	578064.2
1.050886	590065.3
1.100744	598598.4
1.150757	609844
1.200255	623679.8
1.250751	634358.7
1.300478	641799.3
1.350682	649492.7
1.400594	657739.4
1.450778	665108.3
1.500813	674088.1
1.550092	680728.3
1.600065	686740.8
1.650039	691122.9

Steel jacketed short column eccentricity 20mm	
Displacement	Force
0	0
0.050994	56637.72
0.100986	56628.59
0.150976	111533
0.200957	160873.2
0.250935	164548.9
0.300905	221862.1
0.350708	280749.4
0.400031	276796.9
0.450717	317671.3
0.500643	364362.2
0.550161	367951.5
0.600057	396378.1
0.650568	440892.2
0.700315	444922
0.75032	461407.3
0.800018	488324
0.850665	507399.4
0.900089	511631.4
0.950324	531356.6
1.000236	548691.1
1.050701	560166.8
1.100309	566011.2
1.150485	575815.8
1.200873	587610.3
1.250747	597475.8
1.300436	604899.3
1.350223	608910.3
1.400562	614268.1
1.450117	620437.6
1.500745	623632.3
1.550313	627551.1
1.600515	627100.2
1.6503	628210.6

RC jacketed short column eccentricity 20mm	
Displacement	Force
0	0
0.050994	63638.9
0.100986	62384.12
0.150975	171514.7
0.200855	179597.5
0.250179	183893.2
0.300633	302692.9
0.350384	297779
0.400003	300158.7
0.450032	398661.8
0.500184	399076.6
0.550263	403313.2
0.600114	479469
0.650117	482324
0.700435	488300.2
0.750001	545339.5
0.80073	560993.3
0.850302	565983.9
0.900486	599745
0.950311	628825
1.000914	634341.9
1.050895	650591.1
1.100529	671606.6
1.150007	680163.2
1.200389	681130.9
1.250771	693867.8
1.300363	700660.9
1.350808	696493.8
1.40043	691907.1
1.45006	699742.3
1.500005	690747.4
1.550936	683176.1
1.600801	678086.5
1.650478	672818.6

1.700792	694286.3	1.700757	627511.8	1.700523	655231.6
1.750117	699060.3	1.750219	624066.3	1.75058	643408.5
1.800465	704078.1	1.800071	619762.8	1.800633	635236
1.850455	707736.6	1.850884	614657.1	1.850691	625200
1.900535	708290.7	1.900735	609084.4	1.90086	614303.6
1.95009	710335.4	1.950315	599928.6	1.950022	613290.3
2.000757	713451.9	2.000131	590180.3	2.000058	610952.6
2.050031	714046.9	2.050665	579352.4	2.05033	606630.9
2.100632	715443.1	2.100658	567501.5	2.100462	601965.9
2.150374	715419.1	2.150457	558033.6	2.150327	597534.3
2.200694	714724	2.200333	549629.8	2.200271	592500.3
2.250537	714411.3	2.250124	537010.1	2.250173	585176.4
2.300091	709991.1	2.30005	528946.1	2.300161	580264.4
2.350833	706226.8	2.35088	515373.5	2.350294	577323.3
2.400588	700359.9	2.400098	503220.8	2.400699	569626.9
2.450944	696774.8	2.450898	495568.3	2.450052	568770.3
2.500133	689597.4	2.500825	489341.1	2.500214	563207.3
2.550132	680762.6	2.550583	482490.4	2.550491	559059.1
2.600547	676380.8	2.600463	476665.5	2.600535	551139.6
2.650722	671074.2	2.650419	473384	2.65069	552747.2
2.700212	663932.7	2.700226	468368.7	2.700102	543987.7
2.750563	660745.1	2.750075	466098.2	2.750568	535936.5
2.800086	649748.6	2.800076	463436	2.800812	538342.8
2.850626	644676	2.850065	462653.5	2.85051	536379.4
2.900116	640253.6	2.900066	458891	2.900958	522347.2
2.950622	637703.4	2.950037	458246.8	2.950101	521114.3
3.000131	629858.2	3.000038	459486.8	3.000187	520956.5
3.050683	626258.1	3.050029	455180.7	3.050341	505566.4
3.100918	625858	3.100029	457124.3	3.100557	508197.7
3.150457	623186.3	3.150023	456850.5	3.150618	507568.2
3.200828	620862.4	3.200006	457901.9	3.200706	498449.8
3.250058	621143.5	3.250008	455308.9	3.250789	494661.9
3.300502	621496.9	3.300009	457676.3	3.300886	488938.1
3.350021	623489.4	3.350008	456866.5	3.350924	442034.4
3.400491	623278.1	3.399984	457212.4	3.400842	395286.3
3.450732	623229.3	3.449986	455320.2	3.450424	388411.7
3.500218	622161.4	3.499985	456569.8	3.500151	365867
3.550602	623419.5	3.549986	457087.9	3.55025	332641.5
3.600056	623274.4	3.599984	457425.6	3.600344	333414.7
3.650467	623043.8	3.649973	454941.9	3.650238	373587.9
3.7	624969.4	3.700794	457331.8	3.700432	365624.3

3.750354	626483.9	3.750795	456649.3	3.750469	361726.3
3.800778	626793.9	3.800797	458071.6	3.800508	392413.1
3.850066	630239.7	3.849855	457461.4	3.850524	376854.8
3.900406	630046.3	3.899856	458072.6	3.900517	359602.1
3.949992	630779.9	3.949857	458081.5	3.950307	354780.2
4.000517	632154.2	3.999853	458307.8	4.000407	329040.5
4.049918	633239.6	4.050748	457133.6	4.050506	305768
4.100316	634429.2	4.100739	458814.2	4.100462	265902.8
4.150726	635835.9	4.15074	458351.3	4.150019	233514.6
4.199976	637441.8	4.200741	458117.2	4.200633	226248.6
4.250444	638767.3	4.250742	458481	4.250669	207675.2
4.299942	639349.9	4.2998	458879.6	4.300733	201019.8
4.350437	640789	4.350628	460816.3	4.350632	233893.5
4.399971	643039.6	4.40063	460389.5	4.400468	252501.2
4.450373	644028.1	4.450631	461155.6	4.450378	247185.4
4.499852	644711.7	4.50063	460810.3	4.500601	255004.3
4.550345	647358.7	4.550632	460771.9	4.550301	252388.7
4.599769	648504.4	4.600633	461001.3	4.600143	232308.6
4.650169	649722.2	4.650618	461215.9	4.650739	210439.2
4.700574	651526.2	4.700619	461411.3	4.700685	204331.3
4.749995	653137.6	4.75062	461273.3	4.750367	201648.7
4.800456	654414.6	4.800579	463071.3	4.800227	197565
4.849802	654466.4	4.850581	461962.1	4.850471	210904.8
4.90028	656938.2	4.900582	463463.5	4.900188	226530.3
4.949721	658936.3	4.950583	462219.3	4.950076	226456.4
5.000087	659725.6	5.000544	462820.7	5.000326	226220.1
5.050408	661808.3	5.050431	464181.9	5.050669	230311.9
5.099809	664308.7	5.100433	464440.3	5.100148	217145.6
5.14992	665117.8	5.150434	464958.2	5.150321	204974.3
5.200392	665149.3	5.200436	463999.6	5.200466	201195
5.249928	667760.4	5.250437	465869.7	5.250098	206653.8
5.299948	668700.7	5.300438	464166.2	5.300165	203139.4
5.350287	669521.1	5.350386	465506.7	5.350856	201266.9
5.400631	671181.8	5.400361	465778.9	5.400727	216378.3
5.450048	672425.3	5.450353	467783.5	5.450686	215362.6
5.500489	672245.9	5.500354	465794.4	5.500226	205758.9
5.549889	675524	5.550251	467579.3	5.55037	204360
5.600191	675361	5.600157	467125.4	5.600425	197081.7
5.650703	676765.9	5.650165	467014.2	5.650645	192649.8
5.7001	677626.2	5.700167	467321.9	5.700743	186687.1
5.750366	677798.1	5.750127	468578.8	5.750074	189097.4

5.799799	678613.6	5.800141	468807.5	5.800424	201010.5
5.85027	677624.6	5.850149	469126.3	5.85008	205364
5.900678	678850.4	5.900155	469154.3	5.900738	206082.3
5.950027	677951	5.950169	469491.4	5.950088	208943.8
6.000394	677346.3	6.00018	469021.7	6.000837	204206
6.050651	676505.8	6.050189	469326.7	6.050611	193518.7
6.100039	676480.9	6.100066	468717.5	6.100134	179008.2
6.150453	675059.3	6.150005	469860.5	6.150391	180265
6.200294	673598.3	6.200016	469957.3	6.19991	186268.7
6.25017	671940.2	6.250004	469316.8	6.250102	184909.2
6.300279	669336.6	6.300005	469653.9	6.300001	192583.9
6.349826	668667.5	6.349983	468182	6.349983	205262.5
6.400683	668011.6	6.399973	468294.3	6.400077	201940.4
6.450104	667132.8	6.449926	467879.6	6.45013	193245.3
6.500667	664444.2	6.499918	466312.3	6.500762	186446.1
6.550507	665435.6	6.549909	466193.2	6.55048	184340.9
6.6003	667006.9	6.599908	466375.3	6.600226	186126.5
6.650776	667578.4	6.6499	466639.2	6.650775	183254.4
6.700662	667918.5	6.699876	466280.8	6.700194	184569.1
6.750649	668117.9	6.74987	465989.2	6.750347	195053.6
6.800445	668898.7	6.799875	465623.7	6.800485	194492.8
6.850421	669077	6.849872	465903.3	6.850573	188206.1
6.900415	671683.5	6.899881	463202.6	6.90044	185864.1
6.950486	670722.1	6.949869	462104.9	6.950747	185291.7
7.000378	672094.3	6.999882	461353.4	7.000344	183701.4
7.050485	672786.4	7.049896	460390	7.05089	183322.7
7.10065	672232.9	7.099911	459962.4	7.100868	183962.6
7.150596	673806.3	7.149924	460357.6	7.150804	186005.7
7.200494	672446.4	7.199927	460576.6	7.200338	184163.2
7.250578	673738.3	7.249934	459676.5	7.250276	183076.8
7.300593	672380.4	7.299949	458838.3	7.300143	180471.9
7.350512	670994.2	7.349962	458418.9	7.350211	181428.2
7.400334	670183.4	7.399961	457372.3	7.400638	181946.3
7.450474	669204.2	7.449975	457814.3	7.450279	183756.3
7.500467	668642.5	7.49999	458917.5	7.500297	188054.4
7.55043	665554.9	7.550004	458907.3	7.550723	185164.9
7.600355	664017.9	7.600018	458368.8	7.600917	182507
7.650302	661056.3	7.650032	458251.7	7.650002	179144.3
7.700254	661387.5	7.700046	457707.6	7.700423	178882.6
7.750422	659930.9	7.749984	457213.9	7.750271	178280
7.800369	659789.3	7.799998	458927.8	7.800105	180399.1



7.850474	659337.1	7.850012	458542.7	7.850152	185759.6
7.900202	658736.8	7.900026	458178.3	7.900747	181994.6
7.950378	656817.6	7.95004	457027.5	7.950478	178591
8.000409	657706.4	8.000054	457095.8	8.00061	175942.9
8.050394	658519.4	8.050065	457383.4	8.050791	176500
8.100447	659240.7	8.100079	458275	8.100755	179200.8
8.150606	659871.7	8.150093	456572.9	8.150157	178831.7
8.200416	660648.4	8.2001	457565.8	8.200635	186287
8.250312	661724	8.250106	457677.8	8.250712	186584.7
8.300231	663293.9	8.300119	455990.8	8.300548	183570.5
8.350323	663731.4	8.350134	458088.6	8.350503	176268.3
8.400201	664951.8	8.400148	457965.8	8.400693	172219.3
8.450168	665230.1	8.450158	458565.6	8.450316	170401.3
8.500206	665416.5	8.500172	457775.9	8.500398	173902.9
8.550125	666098.1	8.550186	457795.1	8.550027	173568
8.60004	666828.3	8.600201	458574.2	8.600182	180772.5
8.650104	667713.6	8.650214	457435.2	8.650281	183559.3
8.699963	667474	8.700228	457533.1	8.700603	181626.4
8.750811	667941.7	8.750242	456832.5	8.750572	178691.1
8.799966	666292.4	8.800191	455480.9	8.800859	175747.9
8.850058	665277.2	8.850205	456316.3	8.850821	174852
8.900179	663714.6	8.900219	456431.6	8.90007	173549.5
8.950305	662355.1	8.950207	456385.1	8.950451	175048.8
9.000383	661206.5	9.00022	455576.4	9.000809	178065.1
9.050414	660402.1	9.050235	455177.6	9.050582	172228.7
9.100608	659042.3	9.100248	455803.9	9.100069	179085.6
9.150681	656804.1	9.150199	455803.6	9.150803	179055.8
9.200857	654524.8	9.200212	455001.4	9.200758	172876.2
9.250862	654363.6	9.250227	454321.3	9.250123	172010.6
9.300041	654343.5	9.30024	453394.2	9.30052	176175.1
9.350183	654059.8	9.350253	453936.3	9.350972	175563.9
9.400326	654815.3	9.400267	454186.2	9.400211	173131.5
9.45043	654011.5	9.450281	453235.7	9.450129	172613.9
9.500526	654084.9	9.500287	452441.6	9.500953	175118.7
9.550373	655106.6	9.550293	451937	9.550442	172516.2
9.600327	655534.8	9.600307	451974.4	9.600883	174526
9.650208	654850.8	9.650321	450338.4	9.650598	180122.3
9.70035	656463	9.700335	450628	9.700976	179216.8
9.750414	656919.2	9.750348	450943.3	9.750202	175039.9
9.800321	657447.1	9.800223	450694	9.800333	176192.5
9.850335	657362.5	9.850238	450399.4	9.850761	171812.9

9.900381	658035.7
9.950823	657962.1
9.999991	657878.8

9.900251	450561.6
9.950266	450998.5
9.999886	450828.7

9.900864	166914.5
9.950605	164122.6
10.00007	169188.8

## APPENDIX-D

Inter Storey displacement and Drift versus Time

Table D. 1: Inter Storey displacement in the Y-direction versus Time.

First-floor displacement bare frame		Third-floor displacement bare frame		Sixth-floor displacement bare frame	
displacement	time	Displacement	time	Displacement	time
0	0	0	0	0	0
0.109209	0.260356	0.109209	0.539845	0.109209	0.265102
0.337662	2.038937	0.337662	1.937867	0.337662	0.917667
0.687662	9.200632	0.687662	10.43798	0.687662	10.87338
1.037662	7.69817	1.037662	6.933176	1.037662	7.039536
1.318756	6.798332	1.318756	6.903047	1.318756	6.939003
1.521658	-4.21366	1.521658	1.066247	1.521658	7.74756
1.608357	-11.8405	1.608357	-8.49508	1.608357	-7.29915
1.671551	-5.25756	1.671551	-17.6061	1.671551	-20.6558
1.760606	-3.44267	1.760606	-12.1335	1.760606	-22.1242
1.838864	-4.56855	1.838864	-10.1409	1.838864	-2.34851
1.918156	4.642878	1.918156	15.06985	1.918156	4.093139
1.969187	4.173144	1.969187	6.162071	1.969187	25.7567
2.028799	7.997228	2.028799	19.18997	2.028799	18.16674
2.115464	-5.1445	2.115464	8.143912	2.115464	29.26605
2.18326	5.421201	2.18326	1.53365	2.18326	-6.97159
2.2183	15.92435	2.2183	3.354968	2.2183	-23.2414
2.286384	5.978225	2.286384	-8.12242	2.286384	-12.2962
2.345506	19.06186	2.345506	1.892002	2.345506	-2.33513
2.411061	13.07126	2.411061	19.44284	2.411061	25.11087
2.465458	7.753321	2.465458	21.98901	2.465458	41.38547
2.543911	36.69989	2.543911	42.27024	2.543911	41.37541
2.620096	39.9482	2.620096	37.78932	2.620096	59.24836
2.664094	11.5077	2.664094	39.73031	2.664094	64.27508
2.734442	23.79541	2.734442	25.79092	2.734442	50.0225
2.775977	15.50582	2.775977	34.1786	2.775977	19.04274
2.855309	4.59304	2.855309	10.40957	2.855309	19.52267
2.893638	-1.3853	2.893638	1.780136	2.893638	14.37464
2.950725	-3.26969	2.950725	0.335439	2.950725	3.949635
3.020791	2.33726	3.020791	-4.49499	3.020791	3.937688
3.084255	-9.02593	3.084255	-8.83328	3.084255	-9.68154
3.161462	-2.82071	3.161462	2.553296	3.161462	0.027952
3.207933	-14.1089	3.207933	-1.89776	3.207933	17.72466
3.259751	-8.88565	3.259751	-0.36261	3.259751	21.26622

3.294079	-3.7958
3.354141	10.90984
3.420213	4.809409
3.480352	-1.85496
3.5	4.447128

3.294079	12.17935
3.354141	20.94416
3.420213	3.712331
3.480352	3.76518
3.5	11.19529

3.294079	12.22362
3.354141	11.30895
3.420213	33.03421
3.480352	22.48466
3.5	33.59373

First-floor displacement RC jacketed frame	
displacement	time
0	0
0.109209	0.113817
0.340905	1.457942
0.690905	9.10372
0.910298	10.43419
1.107876	7.025423
1.400851	5.282048
1.5656	-6.00574
1.604233	-11.0726
1.691113	-3.06619
1.727255	-4.18301
1.791589	-4.0746
1.852951	-6.24929
1.90428	1.049853
1.973611	-2.32642
2.043894	8.497451
2.121071	-11.3649
2.158761	-3.04042
2.21344	18.06226
2.273088	21.43195
2.335974	18.567
2.391531	15.51328
2.457102	5.058462
2.54876	26.14616
2.611319	30.18603
2.675454	6.111617
2.759344	23.42356
2.853505	16.09518
2.910788	-6.9968
2.969232	-11.8165
3.037667	-6.14294
3.109843	6.544484

Third-floor displacement RC jacketed frame	
Displacement	time
0	0
0.109209	0.04465
0.340905	0.999135
0.690905	9.499256
0.910298	11.06665
1.107876	6.763834
1.400851	4.921942
1.5656	-3.27272
1.604233	-6.09938
1.691113	-8.24493
1.727255	-5.46433
1.791589	-9.92557
1.852951	-6.93569
1.90428	2.534141
1.973611	-3.50785
2.043894	6.852103
2.121071	-3.33178
2.158761	-1.03323
2.21344	12.03157
2.273088	26.04041
2.335974	18.36261
2.391531	21.53763
2.457102	11.37961
2.54876	25.68613
2.611319	22.96052
2.675454	13.55296
2.759344	24.4436
2.853505	8.847796
2.910788	-0.7265
2.969232	-17.7927
3.037667	-15.9285
3.109843	2.828592

Sixth-floor displacement RC jacketed frame	
Displacement	time
0	0
0.109209	0.010841
0.340905	-0.02977
0.690905	10.24172
0.910298	12.22607
1.107876	5.94528
1.400851	3.665626
1.5656	6.686046
1.604233	0.432748
1.691113	-17.4953
1.727255	-26.011
1.791589	-14.4083
1.852951	-2.28752
1.90428	-2.92132
1.973611	1.417068
2.043894	-9.1981
2.121071	17.2639
2.158761	13.70578
2.21344	-1.48342
2.273088	6.970083
2.335974	35.11464
2.391531	21.90031
2.457102	25.01699
2.54876	-1.27529
2.611319	3.124099
2.675454	38.49859
2.759344	29.74224
2.853505	12.1356
2.910788	-7.42098
2.969232	-10.2552
3.037667	-14.3482
3.109843	-20.8483

3.177863	-4.65458
3.236767	-17.9453
3.297239	-9.88916
3.353865	12.47126
3.400829	3.451907
3.464593	-5.21022
3.5	6.24396

3.177863	2.074761
3.236767	-18.3798
3.297239	-4.46886
3.353865	-0.75421
3.400829	1.471753
3.464593	-1.24044
3.5	7.44788

3.177863	-1.7693
3.236767	14.99031
3.297239	-17.5418
3.353865	-29.2649
3.400829	-14.1907
3.464593	14.54422
3.5	19.81582

First-floor displacement CFRP jacketed frame	
displacement	time
0	0
0.091328	0.116662
0.236993	0.488747
0.535799	5.859246
0.736684	9.312397
1.058174	7.741483
1.381924	5.923681
1.556926	-7.05077
1.589675	-12.1384
1.662464	-4.46497
1.720641	-0.4431
1.772672	0.112081
1.836084	-3.99197
1.900053	1.060306
1.966807	-0.65742
2.020123	5.269608
2.098098	-11.4645
2.17625	10.67889
2.209314	25.50212
2.255977	19.38474
2.325239	23.86955
2.391599	24.67879
2.453625	5.177457
2.514872	40.12209
2.570957	33.73399
2.628441	25.99181
2.68033	21.77712
2.735448	32.69075
2.789321	18.88918
2.850299	19.34205

Third-floor displacement CFRP jacketed frame	
Displacement	time
0	0
0.091328	0.020861
0.236993	-0.0198
0.535799	5.351659
0.736684	10.24917
1.058174	7.737811
1.381924	4.992557
1.556926	-2.49741
1.589675	-4.34442
1.662464	-13.3089
1.720641	-5.92353
1.772672	-7.8486
1.836084	-9.56548
1.900053	3.690891
1.966807	-3.29307
2.020123	4.905882
2.098098	-4.43729
2.17625	10.39147
2.209314	18.07664
2.255977	22.18117
2.325239	20.66858
2.391599	33.76312
2.453625	17.33568
2.514872	17.59843
2.570957	37.52055
2.628441	26.49008
2.68033	32.51734
2.735448	33.64301
2.789321	24.65822
2.850299	24.08277

Sixth-floor displacement CFRP jacketed frame	
Displacement	time
0	0
0.091328	-0.0333
0.236993	-0.05698
0.535799	4.119686
0.736684	11.6043
1.058174	7.749412
1.381924	3.46187
1.556926	6.617899
1.589675	1.743802
1.662464	-11.7292
1.720641	-26.7389
1.772672	-16.6086
1.836084	-2.52816
1.900053	-4.55685
1.966807	3.276532
2.020123	-8.13641
2.098098	20.08324
2.17625	-0.06955
2.209314	0.586781
2.255977	8.709917
2.325239	47.43727
2.391599	22.95011
2.453625	45.84299
2.514872	9.960486
2.570957	-12.3748
2.628441	45.91076
2.68033	53.47588
2.735448	34.83841
2.789321	35.80247
2.850299	21.95927

2.894529	16.74517
2.949319	2.140851
3.014076	-2.24643
3.072836	16.77913
3.131622	22.23607
3.184475	-3.36782
3.235999	-0.52481
3.288888	6.375851
3.345021	21.45728
3.396756	22.44216
3.426689	22.15346
3.49496	11.36595
3.5	14.2039

2.894529	23.00607
2.949319	-6.72786
3.014076	-7.96091
3.072836	17.40085
3.131622	4.361704
3.184475	3.409287
3.235999	14.74943
3.288888	12.7
3.345021	15.12467
3.396756	24.50529
3.426689	16.47071
3.49496	11.73067
3.5	15.90942

2.894529	-1.40154
2.949319	-7.0019
3.014076	-2.18194
3.072836	-18.3333
3.131622	-0.46593
3.184475	14.67108
3.235999	21.58612
3.288888	17.4232
3.345021	0.777288
3.396756	-5.62133
3.426689	10.2391
3.49496	47.50751
3.5	49.77428

First-floor displacement steel jacketed frame	
displacement	time
0	0
0.091328	0.126843
0.226727	0.394257
0.387359	2.333546
0.595734	7.171952
0.735568	9.250128
0.902432	9.648953
1.060681	7.771092
1.223125	5.873166
1.360384	5.772735
1.549255	-6.93051
1.61857	-12.2504
1.682662	-1.50142
1.757253	-2.45564
1.811363	-6.51589
1.877234	1.102416
1.91688	0.02037
1.964713	-1.5682
2.018444	6.934961
2.066995	-0.63195
2.111169	-7.66527
2.152545	6.080555
2.200936	19.73863
2.216414	16.90847

Third-floor displacement steel jacketed frame	
Displacement	time
0	0
0.091328	0.03681
0.226727	0.052323
0.387359	1.680745
0.595734	6.933475
0.735568	10.22872
0.902432	10.77717
1.060681	7.945552
1.223125	4.374033
1.360384	4.708175
1.549255	-1.50587
1.61857	-9.01114
1.682662	-8.52979
1.757253	-6.00889
1.811363	-6.71682
1.877234	-4.91826
1.91688	3.338032
1.964713	-2.9431
2.018444	3.112849
2.066995	1.764505
2.111169	-8.33818
2.152545	-0.8671
2.200936	12.93129
2.216414	17.51004

Sixth-floor displacement steel jacketed frame	
Displacement	time
0	0
0.091328	-0.00391
0.226727	0.275046
0.387359	0.858806
0.595734	6.950866
0.735568	11.75577
0.902432	12.34541
1.060681	7.906113
1.223125	2.814145
1.360384	2.7475
1.549255	8.282774
1.61857	-1.50022
1.682662	-18.5805
1.757253	-15.9073
1.811363	-7.53336
1.877234	-5.22202
1.91688	-7.8613
1.964713	3.871331
2.018444	-7.37414
2.066995	-6.76434
2.111169	14.3955
2.152545	9.285229
2.200936	-10.275
2.216414	-0.75801

2.230503	28.83033
2.252091	11.30319
2.294099	12.80914
2.321757	19.30554
2.353955	20.61412
2.383256	20.97983
2.426893	14.75081
2.455973	0.706573
2.491848	13.59433
2.531259	31.87163
2.563126	39.56858
2.57149	28.41312
2.584423	29.94939
2.613434	22.55548
2.6264	21.22321
2.640492	16.57588
2.674448	17.63181
2.697537	16.66371
2.717387	19.1742
2.746217	20.4246
2.77245	16.71346
2.811522	17.79288
2.831386	20.2815
2.862864	16.00961
2.898577	12.99537
2.938693	-9.59201
2.981447	-10.1639
3.00448	-12.3987
3.038587	0.468334
3.065269	3.387744
3.092733	8.770495
3.125758	-4.0476
3.161862	-16.0984
3.189304	-18.1905
3.212946	-10.8715
3.227819	-13.3188
3.259859	-10.1488
3.285148	-13.6373
3.323075	-0.36849
3.339531	-0.21846
3.363124	-1.08966

2.230503	15.14575
2.252091	20.52617
2.294099	9.583658
2.321757	13.86281
2.353955	28.18821
2.383256	28.5541
2.426893	11.93573
2.455973	15.23462
2.491848	12.27236
2.531259	23.5347
2.563126	27.28988
2.57149	32.17084
2.584423	31.82642
2.613434	19.92326
2.6264	21.2511
2.640492	18.43159
2.674448	18.96594
2.697537	27.12055
2.717387	26.11262
2.746217	28.33529
2.77245	24.52859
2.811522	15.67104
2.831386	13.97227
2.862864	21.60642
2.898577	14.86101
2.938693	-3.09855
2.981447	-21.431
3.00448	-14.838
3.038587	-3.79255
3.065269	0.144103
3.092733	-0.79746
3.125758	-12.3995
3.161862	-12.1415
3.189304	-15.7338
3.212946	-12.9836
3.227819	-10.5107
3.259859	-13.3316
3.285148	-16.702
3.323075	-20.2721
3.339531	-11.8707
3.363124	-6.28839

2.230503	-3.92504
2.252091	4.560543
2.294099	28.82821
2.321757	36.85385
2.353955	16.71853
2.383256	16.15427
2.426893	38.94535
2.455973	39.15099
2.491848	27.04974
2.531259	5.113356
2.563126	-15.326
2.57149	-4.22492
2.584423	9.37846
2.613434	29.88373
2.6264	38.85653
2.640492	33.72577
2.674448	41.06396
2.697537	46.67334
2.717387	34.96545
2.746217	37.64803
2.77245	32.1585
2.811522	38.28819
2.831386	29.16775
2.862864	5.556182
2.898577	6.565532
2.938693	9.559269
2.981447	18.15186
3.00448	2.460707
3.038587	-16.2893
3.065269	-36.27
3.092733	-20.2802
3.125758	-10.1927
3.161862	7.49284
3.189304	2.284783
3.212946	-4.12107
3.227819	-3.1852
3.259859	-12.1751
3.285148	-11.3504
3.323075	-8.72162
3.339531	-23.983
3.363124	-37.5518

3.397396	-0.581
3.431883	-15.2836
3.444466	-23.3542
3.454402	-16.7404
3.477293	-13.4001
3.5	-5.13393

3.397396	-4.40402
3.431883	-12.5246
3.444466	-13.4559
3.454402	-23.1031
3.477293	-26.3002
3.5	-10.4948

3.397396	-20.5932
3.431883	-8.82589
3.444466	4.679186
3.454402	4.165524
3.477293	12.67529
3.5	8.976274

Table D.2: Inter Storey Drift in the Y-direction versus Time.

Story drift one bare frame	
Displacement	time
0	0
0.109209	0.072208
0.337662	0.049694
0.687662	0.660162
1.037662	-0.19506
1.318756	0.275293
1.521658	1.571508
1.608357	1.319284
1.671551	-4.82753
1.760606	-6.23542
1.838864	0.937401
1.918156	9.320167
1.969187	-1.70742
2.028799	8.955493
2.115464	-6.9773
2.18326	-11.9956
2.2183	-1.34892
2.286384	-13.8386
2.345506	7.293449
2.411061	-0.49685
2.465458	-3.86198
2.543911	-0.79578
2.620096	20.57796
2.664094	1.169173
2.734442	14.13264
2.775977	3.852836
2.855309	-6.48333
2.893638	-6.16673
2.950725	7.556098

Story drift three bare frame	
Displacement	time
0	0
0.109209	0.13946
0.337662	-0.09104
0.687662	0.566537
1.037662	-0.34504
1.318756	0.021802
1.521658	3.163899
1.608357	2.75154
1.671551	-7.24182
1.760606	-8.26905
1.838864	-4.7504
1.918156	8.013273
1.969187	3.710572
2.028799	4.131729
2.115464	14.17867
2.18326	-9.66114
2.2183	-12.4287
2.286384	-1.41782
2.345506	-10.2162
2.411061	1.557278
2.465458	15.00824
2.543911	-5.27308
2.620096	-3.15814
2.664094	17.71433
2.734442	-3.59024
2.775977	5.263439
2.855309	1.068658
2.893638	5.183577
2.950725	3.900383

Story drift six bare frame	
Displacement	time
0	0
0.109209	-0.1124
0.337662	-0.34676
0.687662	0.001261
1.037662	0.119681
1.318756	-0.03484
1.521658	1.373262
1.608357	-0.47161
1.671551	-0.46435
1.760606	0.110773
1.838864	-0.12139
1.918156	-0.28173
1.969187	8.244795
2.028799	-3.64007
2.115464	12.7072
2.18326	-2.07756
2.2183	-6.98364
2.286384	1.174784
2.345506	-3.51975
2.411061	3.471647
2.465458	5.029758
2.543911	5.144676
2.620096	9.162109
2.664094	3.68132
2.734442	2.97797
2.775977	-10.1452
2.855309	5.817383
2.893638	-1.2441
2.950725	-7.09172



3.020791	7.180329
3.084255	-9.61505
3.161462	7.263011
3.207933	-2.59511
3.259751	9.154528
3.294079	-3.34447
3.354141	10.16769
3.420213	8.999294
3.480352	8.650008
3.5	-4.91993

3.020791	3.99096
3.084255	-0.66452
3.161462	1.365487
3.207933	11.66099
3.259751	8.103226
3.294079	10.26299
3.354141	7.718442
3.420213	0.40125
3.480352	5.848745
3.5	4.747648

3.020791	7.361004
3.084255	-8.00593
3.161462	-2.06424
3.207933	1.973255
3.259751	2.788689
3.294079	-0.80044
3.354141	4.12667
3.420213	12.22904
3.480352	-2.62444
3.5	11.38236

Story drift one RC jacketed frame	
Displacement	time
0	0
0.109209	-0.01886
0.340905	-0.18931
0.690905	0.245692
0.910298	0.656782
1.107876	-0.04414
1.400851	-0.03619
1.5656	3.882069
1.604233	0.506914
1.691113	1.673188
1.727255	-3.40165
1.791589	6.238745
1.852951	-9.89024
1.90428	-2.28831
1.973611	-2.09192
2.043894	8.105191
2.121071	0.601355
2.158761	-0.85449
2.21344	5.221598
2.273088	-1.57285
2.335974	1.143463
2.391531	8.992027
2.457102	-4.02543
2.54876	-8.2529
2.611319	9.636484
2.675454	0.211742
2.759344	9.71967

Story drift three RC jacketed frame	
Displacement	time
0	0
0.109209	-0.06917
0.340905	-0.45881
0.690905	0.395536
0.910298	0.632453
1.107876	-0.26159
1.400851	-0.36011
1.5656	2.733012
1.604233	4.973251
1.691113	-5.17874
1.727255	-1.28132
1.791589	-5.85097
1.852951	-0.68641
1.90428	1.484288
1.973611	-1.18143
2.043894	-1.64535
2.121071	8.033099
2.158761	2.00719
2.21344	-6.03069
2.273088	4.608456
2.335974	-0.20439
2.391531	6.024347
2.457102	6.321144
2.54876	-0.46003
2.611319	-7.22551
2.675454	7.441339
2.759344	1.020041

Story drift six RC jacketed frame	
Displacement	time
0	0
0.109209	0.02632
0.340905	-0.26468
0.690905	0.135802
0.910298	0.289876
1.107876	-0.24256
1.400851	-0.42114
1.5656	2.855576
1.604233	1.160192
1.691113	-0.82961
1.727255	-8.26352
1.791589	-4.60806
1.852951	1.209279
1.90428	0.182904
1.973611	4.111247
2.043894	-9.19044
2.121071	11.48133
2.158761	5.044582
2.21344	-9.34843
2.273088	-5.3705
2.335974	11.60839
2.391531	-6.23398
2.457102	4.820267
2.54876	-1.78563
2.611319	-13.1872
2.675454	-0.7473
2.759344	4.740961

2.853505	4.836892
2.910788	8.143951
2.969232	4.54803
3.037667	9.188545
3.109843	10.08037
3.177863	7.95758
3.236767	4.373119
3.297239	-4.75072
3.353865	18.1964
3.400829	9.172994
3.464593	7.466454
3.5	1.005703

2.853505	-7.24739
2.910788	6.270306
2.969232	-5.97621
3.037667	-9.78561
3.109843	-3.71589
3.177863	6.72934
3.236767	-0.43444
3.297239	5.420294
3.353865	-13.2255
3.400829	-1.98015
3.464593	3.969785
3.5	1.20392

2.853505	7.568738
2.910788	-7.14156
2.969232	-1.77864
3.037667	-4.67936
3.109843	-6.67747
3.177863	5.765736
3.236767	13.2684
3.297239	0.05666
3.353865	-5.00319
3.400829	-2.80091
3.464593	9.68282
3.5	5.900041

Story drift one CFRP jacketed frame	
Displacement	time
0	0
0.091328	-0.04513
0.236993	-0.17594
0.535799	-0.11358
0.736684	0.368644
1.058174	0.068724
1.381924	-0.21512
1.556926	1.351901
1.589675	0.414848
1.662464	-1.65913
1.720641	-5.37462
1.772672	-3.1837
1.836084	2.418832
1.900053	-1.14266
1.966807	-5.62057
2.020123	-0.52397
2.098098	-5.70735
2.17625	3.812533
2.209314	10.13125
2.255977	8.750332
2.325239	-5.06176
2.391599	16.93252
2.453625	-5.46813
2.514872	5.208874
2.570957	11.37902

Story drift three CFRP jacketed frame	
Displacement	time
0	0
0.091328	-0.04015
0.236993	-0.2484
0.535799	-0.30082
0.736684	0.500837
1.058174	-0.03193
1.381924	-0.49184
1.556926	3.002413
1.589675	4.174266
1.662464	-4.7114
1.720641	-1.5625
1.772672	-0.8774
1.836084	-4.79789
1.900053	3.302229
1.966807	-2.16282
2.020123	-1.81222
2.098098	-0.92047
2.17625	-1.78338
2.209314	-2.87048
2.255977	0.015652
2.325239	-2.50528
2.391599	3.937162
2.453625	5.113679
2.514872	-4.28395
2.570957	-4.5387

Story drift six CFRP jacketed frame	
Displacement	time
0	0
0.091328	-0.02678
0.236993	0.061974
0.535799	-0.38943
0.736684	0.383851
1.058174	0.016074
1.381924	-0.44261
1.556926	2.665483
1.589675	2.247318
1.662464	0.922365
1.720641	-8.66089
1.772672	-4.24785
1.836084	0.245723
1.900053	-2.72051
1.966807	3.988951
2.020123	-4.01758
2.098098	15.9114
2.17625	-2.7458
2.209314	-6.01783
2.255977	-14.1294
2.325239	17.90759
2.391599	-11.3102
2.453625	15.16082
2.514872	-1.63462
2.570957	-24.7207

2.628441	8.66069
2.68033	7.350302
2.735448	17.96943
2.789321	12.5655
2.850299	2.341448
2.894529	4.777962
2.949319	5.514396
3.014076	-6.4496
3.072836	15.20436
3.131622	12.5958
3.184475	13.19554
3.235999	15.49809
3.288888	4.338206
3.345021	17.01741
3.396756	23.70514
3.426689	30.56646
3.49496	5.402513
3.5	3.176157

2.628441	-4.71631
2.68033	12.03021
2.735448	8.167368
2.789321	4.372358
2.850299	1.855762
2.894529	2.970863
2.949319	7.815763
3.014076	4.589247
3.072836	-1.10484
3.131622	-0.06346
3.184475	11.84178
3.235999	2.248124
3.288888	4.868988
3.345021	2.75966
3.396756	-0.00547
3.426689	-0.31741
3.49496	0.598348
3.5	2.27599

2.628441	11.66694
2.68033	8.771099
2.735448	-10.497
2.789321	-4.54142
2.850299	6.481164
2.894529	-3.80639
2.949319	-13.1528
3.014076	-2.15883
3.072836	-11.6541
3.131622	-10.5146
3.184475	-9.47609
3.235999	4.430918
3.288888	6.883205
3.345021	-2.16209
3.396756	-14.7716
3.426689	-11.0664
3.49496	15.21974
3.5	20.81833

Story drift one steel jacketed frame	
Displacement	time
0	0
0.091328	-0.03667
0.226727	-0.15778
0.387359	-0.30199
0.595734	-0.14315
0.735568	0.330871
0.902432	0.485076
1.060681	0.102903
1.223125	-0.4729
1.360384	-0.46727
1.549255	0.416552
1.61857	0.442686
1.682662	-1.48805
1.757253	-3.84216
1.811363	-7.58708
1.877234	4.54683
1.91688	4.980506
1.964713	-5.83787
2.018444	-0.35166

Story drift three steel jacketed frame	
Displacement	time
0	0
0.091328	-0.03811
0.226727	-0.14015
0.387359	-0.32178
0.595734	-0.098
0.735568	0.525999
0.902432	0.596434
1.060681	0.077423
1.223125	-0.79916
1.360384	-0.5938
1.549255	2.987238
1.61857	1.782989
1.682662	-3.31154
1.757253	-4.06768
1.811363	3.075381
1.877234	-5.1255
1.91688	-0.43294
1.964713	-1.49416
2.018444	-0.64436

Story drift six steel jacketed frame	
Displacement	time
0	0
0.091328	-0.01251
0.226727	0.133737
0.387359	-0.22929
0.595734	0.040602
0.735568	0.413354
0.902432	0.42341
1.060681	-0.0633
1.223125	-0.34492
1.360384	-0.60107
1.549255	3.346064
1.61857	2.109224
1.682662	-1.7828
1.757253	1.209789
1.811363	1.227323
1.877234	-3.36578
1.91688	-5.544
1.964713	3.214937
2.018444	-5.9744

2.066995	-2.11895
2.111169	-12.3991
2.152545	-7.66952
2.200936	1.268074
2.216414	1.169238
2.230503	4.463634
2.252091	2.215262
2.294099	-11.9706
2.321757	-10.8465
2.353955	9.051404
2.383256	13.99838
2.426893	7.013576
2.455973	-4.7364
2.491848	-4.34486
2.531259	7.966898
2.563126	13.50295
2.57149	8.749956
2.584423	-5.35829
2.613434	0.626213
2.6264	0.956629
2.640492	2.273026
2.674448	6.970854
2.697537	6.823763
2.717387	3.256603
2.746217	15.0022
2.77245	1.480952
2.811522	-4.37949
2.831386	9.649915
2.862864	6.443597
2.898577	7.441701
2.938693	-1.83476
2.981447	2.220452
3.00448	-11.9364
3.038587	4.180786
3.065269	5.427841
3.092733	8.613094
3.125758	-7.09878
3.161862	-5.06554
3.189304	-2.16429
3.212946	1.982677
3.227819	7.413556

2.066995	6.893575
2.111169	8.956482
2.152545	2.505453
2.200936	-0.6071
2.216414	-8.43552
2.230503	-3.60406
2.252091	-3.21387
2.294099	-2.27008
2.321757	-0.27164
2.353955	5.408562
2.383256	5.206326
2.426893	-1.54575
2.455973	8.755456
2.491848	-0.47899
2.531259	-10.1627
2.563126	-5.19447
2.57149	-6.26521
2.584423	1.667774
2.613434	-5.73479
2.6264	2.166798
2.640492	5.942604
2.674448	6.582531
2.697537	4.51277
2.717387	6.531612
2.746217	1.640875
2.77245	9.839797
2.811522	3.396297
2.831386	-2.05033
2.862864	4.461723
2.898577	0.904208
2.938693	8.166866
2.981447	-1.88819
3.00448	2.265451
3.038587	-7.72094
3.065269	-1.72383
3.092733	-5.40992
3.125758	0.963052
3.161862	1.085649
3.189304	0.849069
3.212946	2.412561
3.227819	-1.63523

2.066995	-10.1411
2.111169	7.781427
2.152545	7.96159
2.200936	-10.5361
2.216414	1.232816
2.230503	-9.76155
2.252091	-2.81558
2.294099	8.376972
2.321757	15.62984
2.353955	-7.42517
2.383256	-11.3883
2.426893	6.772236
2.455973	13.95802
2.491848	9.157505
2.531259	0.372313
2.563126	-27.4973
2.57149	-13.1026
2.584423	0.736572
2.613434	6.356606
2.6264	13.70621
2.640492	-0.28804
2.674448	1.992535
2.697537	12.35536
2.717387	-2.55737
2.746217	4.657928
2.77245	-2.87593
2.811522	10.64139
2.831386	3.620255
2.862864	-9.15201
2.898577	1.347097
2.938693	2.695228
2.981447	18.31424
3.00448	7.38458
3.038587	1.425585
3.065269	-19.4119
3.092733	-2.29759
3.125758	-2.27963
3.161862	14.2876
3.189304	6.155648
3.212946	1.185688
3.227819	5.049787

3.259859	5.186339
3.285148	-7.86848
3.323075	3.172897
3.339531	-4.76247
3.363124	-0.76583
3.397396	9.194671
3.431883	7.168021
3.444466	-6.60981
3.454402	-15.9532
3.477293	-1.35116
3.5	-13.7212

3.259859	2.237325
3.285148	0.54038
3.323075	-15.1463
3.339531	-1.82045
3.363124	-2.80839
3.397396	-10.3952
3.431883	-2.15792
3.444466	4.183568
3.454402	4.350464
3.477293	-7.83708
3.5	3.524121

3.259859	-2.25089
3.285148	1.459566
3.323075	10.7591
3.339531	-1.18939
3.363124	-15.3199
3.397396	4.80101
3.431883	2.563876
3.444466	15.02092
3.454402	7.771792
3.477293	13.33677
3.5	15.2124